

## Welcome to the Hunter Family

Congratulations on your new Hunter sailing yacht. We have engineered and constructed your Hunter to be as fine a cruiser as any afloat. In order to get the best performance and most enjoyment from your boat you should be familiar with its various elements and functions. Please take time to study this manual and its recommendations for trouble-free sailing pleasure.

We stand behind the quality of your Hunter with a warranty which you should also review. **To insure your warranty is valid, please fill out the attached card and send it to us within ten days of the purchase date.** Section 15 of the Federal Boat Safety Act requires first owners to be registered. The warranty data should also be recorded in the space below for your own reference.

You also need to fill out and mail the warranty cards on your diesel auxiliary, battery, stove, head, electric water pump and other accessories. These are enclosed in the manufacturers' manuals which are included in your owner's pouch

(Hull Identification Number is on outside of transom, starboard side, upper corner. This number must be given in all necessary communications.)

### HUNTER OWNER INFORMATION CARD

DATE DELIVERED TO OWNER \_\_\_\_\_

Hull # \_\_\_\_\_

Owner \_\_\_\_\_

Street \_\_\_\_\_

City and State \_\_\_\_\_ Zip \_\_\_\_\_

Model \_\_\_\_\_ Size \_\_\_\_\_ Hull # \_\_\_\_\_

Engine Model \_\_\_\_\_ Serial # \_\_\_\_\_

Name of Boat \_\_\_\_\_ Propeller Size \_\_\_\_\_

Dealer \_\_\_\_\_

Street \_\_\_\_\_

City and State \_\_\_\_\_ Zip \_\_\_\_\_

Dealer's Signature \_\_\_\_\_

Owner's Signature \_\_\_\_\_

A copy of Chapman's **Piloting, Seamanship and Small Boat Handling** is provided with your Hunter as part of the standard equipment. Any questions regarding the meanings of terminology used in this manual may be referenced in your Chapman's.

## **Limited Warranty**

HUNTER MARINE warrants to the first use purchaser for a period of twelve (12) months from the date of sale any part manufactured by HUNTER to be free of defects caused by faulty workmanship or materials under normal use and service.

During this period HUNTER will repair or replace any part judged to be defective by HUNTER free of charge at its plant or at the option of HUNTER, by an authorized HUNTER dealer. Transportation costs are the responsibility of the first use purchaser. The labor cost reimbursement will be based on a labor allowance schedule established by HUNTER and where not applicable, on a reasonable number of hours as determined by HUNTER. All repairs and replacements must be approved in advance by an authorized HUNTER representative.

This warranty does not cover:

- (1) Paint, window glass, gel coat, upholstery damage, plastic finishes, engines, engine parts, propellers, shafts, controls, instruments and equipment not manufactured by HUNTER. Any warranty made by the manufacturer of such items will be, if possible, passed on to the first purchaser.
- (2) Boats or parts which have been altered or subjected to negligence or misuse.
- (3) Commercially used boats.

THIS WARRANTY IS EXPRESSLY IN LIEU OF ANY AND ALL OTHER REMEDIES AND EXPRESSED WARRANTIES. ANY IMPLIED WARRANTIES, INCLUDING THE WARRANTIES OF MERCHANTABILITY AND FITNESS ARE LIMITED TO THE DURATION OF THIS LIMITED WARRANTY. Some states do not allow limitations on how long an implied warranty lasts, so that the above limitation may not apply to you.

ANY CONSEQUENTIAL DAMAGES WHICH MAY BE INCURRED ARE EXCLUDED AND THE LIABILITY OF HUNTER AND THE PURCHASER'S REMEDY SHALL BE LIMITED TO REPAIR OR REPLACEMENT OF ANY PART OR PARTY JUDGED DEFECTIVE BY HUNTER. Some states do not allow the exclusion or limitation of incidental or consequential damages, so the above limitation or exclusion may not apply to you.

The purchaser acknowledges that no other representations were made to him with respect to the quality and function of the boat.

This warranty gives you specific legal rights and you may have other rights which vary from state to state.

This warranty shall not be effective unless the HUNTER warranty card and predelivery service record are completed and returned to HUNTER within ten (10) days after the date of sale to the first use purchaser.



## TUNING THE B&R RIGGING

### NOMENCLATURE DESIGNATION

upper-upper.....	D3*
lower upper.....	V2
lower intermediate.....	V1
lower.....	D1
upper intermediate.....	D2*
lower diamond.....	d1
upper diamond.....	d2

\*D2 and D3 are cut to a fixed length (no turnbuckles).

Initial tuning is best accomplished before the mast is stepped.

Support the mast, forward side down, about 1/4 of its length from the end and at its center. Once the mast is supported, make certain that it has no bow in any direction. Attach a small string from the masthead, in line with the sail track groove, to the base of the mast, stretching it as tight as possible. Check to make sure it is a constant distance from the mast along the entire length.

You are now ready to "tune in" the desired mast bend, which is 1% of the mast height above the boom (.01 x mast height above boom). On a 50' mast, this would be .5 feet at the mid point of the mast.

Using the rigging diagram, locate d1 and d2. Before tuning, make sure the turnbuckles are adjusted back with equal thread showing. Carefully counting turns, adjust d1 port, d1 starboard, d2 port and d2 starboard evenly until the desired bend is induced. This is checked by measuring from the string down to the mast at the center of the mast.

It is important to make sure the mast is straight athwartships at this time.

You are now ready to step the mast.

Step the mast with all shrouds loosely attached.

Adjust the forestay and backstay to obtain the desired mast rake. The mast should be vertical or raked aft. The more rake, the greater the weather helm. The

forestay and backstay should have a reasonable amount of tension on them.

Adjust V2 (port and starboard) evenly until they are tight. You should finish with approximately equal amounts of thread showing on each turnbuckle.

Using the jib halyard, check the mast for athwartship plumb. Pull the halyard out to the side of the boat and below the shear. Repeat the procedure on the opposite side. If you find a big difference (more than 1/2") adjust turnbuckles an equal amount in opposite directions until the mast is straight.

Adjust V1 (port and starboard), using the above procedure.

Repeat for D1 (port and starboard).

Your mast should now have the original "pre-bend" and be straight athwartship.

Check the mast tuning by sailing in medium winds (10-12 knots). Sail on both tacks, sighting up the luff groove to check athwartship straightness. Shrouds should not be loose on the leeward side. When mast tuning is complete, install cotter pins in all turnbuckles and tape over sharp edges of the cotter pins with chafe tape.

# Hunter

## B & R RIGGING

**D3, Upper Upper:**  
Runs from Upper Tang to  
Upper Spreader Tip

**Upper Spreaders**

**V2, Lower Upper:**  
Runs from Upper Spreader  
Tip, thru Lower Spreader  
Tip to Chainplate on Deck

**D2, Upper Intermediate:**  
Runs from Tang below  
Upper Spreaders to Lower  
Spreader Tips

**d2, Upper Diamond:**  
Runs from Upper Spreader  
Tip to Tang above Lower  
Spreader

**Lower Spreaders**

**V2, Lower Upper Cont.**

**V1, Lower Intermediate:**  
Runs from Lower Spreader  
Tip to Chainplate on Deck

**d1, Lower Diamond:**  
Runs from Lower  
Spreader Tip to Tang  
above Bottom End of  
Mast Extrusion

**D1, Lower:**  
Runs from Tang below  
Lower Spreader to  
Chainplate on Deck

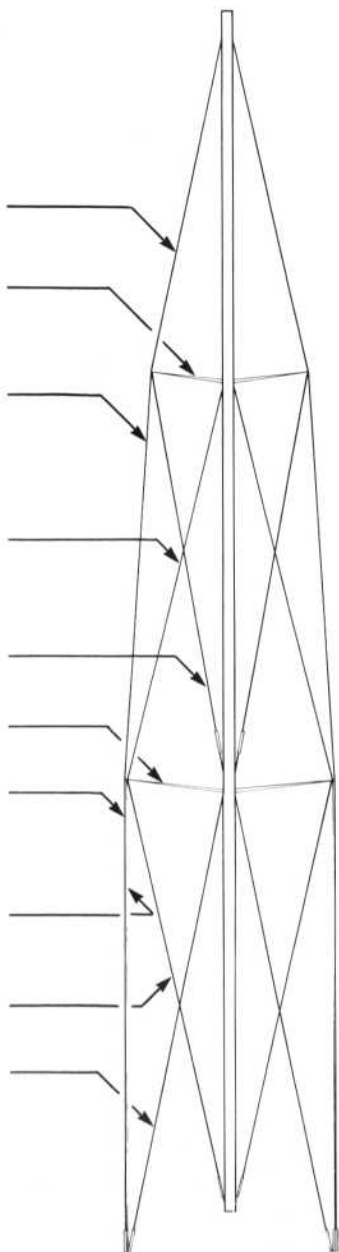



## TUNING THE RIGGING:

### MAST TUNING INSTRUCTIONS:

#### **Attach stays and shrouds.**

After raising your mast, attach the headstay, backstay, upper shrouds and lower shrouds. Set the headstay turnbuckle at 1/2 open and then tighten backstay turnbuckle to medium tension.

To center mast athwartships, start with only slight tension on the upper and lower shrouds. Check to see if the mast is centered in the boat by measuring from the masthead to the chainplates with a steel tape measure hoisted completely up the main halyard. Adjust the upper shroud until the measurements port and starboard are exactly the same. Now the spar is plumb athwartships, tension both uppers equally, counting turnbuckle revolutions as you go. Tighten uppers until you have approximately 1" of "prebend" fore and aft in the mast. This is achieved because the swept spreaders will push the middle part of the mast forward as you increase tension of the uppers.

Now tighten the lower shrouds evenly making sure the mast remains straight athwartship. Sight up the luff groove to assure this straightness. Lowers should end up almost as tight as the uppers. Tighten backstay to a taut position. Perhaps 8-10 turns past your original tension.

Check the mast tuning by sailing in medium winds (10-12 knots). Sometimes fine tuning of the upper and lower shrouds is necessary when the spar is loaded in sailing conditions. Sail on both tacks, sighting up the luff groove to check athwartship straightness. Both upper and lower

shrouds should not be loose on the leeward side.

When mast tuning is complete, install cotter pins in all turnbuckles and tape over sharp edges of the cotter pins with chafe tape.

# Hunter

RIGGING DIAGRAM

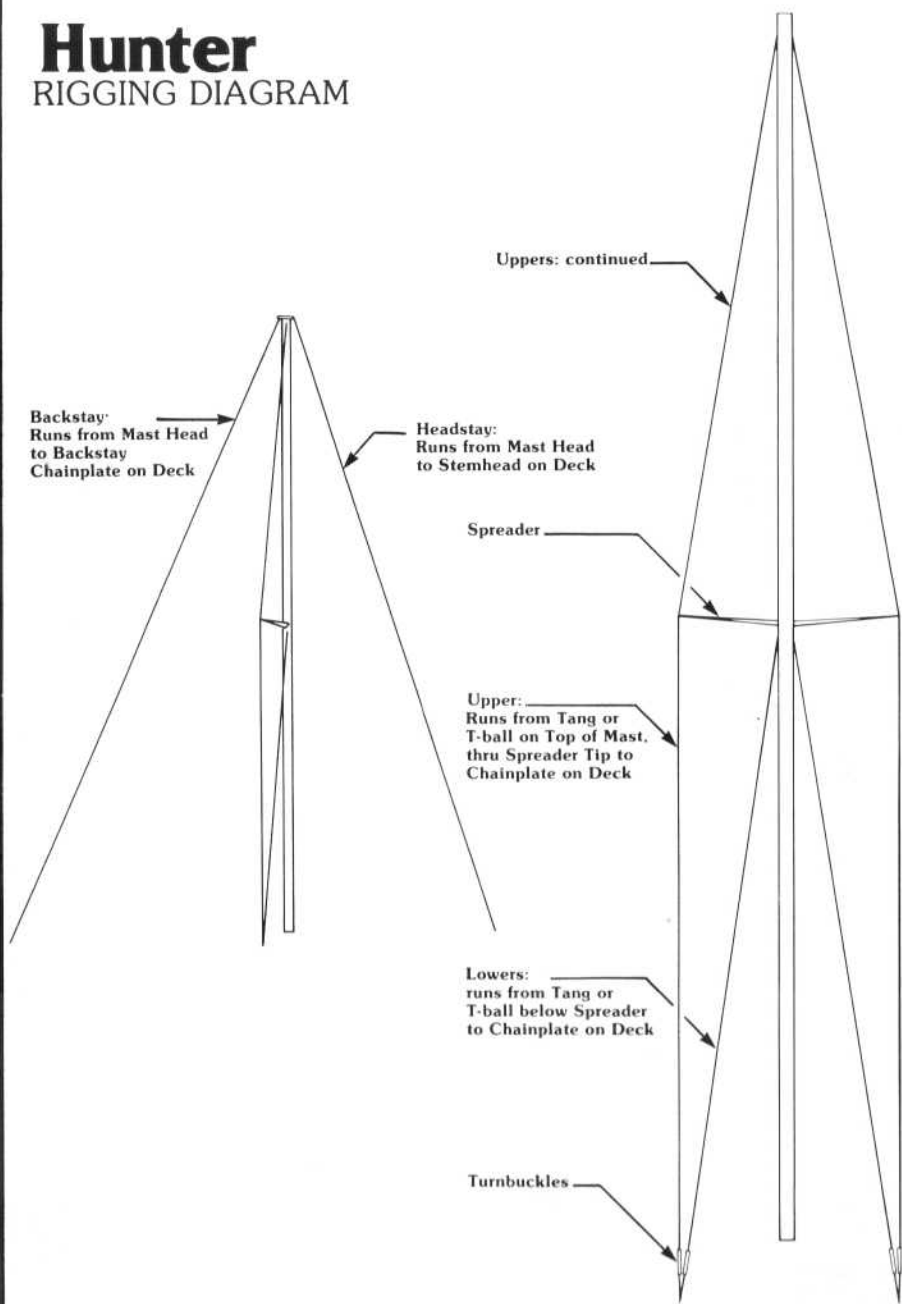



## CARE OF RUNNING RIGGING

To protect your running rigging (sheets, halyards) from damage, wash with cold water (and a mild detergent, if necessary), especially after exposure to salt water. Rinse thoroughly and coil. Hang the tail ends of halyards off the deck to promote drying. Sheets should also be hung to dry.

Inspect all lines periodically for fraying and other damage. Lines showing substantial wear should be replaced.

## CARE OF STANDING RIGGING

The stays and shrouds on your Hunter are highly durable stainless steel to insure years of reliable service. To protect your standing rigging, keep it clean, and, whenever possible, rinse thoroughly with fresh water. Check occasionally for "fishhooks," strands of wire that have broken and curled outward. These can snag sails and inflict painful cuts in bare hands. Broken strands indicate the wire is deteriorating and should be replaced.

Also inspect turnbuckles regularly and replace any missing cotter pins. Occasional lubricating improves both the life and the function to turnbuckles.

## ENGINE ALIGNMENT

The engine should be aligned by experienced marine service personnel. Final alignment should be done after launching, with all normal gear aboard. A description of the procedure follows.

The coupling flanges must come together evenly at all points, a feeler gauge is used to check the gap. If adjustment is necessary, the engine is tilted up or down, and/or side to side until the flanges meet equally. Severe vibration will result from misalignment and can cause strut bearing and shaft damage.

Alignment should be checked again after several weeks of use.

## SHAFT LOG

The stuffing box is held to the shaft log tube by a rubber tube, secured by hose clamps. The clamps should be tight and no water should leak from this location.

A slight drip from the stuffing box at the shaft exit is necessary (4 drops a minute).

To adjust, loosen lock nut, tighten gland nut 1/4 turn, retighten lock nut. If excessive water flow persists after adjustment, replace the packing and then adjust as above.





## DIESEL ENGINE

An engine owners manual is supplied with your boat and should be read thoroughly. The manual contains technical specifications, running instructions and maintenance schedule on lubricants and fluids. For long engine life, follow routine maintenance schedules.

You should check engine oil, transmission fluid, and coolant levels. Water, rust, scale and dirt will cause serious damage to the injectors on diesel engines. You should check your filters frequently and change when necessary.

If you start your engine, run it a minimum of 15 minutes to bring it up to operating temperature. This insures that any condensation is evaporated. Your engine should "run-out", at 3/4 throttle, at least once a month to clean out carbon build up and moisture.

### STARTING:

1. Visually check engine compartment to see that the throttle linkage, shifting controls, electrical connections and fuel lines are properly secured.
2. BEFORE EACH START check oil in engine and transmission.
3. Insure that engine shut-off cable is properly secured and operating.
4. Place the shift lever (Fig. 1a) in the neutral position.

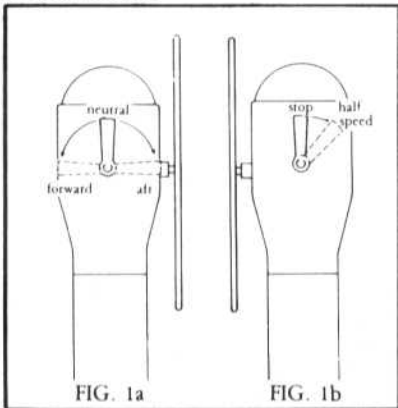

5. Move the throttle or "fuel" lever (Fig. 1b) forward to approximately the half speed position.

6. Insert the starter key and turn to the "ON" position.

7. Press the starter button and hold until engine starts, then release. The buzzer and/or light should then go off.

8. Back the throttle off to an idle position (700-800 rpm) allow cold engine to warm up a minimum of 5 minutes.

9. Check to see that the lube oil pressure warning light and the charge lamp go off.

If any of the warning lamps do not go off above 1000 rpm, the engine is malfunctioning and should be stopped immediately. Consult your nearest engine dealer.

**NOTE:** To stop engine at any time, pull "fuel" lever all the way aft (Fig. 1b). Before stopping, however, it is a good idea to idle the engine in neutral for about 5 minutes, then race it in the full throttle position for a moment, then return to idle and stop the engine.

**CAUTION:** DO NOT TURN SAFETY MAIN SWITCH TO "OFF" WHILE ENGINE IS RUNNING. THIS CAN SERIOUSLY DAMAGE THE ALTERNATOR.

### MOTING:

When engine is warm, you may move the "shift" lever either forward to go ahead or aft to move in reverse (Fig. 1a).

**CAUTION:** your rigging will conduct electricity. Always check for overhead high tension wires before proceeding. Once clear, you may increase your speed in a reasonable and safe manner as desired.

**IMPORTANT:** do not shift from forward to reverse or back without first lowering engine rpm.

# HUNTER



## ELECTRICAL SYSTEM

Your Hunter is fitted with an electrical system designed for both AC (AC not available on the 25.5 and smaller) and DC. While in port, you can operate any tool, appliance or other device designed to function on regular house current (120V) simply by plugging your dockside power cord into a convenient outlet on shore, and turning your AC main breaker on.

(DO NOT ALLOW YOUR DOCKSIDE POWER CORD TO COME IN CONTACT WITH THE WATER. NEVER OPERATE ANY AC POWER TOOL OR OTHER ELECTRICAL EQUIPMENT WHILE YOU OR THE DEVICE ARE IN CONTACT WITH THE WATER.)

When leaving port, disconnect the dockside power cord and turn the main DC breaker on. This allows you to use the ship's lights and other equipment designed to operate on direct current. Keep in mind that your DC power source is a 12-volt battery and, just as with your automobile, it must be charged regularly by operating the engine. Unless a state of charge is maintained, there may not be enough power to operate the starter motor. Dangerous situations can result if the engine cannot be started when needed.

Make a regular visual check of battery(ies) to insure proper water level and to inspect terminals for signs of corrosion. If your boat sits for long periods without use, it is often a good idea to remove the battery(ies) and attach them to a trickle charger to keep them fully charged and ready for use.

## REEFING THE MAINSAIL

Your Hunter is equipped with an easy-to-use jiffy reefing system. To reef the main:

1. Ease the main sheet (boom vang if installed) — make sure topping lift is secured in position.

2. Lower main halyard so that tack reef cringle (1) can be placed on gooseneck reef hook (2). Retension main halyard when hooked in place.
3. Clew reef line (3) must now be tensioned so that clew reef cringle is brought down snugly against boom.

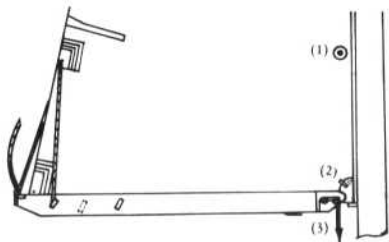

4. Re-adjust mainsheet and boom vang.
  5. The reefed folds of cloth can be rolled up and secured with short lines through the reef points and around the folds and boom.
- IMPORTANT:** be sure to untie these first when shaking out the reef.
6. To unreef, reverse the process.

## OPERATION OF THE WATER SYSTEM

The water heater operates either on 120 volts AC or when the engine is running. To obtain hot water from the engine it must run a minimum of one half hour.

**CAUTION:** do not turn the water heater on until you are sure the tank is filled with water. To do so will destroy the heating element, which would not be covered by the warranty.

Pressure water pumps are the demand type. Once the circuit breaker switch is on, opening the faucet will produce water flow.

**NOTE:** intermittent operation of the fresh water pump while all faucets are

# HUNTER

closed usually indicates a leak somewhere in the lines. Trace the lines to locate the leak and correct.

## STOVE OPERATION

Follow the operating instructions supplied with the unit installed with your boat.

## TOILET

**IMPORTANT:** When not in use, lever must be left in the dry position to prevent flooding.

Before using, place the lever in the wet position and pump slowly to partly fill and wet the inside of the bowl. Return to dry position.

After using: return the lever to the wet position for flushing and pump until the bowl is thoroughly cleaned. Continue with several more full strokes to flush discharge lines. Return lever to the dry position and pump slowly until bowl is empty.

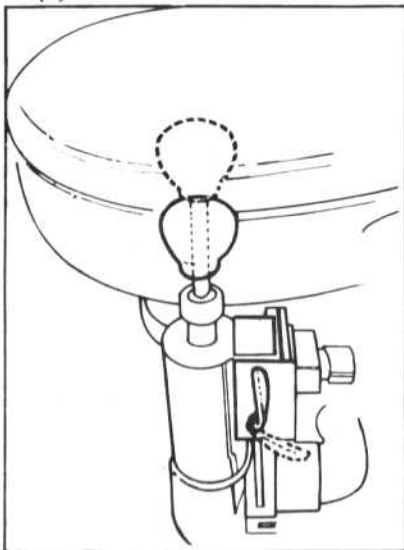

## CLEANING OF FIBERGLASS SURFACES

Fiberglass surfaces should be cleaned regularly. Normal accumulations of surface dirt can be removed simply by occasional rinsings with water. If your boat is operated in saltwater, more frequent rinsing will be required. To remove stubborn dirt, grease or oil, use a mild detergent and a soft brush. Rinse with clean fresh water.

It is also a good idea to wax the fiberglass once or twice a year to maintain a deep, glossy appearance. Your local marine supply should be able to supply an appropriate wax.

## FIBERGLASS REPAIRS

Your Hunter dealer can supply you with the proper gel coat to be used in repairing any hairline cracks or chips.

1. Using a mild detergent solution, clean repair area completely of wax, dirt or oil and dry completely.

2. To patch "spiderweb" or hairline cracks, begin by widening the crack so that it will hold putty. This is most easily done with an electric drill or router equipped with a V-shaped grinding bit. Also, cut a quarter inch or so beyond the end of each crack to relieve any stress.

3. Brush away all dust from the crack.

4. Mix gel coat with filler powder to form a creamy consistency, mix more than enough patching compound to do the job and stir to a smooth blend. Temperatures should be in the 60's or above, or a heat lamp should be used

5. Using a putty knife, work the mixture firmly into the crack to eliminate air bubbles. Leave an excess of about 1/16th of an inch above the surface of the crack to allow for shrinkage.



6. Since gel coat will only dry fully in the absence of air, cover the area with a sheet of cellophane or plastic food wrap and tape edges to make the covering airtight.

7. When the putty has reached a tacky consistency, peel back the seal and carefully slice away the excess filler that protrudes above the surface.

8. Replace seal and allow putty to harden. Once hardened, remove seal and sand flush using 320 wet or dry sandpaper and follow with 600 wet sandpaper. Buff with fine buffing compound to desired luster and finish by applying a coat of wax.

## SAIL CARE AND STORAGE

Your Hunter comes with Dacron mainsail and 110% genoa jib. To extend the life of your sails and maintain their best performance:

1. Never use them in wind ranges that exceed their capabilities.

2. Never let them luff for extended periods of time.

3. Rinse your sails in fresh water whenever possible if you sail in saltwater. Tub wash them every few seasons to keep them bright and attractive. **DO NOT MACHINE WASH.** Use a mild detergent in warm water, and **REMOVE ALL DETERGENTS COMPLETELY WITH A THOROUGH RINSING.**

For oil and grease stains, use commercial cleaning solvents. Should a yellow stain develop, bleach with oxalic acid and rinse thoroughly. Rust stains should be soaked in a warm solution of two parts hydrochloric acid per 100 parts water, rinsing thoroughly.

After rinsing your sails, spread them and allow to dry thoroughly before bagging. This is a good time to inspect them for minor damage. First spread sail on flat surface, then fold in a smooth accordion

pleat from the foot to the head. Next roll the folded sail from the clew to the tack and slide carefully into bag.

At the end of each season, it is good practice to have your local sailmaker inspect your sails for signs of wear and tear.

## TEAK CARE

Teak wood is an extremely durable wood with a high oil content. To maintain that durable quality it should be given a coat of teak oil once a year or more in northern climates and twice a year or more in tropical climates.

Teak can be allowed to weather out, as seen on many boats, but this will eventually lead to cracking and splitting.

If you wish to maintain your teak with varnish, resin or urethane; a sealer should be applied after cleaning and sanding. Complete finish procedures can be obtained from your marine finish products manufacturer or supplier.

## SERVICING OF PUMPS

All pumps should be checked frequently to insure proper operation. **THIS IS AN ESPECIALLY IMPORTANT REGULAR MAINTENANCE ITEM SINCE FUNCTIONING OF A PUMP COULD SAVE YOUR VESSEL FROM SERIOUS DAMAGE AT SOME FUTURE TIME.**

Inspect all hoses for chafing and dry rot. See that hose clamps are tight.

Check to see that pump impeller area is clean and free from obstructions.

Inspect electrical wiring for corrosion.

Make sure float switch moves freely and is making an electrical connection.

# HUNTER



## WINCH MAINTENANCE

Follow the maintenance instructions prescribed by the winch manufacturer.

## GENERAL MAINTENANCE OF HARDWARE

Check all fittings regularly to be sure screws are tight.

Occasionally lubricate all moving parts on such fittings as blocks, turnbuckles and cam cleats, as well as the locking pins of snatch blocks, track slides, spinnaker poles, etc.

Inspect chocks, cleats and fairleads for roughness and smooth with finegrained emery paper if necessary.

Also, replace any missing or damaged cotter pins in turnbuckles and shackles, and either tape them or use protective covers manufactured for that purpose.

## STORING YOUR BOAT FOR WINTER

**IMPORTANT:** Winter storage should be on the cradle supplied with the boat. The cradle should be blocked level and square to prevent twisting the boat. Damage to your boat, including engine misalignment caused by twisting, is not covered by the warranty.

## SAILS

Sails and synthetic lines should be washed and dried thoroughly. Sails should be properly folded and stowed in a dry, well ventilated place. Many sailboat owners send their sails back to the sail manufacturer at the end of each season. The sailmaker will check the stitching and sailcloth for wear and store the sails until the start of the next season.

## CUSHIONS

Cushions should be removed and stored at home if possible. If not, prop them vertically to promote airflow around each cushion.

## HATCHES

Hatches and floorboards should be left open a crack to provide ventilation for the whole boat. However, it is prudent to loosely cover any open hatches with a tarp or plastic sheeting.

## WATER SYSTEM

Open a faucet and allow the pump to empty the tank. Then add approximately 2 gallons of *non-toxic* anti-freeze solution to the tank and repeat the pumping out process.

A second method is to disconnect the hoses at the pump, allowing them to drain. Find the lowest point in the system and disconnect the fitting. Open all faucets to allow the lines to drain. If possible, use a short piece of hose on the faucet to blow through the lines to clear all water.

## HOT WATER HEATER

Open valve and drain fully. Leave valve open during lay-up-time.

## TOILET AND HOLDING TANK

Drain and flush toilet. Using automotive anti-freeze (ethyleneglycol) in a 50/50 mixture with water, pump through toilet and into holding tank.

## ENGINE

1. Drain the cooling water completely out of the engine and flush the line thoroughly with fresh water. Don't use high pressure through the line.

2. Remove the fuel completely from all fuel lines.

3. Disconnect the main battery cables from the battery terminals.

# HUNTER



4. To prevent corrosion inside the cylinders, pour a little lubricating oil into the suction pipe while turning the engine. Enough oil to reach the intake/exhaust valves is sufficient.

5. Put the piston at top dead center of compression stroke so that the intake/exhaust valves are completely closed.

6. Apply a thin anti-corrosion treatment to the plating and exposed painted surfaces.

7. The engine should be in a well-ventilated area, and protected from any kind of dampness.

8. Put a dust cover over the engine.

9. Check your operation manual for engine diagram and for **MANUFACTURERS RECOMMENDED WINTERIZING PROCEDURES.**

# Hunter 28.5

## SPECIFICATIONS

L. O. A.	28' 5"	8.66m.
L. W. L.	23' 9"	7.24m.
Beam	10' 6"	3.20m.
Displacement:		
Deep	7000 lbs.	3175.1 kg.
Shoal	7100 lbs.	3220.5 kg.
Draft:		
Deep	5' 2"	1.57m.
Shoal	4' 0"	1.21m.
Ballast:		
Deep	3000 lbs.	1360.7 kg.
Shoal	3100 lbs.	1406.1 kg.
Mast height		
From Waterline	41' 3"	12.57m.
Headroom	6' 2"	1.87m.
Sail area	398 sq.ft.	36.97m.
E (Mainsail foot)	10' 10"	3.30m.
J (Foretriangle base)	12' 1"	3.68m.
P (Mainsail luff)	31' 9"	9.68m.
I (Foretriangle ht.)	37' 4"	11.38m.

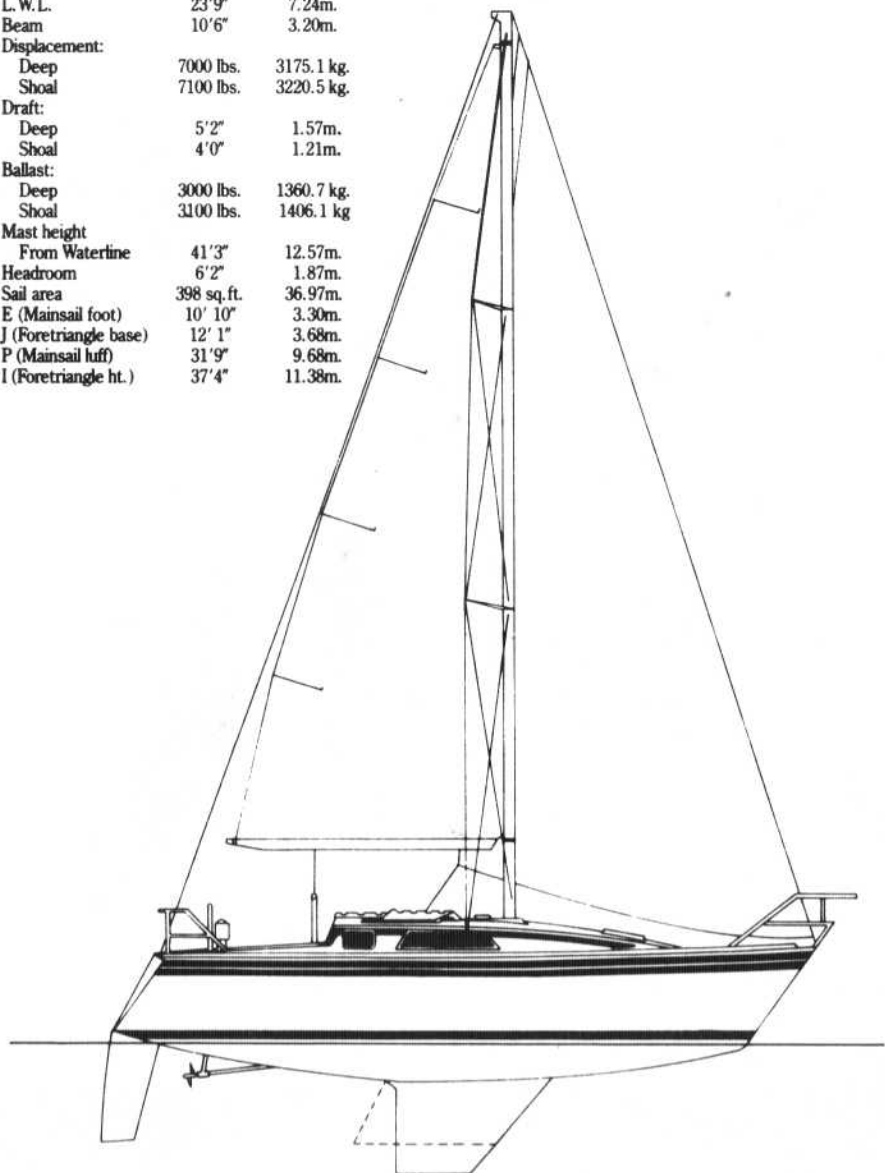

# Hunter 28.5

SAIL PLAN & SPECIFICATIONS *continued*

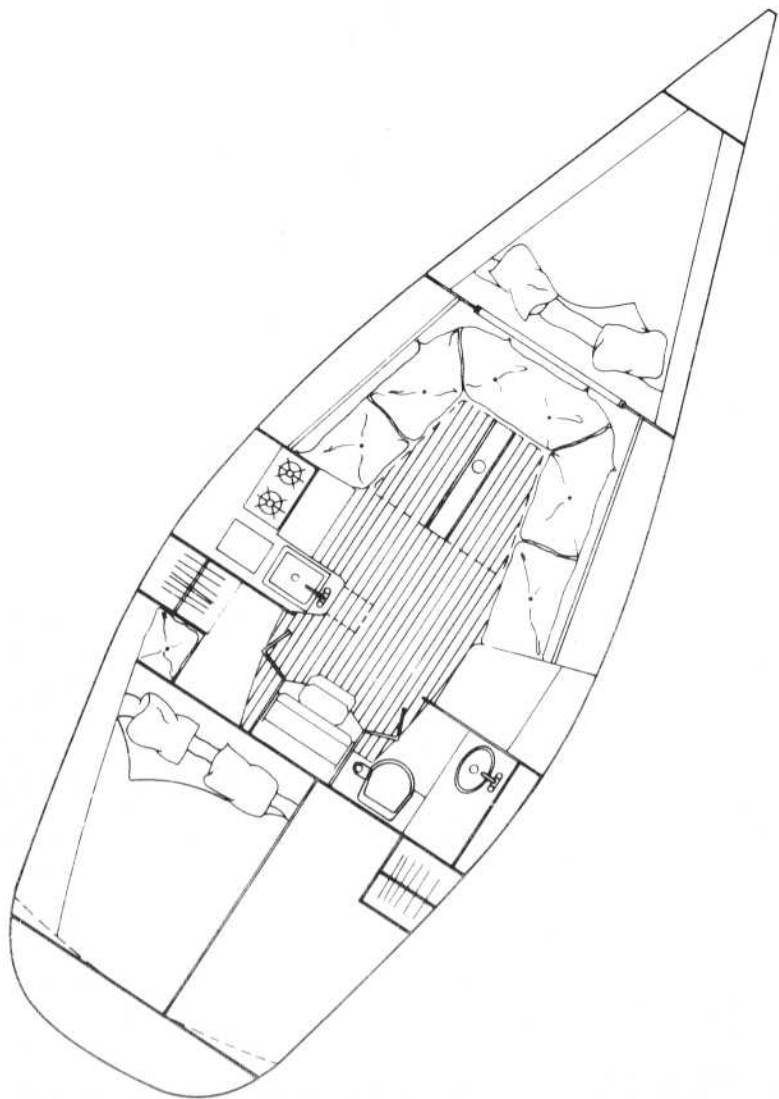



# Hunter 28.5

ELECTRICAL DIAGRAM AC/DC

- LEGEND:**
1. SWITCH PANEL
  2. 72 AMP BATTERY
  3. AUTOMATIC FLOAT SWITCH
  4. BILGE PUMP (Electric)
  5. MAST COMPRESSION POST
  6. PRESSURIZED WATER PUMP (Electric)
  7. WATER HEATER

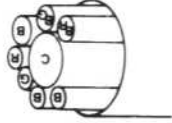
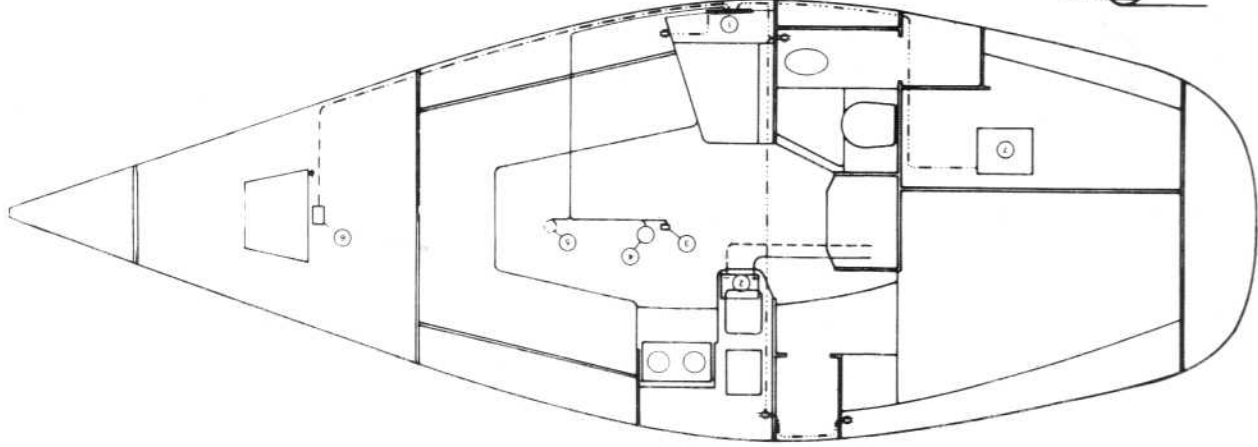

**NOTE:**  
CHAINPLATES AND MAST ARE GROUNDED TO  
FWD KEEL EAR BOLTS WITH #8 GAUGE BLACK WIRE.

**SYMBOLS:**

-----	4 GA. RED BATTERY CABLE
-----	4 GA. BLACK BATTERY CABLE
-----	14/3 BOAT CABLE (110 V)
-----	WIRE HARNESS "B"
-----	10 GA. WIRE BLACK/RED FOR PRESSURIZED WTR. PUMP

-----	ANTENNA
-----	ELECTRIC BILGE PUMP HOT
-----	ELECTRIC BILGE PUMP COMMON
-----	ELECTRIC BILGE INLINE FUSE
-----	MAST LIGHTS HOT
-----	MAST LIGHTS COMMON
-----	MAST STEAMING LIGHTS COMMON

**GAGE**  
COAXIAL

**SYMBOLS**

B	BLACK
B	BLACK
G	GREEN
R	RED
B	BLACK
BG	BEIGE
BR	BROWN
C	WHITE
COAXIAL	COAXIAL

# Hunter 28.5

WIRING DIAGRAM THRU HEADLINER AC/DC

- LEGEND:  
 1. COMPASS  
 2. ENGINE  
 3. SHORE POWER INLET  
 4. SWITCH PANEL

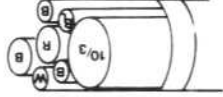
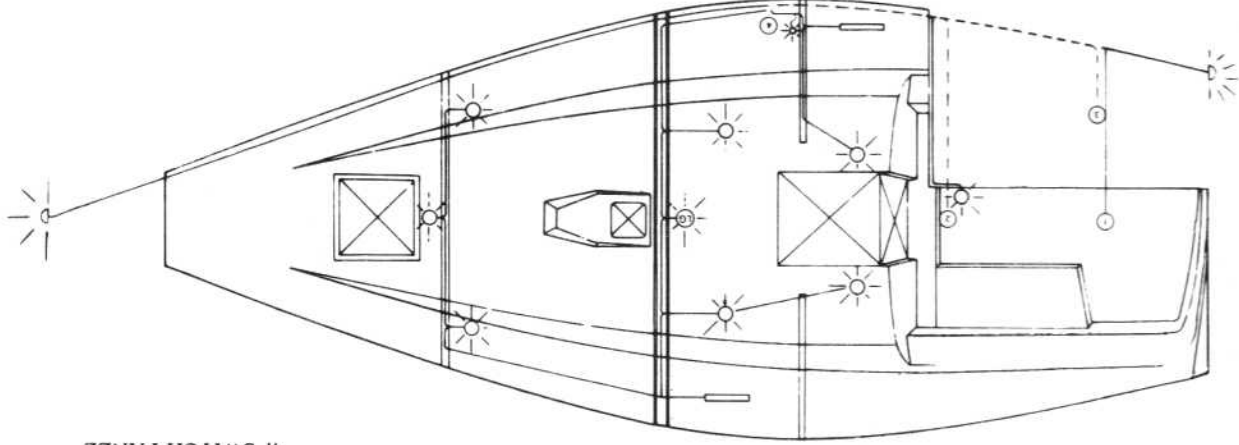

SYMBOL COLOR GAUGE APPLICATION

10/3	WHITE	10	SHORE POWER
R	RED	10	ENGINE HOT
B	BLACK	10	ENGINE COMMON
B	BLACK	16	STERN & COMPASS LIGHT COMMON
B	BLACK	16	CABIN LIGHT
BL	BLUE	16	STERN & COMPASS LIGHTS
W	WHITE	16	CABIN LIGHT

## SYMBOLS:

SMALL CABIN LIGHTS  
 LARGE CABIN LIGHT (LG)  
 BOW AND STERN LIGHTS  
 FLOURESCENT LIGHTS  
 CHART LIGHT

16 GA. BLACK & BLUE WIRES (Cabin Lights)  
 WIRE HARNESS "A"  
 10 GA BLACK & RED WIRES (Engine to switch panel D.C. feed)  
 10/3 BOAT CABLE (Shore power)



# Hunter 28.5

## CONSTRUCTION DETAIL

