

# UNIVERSAL DIESEL

## MODEL 15 & 25

(EARLY MODELS 5411 & 5421)

# SERVICE MANUAL

**medalist**   
**Universal Motors**

Price \$10.00

FORM 7/83



	PAGE
Specifications . . . . .	1-2
Fuel System . . . . .	3-4
Lubrication System . . . . .	5
Oil Filter . . . . .	6
Combustion System . . . . .	7
Valve Timing . . . . .	8
Compression Release . . . . .	9
Pistons and Rings . . . . .	10
Crankshaft . . . . .	10
Connecting Rod . . . . .	11
Cylinder Liner . . . . .	12
Cylinder Head . . . . .	12
Gear Train . . . . .	13
Cam Bearings . . . . .	13
Main Bearings . . . . .	14
Injection Pump . . . . .	15
Flywheel . . . . .	16
Wiring Diagram . . . . .	17
Starting Motor . . . . .	18-19
Glow Plugs . . . . .	19
Reference Chart . . . . .	20-24



SPECIFICATIONS

MODEL	15 (5411)	20 (5416)	25 (5421)	30 (5424)	40 (5432)	50 (5444)
HORSEPOWER	11	16	21	24	32	44
NO. OF CYLINDERS	2	2	3	3	4	4
BORE & STROKE	2.67 x 2.75	2.99 x 3.23	2.84 x 2.76	2.99 x 3.23	2.99 x 3.23	3.3 x 3.25
DISPLACEMENT (CU. IN)	31	45	52	68	91	115
MAXIMUM R.P.M.	3000	2800	3200	2800	2800	3000
COMPRESSION RATIO	22:1	21:1	22:1	21:1	21:1	21:1
TYPE	Vertical, water cooled, 4-cycle diesel engine					
ELECTRICAL EQUIPMENT	12 Volt, 55 AMP Alternator, Electric Starter, and Glow Plugs Mech. Fuel Pump Fuel Pump Fuel Pump Mech. Fuel Pump					
LUBRICATION (Engine)	2.2 Qts. Use SAW 30 HD (CD) or 10W40 heavy duty diesel lubricating oil.	3.7 Qts.	4 Qts.	5.6 Qts.	11.5 Qts.	8.5 Qts.
LUBRICATION (Transmission) (Std and V-Drive)	Fill to full mark on dipstick. Use automatic transmission fluid Type A, Type F, and Dextron II					
TRANSMISSION REDUCTION	2:1	2:1	2:1	2:1	2:1	2:1
COOLING SYSTEM (7 PSI CAP)	Sea-water cooled	4.8 Qts. 14 PSI	Fresh 4.0 Qts. 14 PSI	Water 6 Qts. 14 PSI	Cooling System 8 Qts. 14 PSI	8 Qts. 14 PSI
SEA WATER INLET & OUTLET	3/8" NPT					
EXHAUST FLANGE	1-1/4 NPT	1-1/4 NPT	1-1/4 NPT	1-1/4 NPT	1-1/2 NPT	1-1/2 NPT
FUEL	Diesel fuel number 2-D					

FUEL INLET HOSE 5/16" I.D. 298854 298854 298854 298854 298854 298854

FILTERS, FUEL OIL 298854 298854 298854 298854 298854 298854

FILTERS, LUBRICATION OIL 299381 298852 300209 298852 298852 299927

GOVERNOR Centrifugal type all speeds

ENGINE OPERATING TEMPERATURE 135° to 175° to 175° to 175° to 175° to 175° to 175° to 175° to  
 150° F 190° F 190° F 190° F 190° F 190° F 190° F 190° F 190° F

MAX. OPERATING ANGLE 15° ALL

ENGINE ROTATION Clockwise when viewed from V-Belt end

PROPELLER ROTATION Right Hand (Both STD. and V-Drive)

ENGINE WEIGHT (Pounds) 245 365 285 425 490 545

LENGTH (Overall) 25.6/27.6 (VD) 28.0 28.5/30.5 (VD) 32.5 36.2 36.0

HEIGHT (Overall) 21.2 24.1 22.6 24.6 26.0 26.0

WIDTH (Overall) 20.7 20.7 19.2 20.7 20.7 21.4

INJECTION NOZZLE 299517 299517 299517 299517 299517 299517

INJECTION TIMING 25° before top dead center - all models

# 2. Construction and Handling

## 1 Fuel System

### Fuel system

Fuel system is as shown in Fig. 1. The fuel flows in the direction shown by arrow marks. To bleed air trapped in the fuel, first loosen the vent plug A of the fuel filter. Tighten the plug when no more air bubbles are in the fuel which flows out from the vent. Then proceed to the plug B of the fuel injection pump and vent the system in the same manner as A.

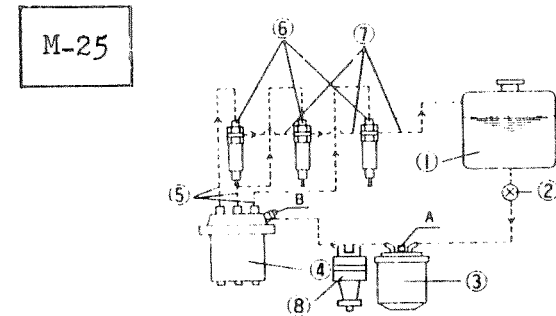
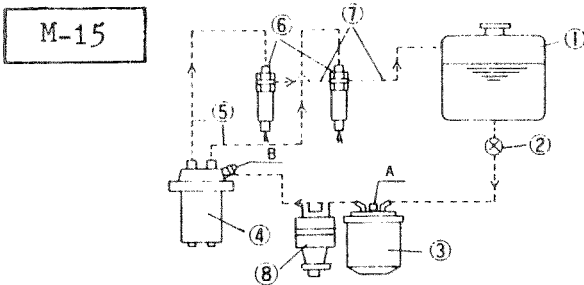

- |                        |                      |
|------------------------|----------------------|
| 1. Fuel tank           | 6. Nozzle holder     |
| 2. Fuel cock           | 7. Overflow pipe     |
| 3. Fuel filter         | A: Vent plug, filter |
| 4. Fuel injection pump | 8. Fuel pump         |
| 5. Injection pipe      |                      |

Fig. 1. Fuel System

### Fuel-filter

The fuel filter is of the cartridge type shown schematically in Fig. 2. Under normal conditions it should only have to be replaced every 400 hours. To install, apply a small amount of fuel to the packing and tighten securely by hand. For removal, the use of a filter wrench...

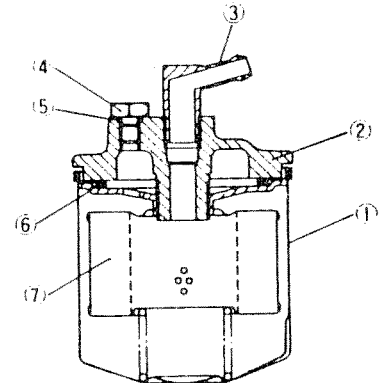

1. Fuel filter
2. Cover
3. Pipe coupling
4. Vent plug
5. "O" ring
6. "O" ring
7. Element

Fig. 2. Fuel Filter

### Fuel injection timing

Fuel injection timing is adjusted by changing the number of shims used between the pump and the gear case it fits into. See Fig. 3. One shim corresponds to approximately 1.5 degrees in crank angle. Therefore, injection will take place 1.5 degrees later when a shim is added and 1.5 degrees earlier when a shim is removed. The timing is correct when the mark punched on the rear end plate lines up with the "F1" marked on the flywheel. See Fig. 4.

Fuel injection pump Speed control lever

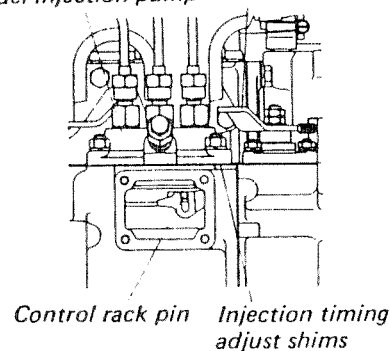

Fig. 3. Adjustment of Injection Timing

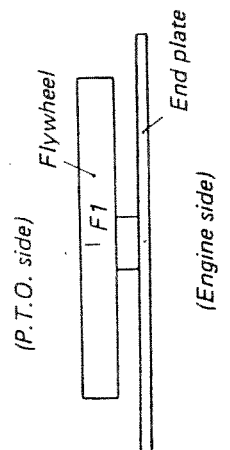
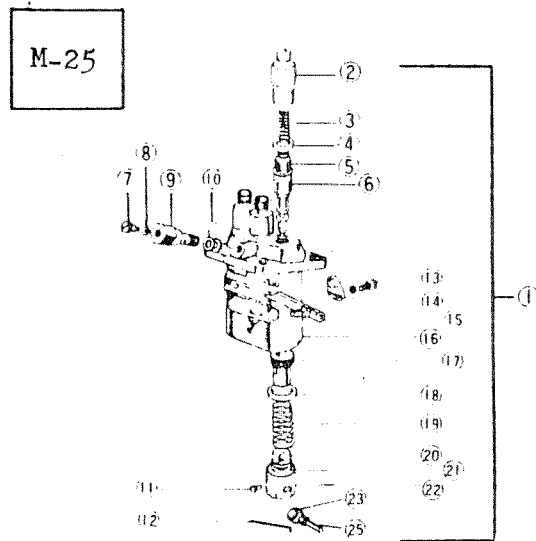
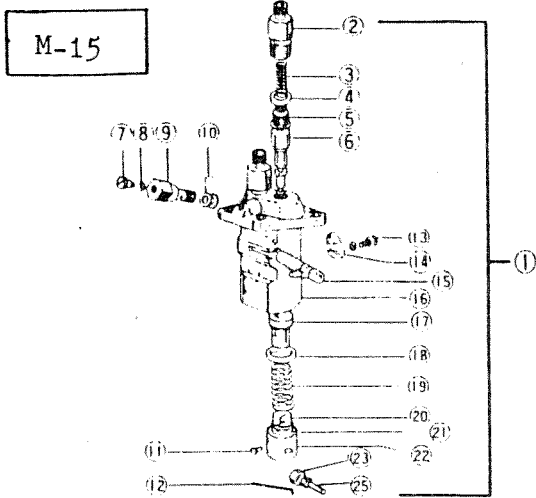

Fig. 4. Inspection of Injection Timing

■ Fuel injection pump



- |                          |                        |
|--------------------------|------------------------|
| 1. Injection pump ass'y  | 14. Adjusting plate    |
| 2. Delivery valve holder | 15. Control rack       |
| 3. Delivery valve spring | 16. Pump housing       |
| 4. Delivery valve gasket | 17. Control sleeve     |
| 5. Delivery valve        | 18. Upper spring sheet |
| 6. Cylinder pump element | 19. Plunger spring     |
| 7. Air bleeder screw     | 20. Lower spring sheet |
| 8. Packing               | 21. Shim               |
| 9. Hollow screw          | 22. Tappet ass'y       |
| 10. Packing              | 23. Roller             |
| 11. Tappet guide pin     | 24. Roller pin         |
| 12. Clamp pin            |                        |
| 13. Bolt                 |                        |

Fig. 5. Fuel Injection Pump

■ Fuel injection pump

The injection pump is the Bosch "Mini K type". Precautions in handling fuel injection pump. Many parts in fuel injection pump are finished precisely. Consequently, even a slight careless handling will very likely result in a serious drop in engine performance. Always bear this in mind and observe the following:

Be very careful of fuel to use, ensure that it is entirely free from water, dirt, and other foreign matters.

Oildrums left outdoors are always considered to contain water, so be sure to have the fuel filtered before using. The water will settle at the bottom of the drum, so refrain from using the fuel to the last drop in the drum.

Clean fuel is a must because the fuel is forced to pass through various important elements of the pump and nozzles and then enter the cylinders, all these parts being so precisely assembled with clearance of 0.00004 in. (1/1000 mm) that they may easily be obstructed or rusted by even a slight amount of water if in the fuel.

■ Installing the injection pump

When installing the injection pump, make certain that the control rack pin is correctly placed in the 0.2 in. (5mm) wide groove of the fork lever (1) before tightening the attaching bolts. Refer to the diagram. If the bolts are drawn down with the rack pin off the groove, the rack may over travel and stick in this position. This would cause excess fuel flow, allowing the engine to overspeed which would result in engine failure.

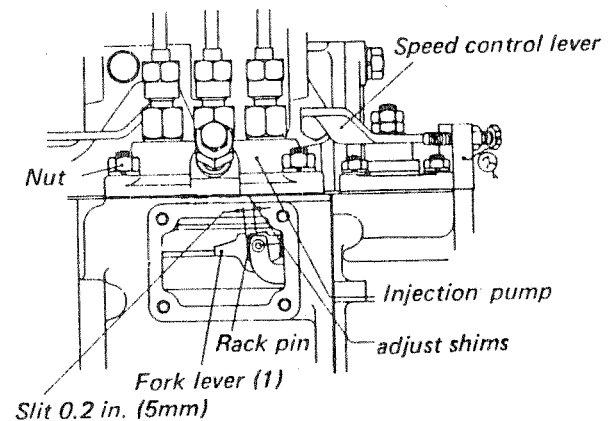



### ■ Fuel injection nozzle

The fuel injection nozzle, like the fuel injection pump, is also a precision piece of equipment and should be treated with the same amount of care.

### ■ The injection pressure

The injection pressure is adjusted by adding or subtracting shims from the top of the nozzle spring. Adding a 0.004 in. (0.1 mm) shim will increase the injection pressure by about 142 psi (10 kgf/cm<sup>2</sup>). The injection pressure is 1990 to 2133 psi. (140 to 150 kgf/cm<sup>2</sup>)

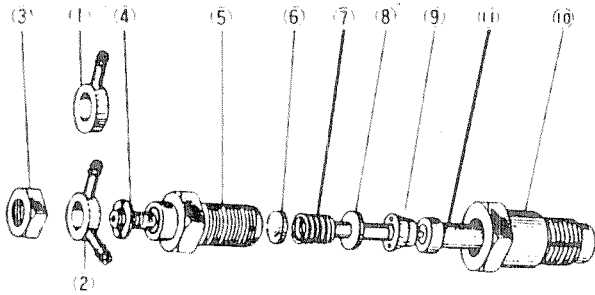

- |                       |                        |
|-----------------------|------------------------|
| 1. Delivery nipple 1  | 7. Nozzle spring       |
| 2. Delivery nipple 2  | 8. Pressure pin        |
| 3. Nut                | 9. Pressure pin holder |
| 4. Washer             | 10. Nozzle nut         |
| 5. Nozzle holder body | 11. Nozzle piece       |
| 6. Adjusting washer   |                        |

Fig. 6. Fuel Injection Nozzle

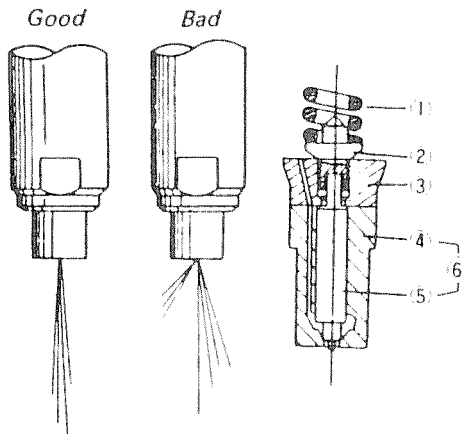

- |                        |                 |
|------------------------|-----------------|
| 1. Nozzle spring       | 4. Nozzle body  |
| 2. Pressure pin        | 5. Needle valve |
| 3. Pressure pin holder | 6. Nozzle piece |

Fig. 7. Nozzle

### ■ Spray pattern

The injection pressure and fuel spray pattern are most accurately checked by using a nozzle pressure tester. If a nozzle pressure tester is not available, remove the nozzles from the engine, leaving the pressure lines connected.

### [[CAUTION]]

Hold the nozzles so that the high pressure spray from them will not in any way impinge upon unprotected skin. The atomized fuel will easily penetrate the skin and cause blood poisoning.

Set the speed control lever at W. O. T. and operate the starter. The needle valve, if it is working properly, will produce a high pitched pulsating sound like that of a flute as fuel is sprayed out. If this sound is not heard or other problems are noted, refer to the "Fuel Injection Pump & Nozzle Maintenance Std." in 4.1 in "Engine".

### [[Precaution]]

- (1) Assembly and disassembly of the nozzle should be done in fresh clean fuel.
- (2) The nozzle should always be installed as an assembly, never by component parts.
- (3) Remember never to let the nozzle spray contact unprotected flesh.
- (4) Tighten the retaining nut to 43.5 to 58 ft-lb (6 to 8 kgf-m) Any torque higher than this will cause slow action of the needle valve and poor injection.

## 2.2 Lubrication System

### ■ Oil pump pick-up screen

The oil pump pick-up is located in the crankcase as shown in Fig. 9 and is fitted with a metal screen. If the screen becomes plugged, wash it off with diesel fuel or kerosene.

### ■ Lubrication system

The trochoid oil pump suck up lubricating oil through oil filter and the oil flows down to the filter cartridge where it is further completely filtered and also the pressure regulating valve installed in the gear case regulate the oil pressure at 36 ~ 50 psi (2.5 ~ 3.5 kgf/cm<sup>2</sup>). From the filter, one part of the lubricating oil will be fed through crank shaft passage to crank pin metal and the remainder of oil will be fed through the frame to the rocker arm shaft. An oil pressure switch is provided for on the way for watching the oil pressure. If the oil pressure falls below 7.1 psi (0.5 kgf/cm<sup>2</sup>), the oil warning lamp\* on the dash panel will be lighted warning the operator. In case the oil warning lamp should stay on while engine, being running at normal revolution, shut the engine off immediately and check the causes of the pressure drop.

### NOTE

\*Oil warning lamp and dash panel are optional parts.

[[ Probable cause of low oil pressure ]]

- (1) Clearance on one of the bearings is too great.
- (2) One of the rocker arms is too loose.
- (3) Faulty pressure regulating valve; pressure lower than normal (replace the oil filter or clean the valve on the old one with kerosene or diesel fuel.)

M-15

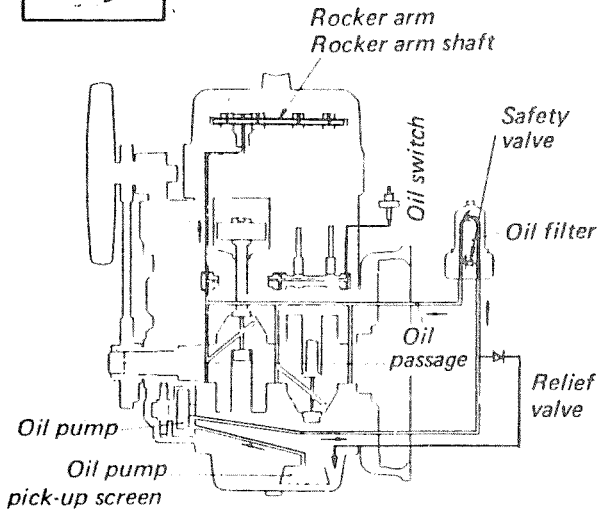

M-25

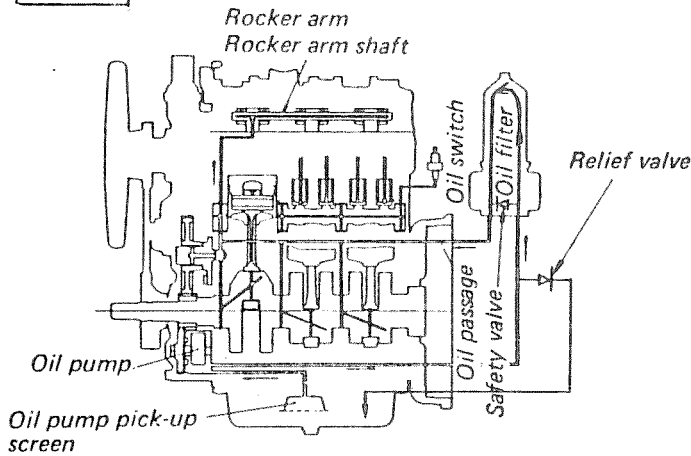

Fig. 8. Lubrication System

■ Oil filter

- (1) Replace the oil filter at every other oil change (every 150 hours)
- (2) Under normal conditions it is only necessary to change the oil filter at the specified intervals. If, however, the engine is used in EXTREMELY dirty conditions, the pressure regulating valve should also be removed and cleaned.
- (3) Whenever the oil filter is replaced, run the engine under no load for a few minutes until the filter has been filled and then add oil to make up for what is contained in the filter.

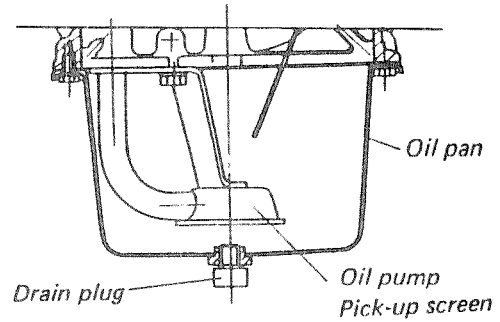

Fig. 9. Detail of Oil Pump Pick-up

Construction of Oil Filter

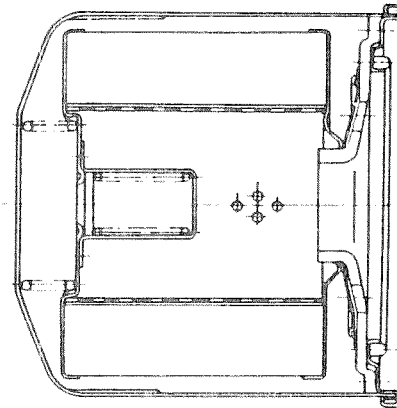
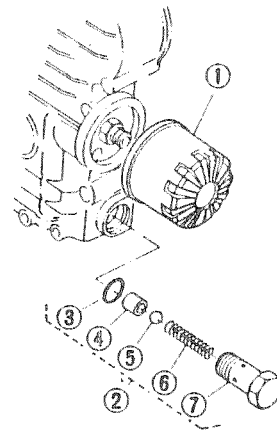

Fig. 10. Oil Filter

Construction of Relief Valve



1. Oil Filter Cartridge
2. Relief Valve Assy
3. O Ring
4. Valve Seat
5. Ball
6. Spring
7. Relief Valve Body

Fig. 11. Pressure Regulating Valve

■ Replacing engine oil

- (1) Drain and replace the engine oil after the first 35 hrs of operation and every 75 hrs thereafter.
- (2) The oil is easier to change if the engine is warm.
- (3) Do not mix different brands of oil. If a different brand of oil must be used, drain the oil and replace with all one brand. Also, do not mix oils of different viscosities.

2.3 Combustion System

■ Combustion chamber

The engine utilizes a swirl type pre-combustion chamber (Fig. 12). Fuel and air are mixed in this chamber resulting in more efficient combustion. A glow-plug is employed to preheat the fuel for easy starts down to 5°F (-15°C).

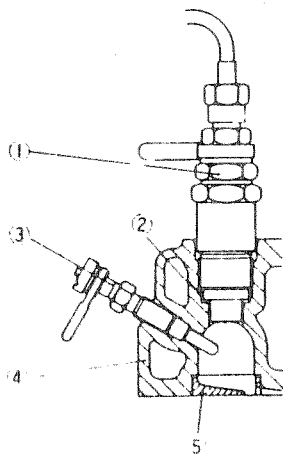

1. Nozzle holder
2. Nozzle piece packing
3. Glow plug
4. Cylinder head
5. Combustion chamber

Fig. 12. Combustion Chamber

■ Valve

Combustion air, of course, is brought in through the intake valve when the descending piston creates a partial vacuum in the cylinder.

Valve stem seals should be replaced whenever they are removed. If the stem seal are replaced, coat the stem liberally with oil before inserting in the valve guide to prevent burning the valve stem seal.

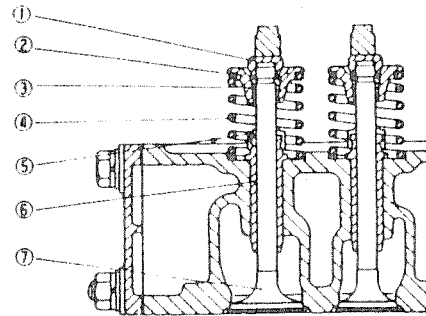

1. Valve cap
2. Valve spring retainer
3. Valve spring collet
4. Valve spring
5. Valve stem seal
6. Valve guide
7. Valve

Fig. 13 Structure of Valves

The dimensions of the replacement valves and valve guides are shown in Fig. 14. When new valve guides are installed, the bores should be reamed to 0.276 to 0.277 in. (7.01 to 7.025mm) after installation. The valve head must be recessed 0.035 to 0.043 in. (0.9 to 1.1mm) from the face of the cylinder head to prevent it from hitting the top of the piston.

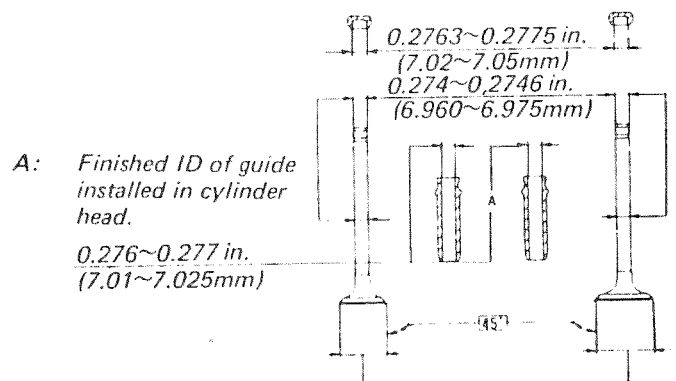

M-15	0.921~0.929 in. (23.4~23.6mm)	1.059~1.067 in. (26.9~27.1mm)
M-25	1.078~1.086 in. (27.4~27.6mm)	1.216~1.224 in. (30.9~31.1mm)

Fig. 14. Standard Dimensions of Valves, Valve Guides, Valve Gap

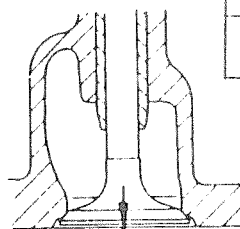

0.035~0.043 in. (0.9~1.1mm)

Fig. 15. Sinking of Valve

■ Valve timing

When the valve clearance has been adjusted as shown in Fig. 16, the standard valve timing shown in the chart can be attained:

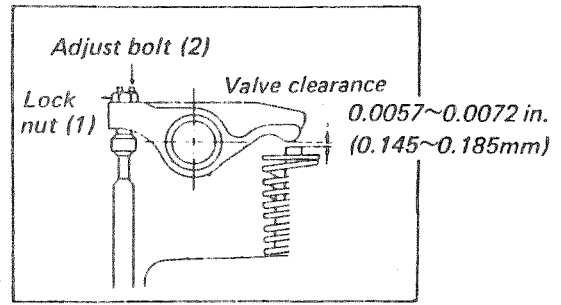

Fig. 16. Adjustment of Valve Clearance

Intake valve opens	20° B TDC
Intake valve closes	45° A BDC
Exhaust valve opens	50° B BDC
Exhaust valve closes	15° A TDC

Valve clearance: 0.0057 to 0.0072 in. (0.145 to 0.185 mm) with engine cold.

■ Rocker Arms

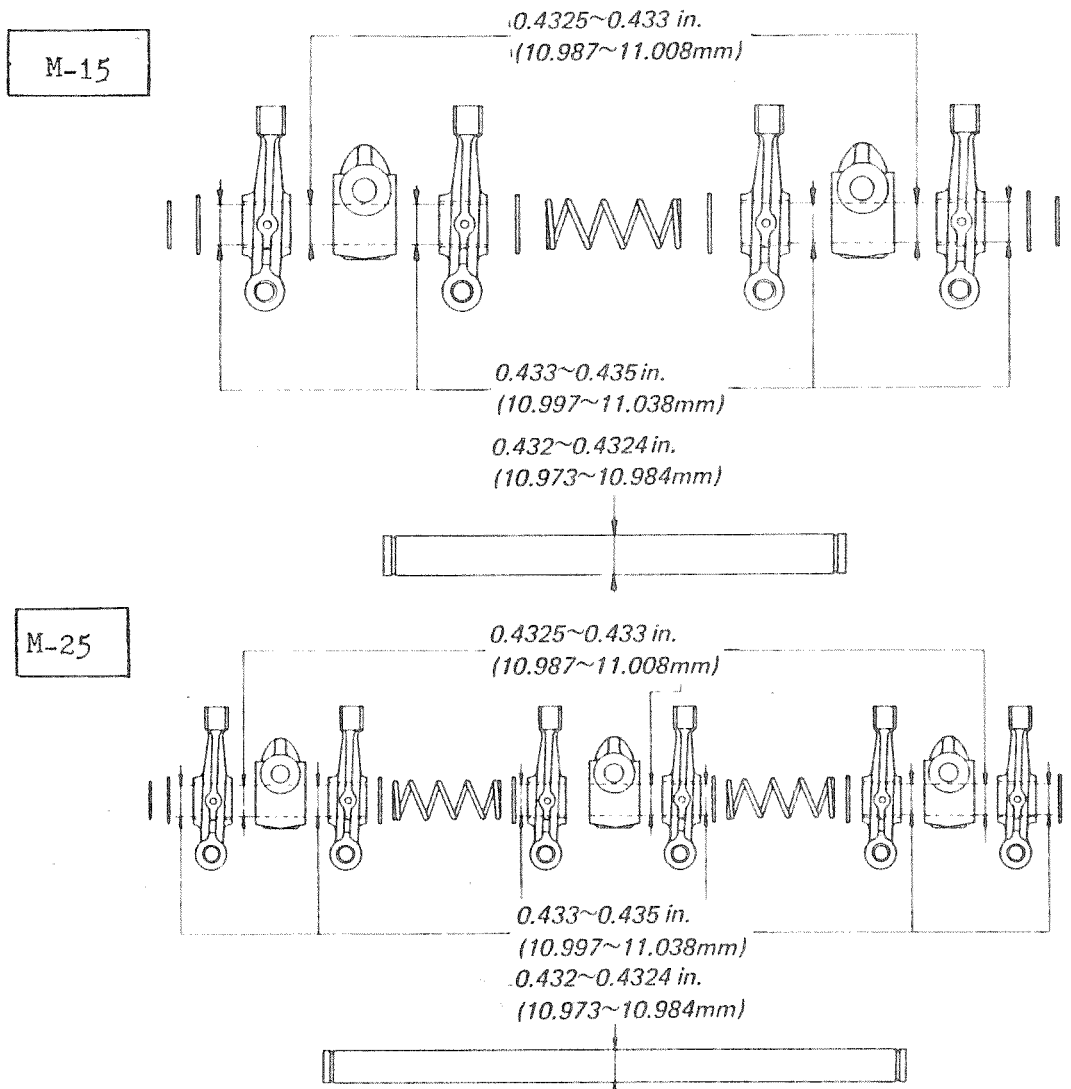

Fig. 17. Standard Relative Position of Rocker Arms

■ Compression release (Release wire is optional parts)

Assemble the parts as shown in Fig. 18. Pull the lever out as far as it will go, check to see that the 55° angle is attained and that compression is released. The compression release is to be used when the battery is low or when starting in cold weather. To use the compression release, preheat the glow-plug as usual, pull the compression release knob out as far as possible and hold it there while cranking the engine. This partially releases the engine compression enabling it to turn faster in cold weather or when the battery is low. Once the engine is turning fast enough to start, release the lever and the engine will start.

(NOTE)

Make sure the compression release has returned to the operating position by pushing the knob all the way in.

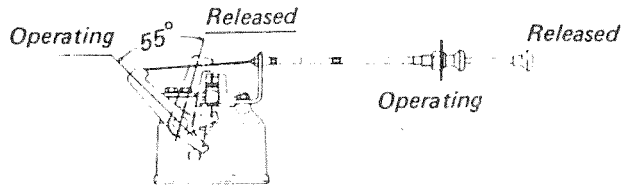

Fig. 18. Compression Released

[[CAUTION]]

Do not pull the compression release lever when the engine is running at high speed or under load. If it is necessary to use the compression release while the engine is running reduce the speed to idle before doing so.

■ Adjustment of compression release

- (1) Set exhaust valve in totally closed position.
- (2) Remove decompression adjustment window cover from cylinder head cover.
- (3) Make valve clearance as "0" with use of decompression adjust bolt. From this position, turn the bolt further by 1 to 1.5 turns. Decompression clearance will then be set at 0.030 to 0.044 in. (0.75 to 1.125mm), which is the designed clearance.
- (4) After adjusting, be sure to lock adjust bolt securely so that it will not unturn while engine is in service.
- (5) Make certain that the clearance is not too wide. To check this, turn crankshaft by hand and make certain valve disk does not contact with piston top.

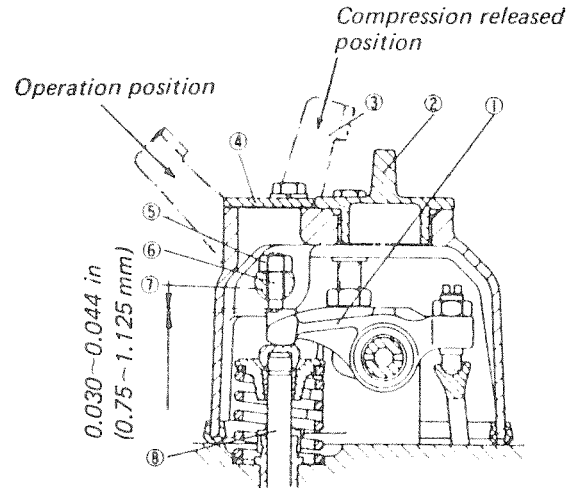

- |                              |                             |
|------------------------------|-----------------------------|
| 1. Rocker arm                | 5. Compression release nut  |
| 2. Oil filler cap            | 6. Compression release bolt |
| 3. Compression release lever | 7. Shaft                    |
| 4. Adjustment access cover   | 8. Valve                    |

Fig. 19. Adjustment of Compression Released

■ Top clearance

Top clearance should be 0.0236 to 0.0314 in. (0.6 to 0.8 mm). To adjust, use cylinder gasket shims, 0.0078 in. (0.20mm) thick each, onto the head side.

For checking the measurement, place a piece of fuse on the piston top and fix the cylinder head securely on the cylinder-head flange. The measurement is taken by the fuse. The liner is level with the cylinder frame at top surface.

The gasket shims can be reused, so do not lose them.

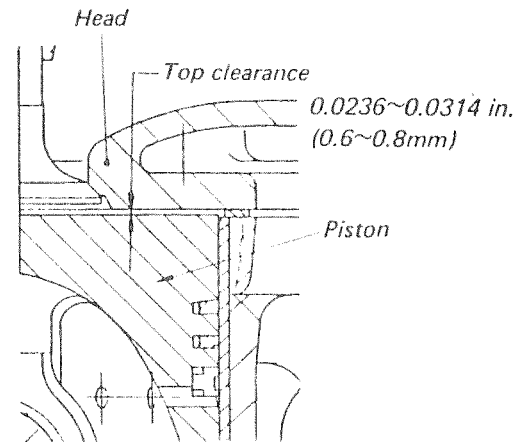

Fig. 20. Top Clearance

## 2.4 Main Moving Parts

### ■ Pistons and piston rings

The pistons and piston rings are shown in Fig. 25. If the cylinder liners have been bored oversize, oversize pistons and rings must be used. The piston is made of high silicon Al-Alloy and is cam ground. The top compression ring is a chrome plated keystone type, the second compression ring is discontinuous and undercut and the oil control ring is of the standard expansion type.

- B : End gap of rings on piston in cylinder
- I : Diameter of piston skirt thru  $\phi$  of piston pin bore
- E : Diameter of piston skirt perpendicular to piston pin

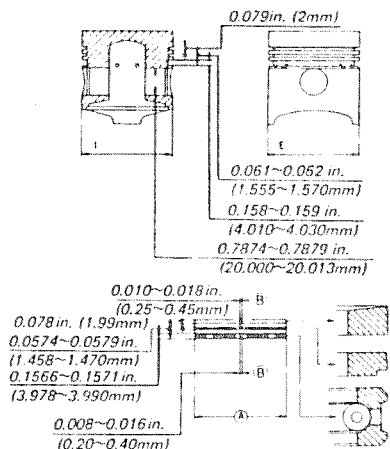

Fig. 25. Standard Dimensions of Piston and Piston Rings

	Standard size	Over size	
Ⓐ	2.677 in. (68mm)	2.6968 in. (68.5mm)	MODEL 15
I	2.6718~2.6726 in. (67.865~67.885mm)	2.6915~2.6923 in. (68.365~68.385mm)	
E	2.6742~2.6750 in. (67.925~67.945mm)	2.6938~2.6946 in. (68.425~68.445mm)	
Ⓐ	2.8346 in. (72mm)	2.8543 in. (72.5mm)	MODEL 25
I	2.8293~2.830 in. (71.865~71.885mm)	2.8490~2.8498 in. (72.365~72.385mm)	
E	2.8317~2.8325 in. (71.925~71.945mm)	2.8514~2.8522 in. (72.425~72.445mm)	

### ■ Crankshaft and connecting rod

- (1) The crankshaft is a heat treated steel alloy forging. The crank pins are induction hardened for additional wear resistance. Crankshaft endplay is 0.006 to 0.012 in. (0.15 to 0.31 mm).
- (2) The crankpin bearings are aluminum.  
When installing the connecting rods:
  - a) Clean both surfaces thoroughly.
  - b) Apply engine oil to the threads of the connecting rod capscrews before installing and tighten each to 19.5 to 22.4 ft-lbs. (2.7 to 3.1 kg-m).

The bearing caps are matched to each connecting rod and should not be interchanged. Also, since there are variations in machining from side to side, each bearing cap and connecting rod are marked and should be assembled so that the marks line up.
- (3) In the event that the crankpins become worn and are no longer serviceable, undersized bearings may be used. When installing the undersize bearings observe the following precautions:
  - a) Machine the crankpin diameter and radii to within a few thousandths of the correct dimensions and finish grind to the exact dimensions.
  - b) After finish grinding the bearing diameter and the radii, chamfer the diameter of the oil hole with an oilstone. If this is not done an oil film will not form and the bearing will seize.
  - c) The crankpin should always be super-finished to 0.000016 in. (0.0004 mm) or less.
  - d) Select the bearing from the chart that necessitates the removal of the least amount of metal from the crankpin. Do not deviate from the chart dimensions as the bearing life will be reduced if they are machined.
  - e) To determine the running clearance, assemble the connecting rod, bearing cap and bearing as described in section 2 and measure the diameter anywhere within the 120° angle indicated in Fig. 27 and subtract the crankpin diameter from this figure.
  - f) The piston pin bushings are of lead bronze. The inside diameter of the bushing should be finished to 0.7884 to 0.7890 in. (20.025 to 20.040 mm).

Over size	Name of Part	Part No.	Mark	
0.02 in. (0.5mm)	Piston 05 Piston ring 05		05 OS 05 OS	M-15
	Cylinder liner			
0.02 in. (0.5mm)	Piston 05 Piston ring 05		05 OS 05 OS	
	Cylinder liner	2.6968~2.6976 in. (68.5000~68.519mm) (1.2μR max to 2μR max) by honing		
0.02 in. (0.5mm)	Piston 05 Piston ring 05		05 OS 05 OS	M-25
	Cylinder liner	2.854~2.855 in. (72.5000~72.519mm) (1.2μR max to 2μR max) by honing		

M-15

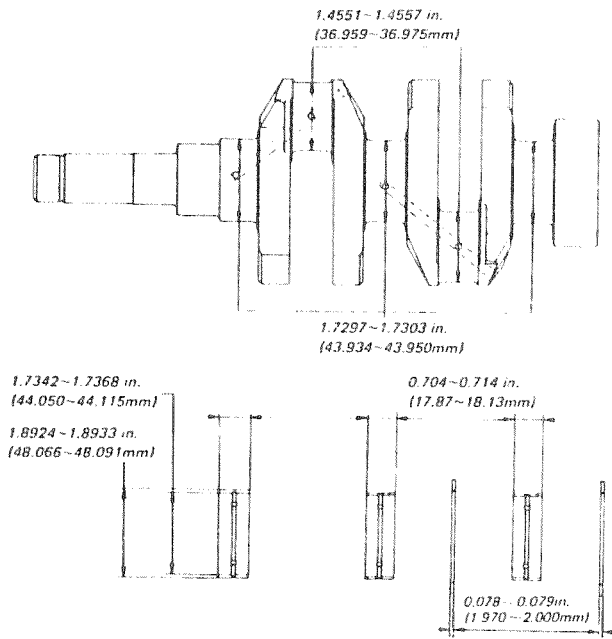

M-25

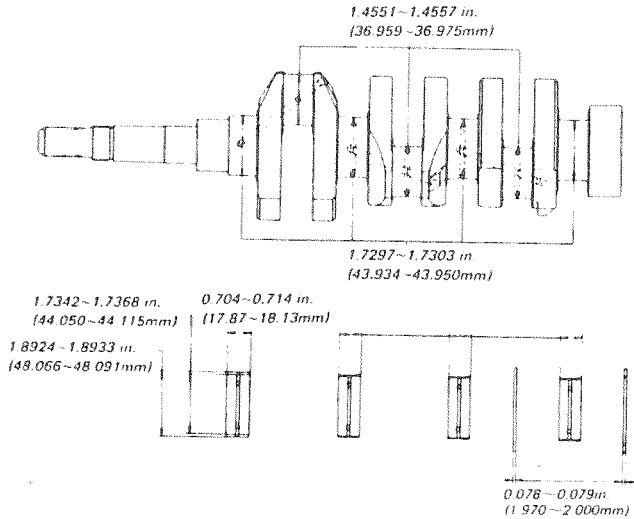

Fig. 26. Standard Dimensions of Crankshaft and Bearings

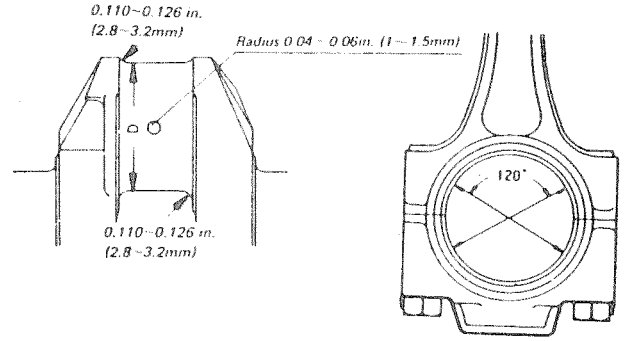
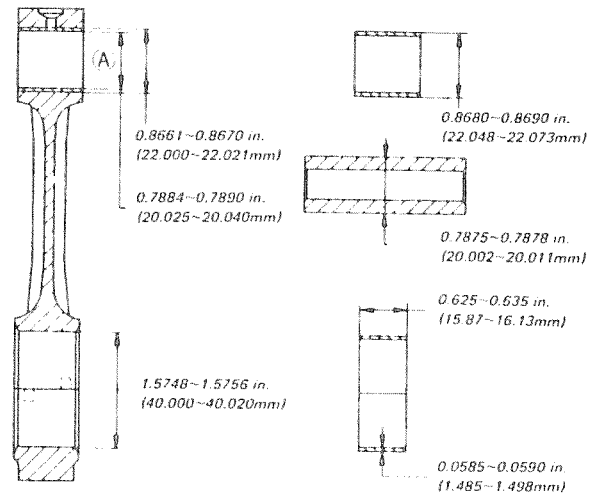

Fig. 27. Crankpin for Undersize Bearing



(A): Diameter of piston pin bushing after installation

Fig. 28. Standard Dimensions of Connecting Rod Bearing and Bushing

Size	Part No.	Bearing	Crankpin Diam.	Metal Mark	Running Clearance in (mm)
02		0.007874 in. (0.20mm) undersize	1.4472~1.4478 in. (36.759~36.775mm)	02 US	0.0011~0.00358 in. (0.029~0.091mm)
04		0.015748 in. (0.40mm) undersize	1.4393~1.440 in. (36.559~36.575mm)	04 US	

■ Boring and replacing the cylinder liner

Referring to Fig. 21, the inside diameter of the liner should be checked at points 1, 2, and 3 and in the directions (a) and (b). The liner on which the wear has exceeded the service limit can be bored and honed to 0.020 in. (0.50mm) oversize. The finished dimensions are

2.677 to 2.6779 in. (68.000 to 68.019mm), for Model 15, and 2.834 to 2.835 in. (72.000 to 72.019mm) for Model 25. An oversized piston and rings must then be used with this liner. Once this oversized liner has exceeded its wear limit, it should be replaced with a new one. To install a new liner, coat the outside liberally with oil, push into the block with a press and finish to the standard size. When this is done, a standard size piston must again be used.

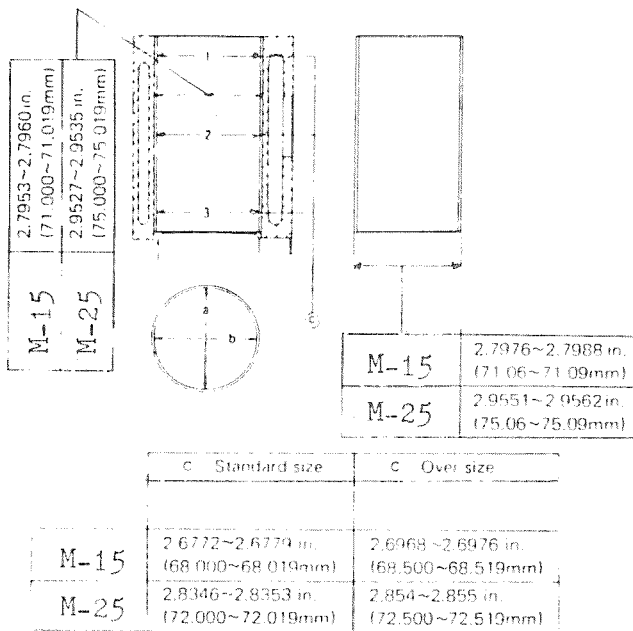

Fig. 21. Standard Dimensions of Cylinder Liner and Liner Bore in Block

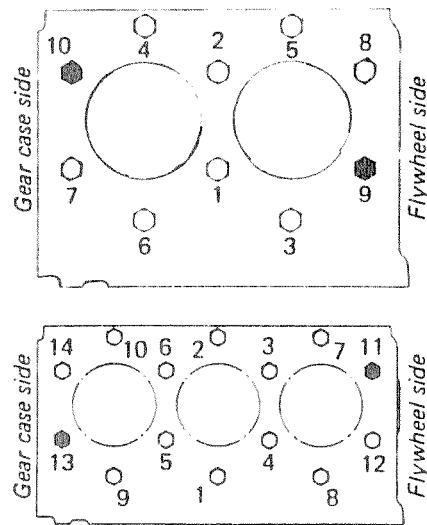

Fig. 22. Tightening of Cylinder Head Bolts

■ Tightening cylinder head capscrews (Fig. 22)

- (1) The tightening torque of the cylinder head capscrews is 31 to 35 ft.-lbs. (4.3 to 4.8 kg-m) for Model 15, and 43 to 47 ft.-lbs. (6.0 to 6.5 kg-m) for Model 25. Numbers 9, 10 and 11, 13 (◆) in the diagram are studs. The nuts on these studs should also be tightened to this torque.
- (2) All the capscrews must be tightened uniformly. To do this, tighten all the capscrews in the order indicated on the diagram until they are just snug. Then tighten each one 1 (one) turn at a time in this same sequence each time until all have been tightened to the required torque.
- (3) The cylinder head capscrews should be re-tightened if the engine has not been used for a long time. The valve lash should also be adjusted each time the cylinder head capscrews are retorqued. If the cylinder head gasket has been replaced, run the engine for about 30 minutes and re-tighten the cylinder head capscrews as described above.



## 2.5 Main Components

### ■ Gear train

Be sure to assemble the gears by matching the mating marks as shown in Fig. 29. The backlash of each gear is 0.00163 to 0.00454 in. (0.0415 to 0.1154 mm).

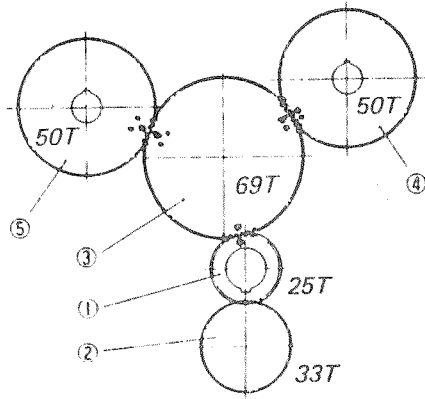

- |                        |                                   |
|------------------------|-----------------------------------|
| 1. Crankshaft gear     | 4. Camshaft gear                  |
| 2. Oil pump drive gear | 5. Fuel injection pump drive gear |
| 3. Idle gear           |                                   |

Fig. 29. Mating Marks of Gear Train

### ■ Crankshaft gear

Heat to about 176°F (80°C) and slide on crankshaft. If the shaft and bore dimensions are such that the gear will not slide easily, it may be heated to a slightly higher temperature for installation.

### ■ Camshaft gear

Referring to Fig. 30, place retainer plate (3) on camshaft (2) first. Make certain the clearance of the retainer plate to the camshaft end is made 0.003 to 0.009 in. (0.07 to 0.22mm). When camshaft gear (1) is in place. Then heat the camshaft gear to about 176°F (80°C) and push into place. If the interference should be excessive and there are fears that the shaft would be damaged, raise the heating temperature further to make the gear softer, allowing an easier fit.

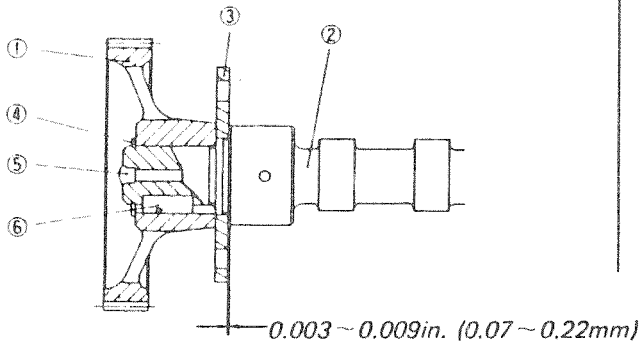

- |                            |             |
|----------------------------|-------------|
| 1. Camshaft gear           | 4. Cir-clip |
| 2. Camshaft                | 5. Pin plug |
| 3. Camshaft retainer plate | 6. Key      |

Fig. 30. Assembly of Camshaft Gear with Camshaft

### ■ Camshaft and camshaft bearings

Standard dimensions are shown in Fig. 31. Camshaft running clearance is: 0.002 to 0.0036 in. (0.05 to 0.091mm).

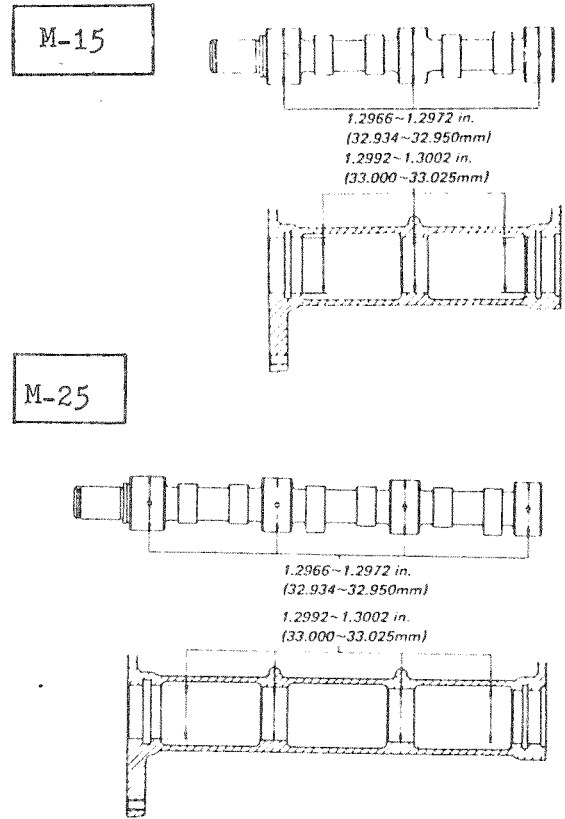
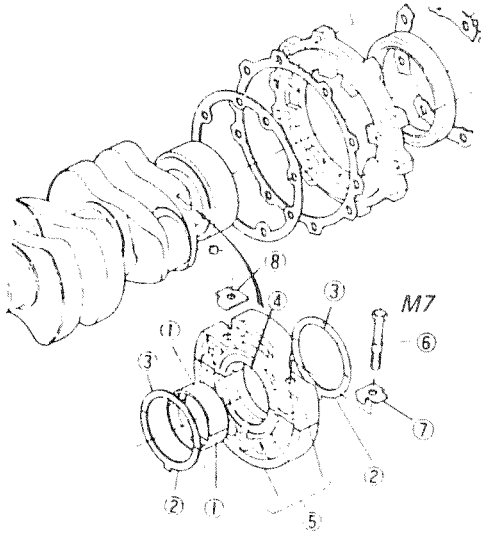

Fig. 31. Standard Dimensions of Camshaft and Bearings

■ Main bearing ass'y

Insert the bearings in the main bearing housing halves as indicated in Figs. 32 & 33, using the thrust washers only on the journal nearest the flywheel. Coat the crankshaft journals and the bearing surfaces with engine oil, place the housing halves with bearings on the crankshaft, coat the capscrew threads with engine oil and tighten to 14.5 to 17.5 ft-lbs (2 to 2.4 kg-m) –M7.



1. Bearing
2. Thrust washer
3. Thrust washer
4. Crankshaft journal
5. Main bearing
6. Cap screw
7. Locking tab
8. Locking tab

Fig. 32. Main Bearing Housing 1 with Thrust Washers

■ Main bearing housing

Installation of crankshaft with main bearings in engine block. Slide the crankshaft assembly into the engine block, being careful not to nick or scrape the crankpins. After the assembly is in position make sure the oil passages are correctly lined up. Install the main bearing housing to engine block locking cap screw and washer from the side to position the housing and then install cap screw (2) from the bottom and torque to 21 to 25 ft-lbs (3 to 3.5 kg-m) – M8.

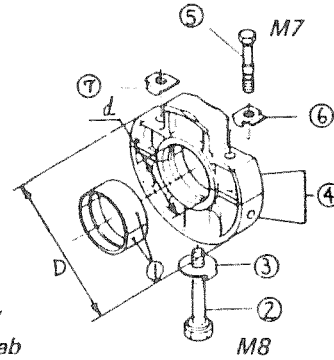

1. Bearing
2. Cap screw
3. Locking tab
4. Main bearing housing
5. Cap screw
6. Locking tab
7. Locking tab

Fig. 33. Main Bearing Housing 2  
Main Bearing Housing 3

	D	d	
Main bearing housing 1	4.4083~4.4089 in. (111.973~111.988mm)	1.8897~1.8904 in. (48.000~48.016mm)	M-15 & 25
Main bearing housing 2	4.3887~4.3893 in. (111.473~111.488mm)		M-25
Main bearing housing 3	4.3690~4.3696 in. (110.973~110.988mm)		M-15 & 25

■ Hydraulic oil pump drive unit, **NOT AVAILABLE**

Assemble as shown in Fig. 34.

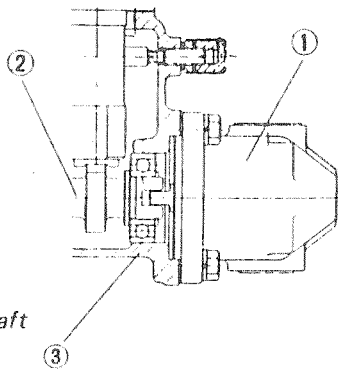

1. Oil pump
2. Injection pump camshaft
3. Engine block

Fig. 34. Hydraulic Oil Pump Drive Unit

■ Idler gear

Secure the idler gear shaft to the engine block with 3 cap-screws, torque to 7.23 to 8.32 ft-lbs (1 to 1.15 kg-m) and bend tabs of tab washer. Install gear as shown make sure it runs freely, has a running clearance of 0.0006 to 0.0018 in. (0.016 to 0.045mm) and 0.008 to 0.020 in. (0.20 to 0.51mm) end play.

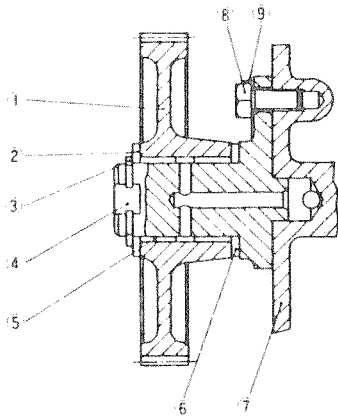

1. Idler gear
2. Spacer
3. Retaining ring
4. Shaft
5. Bushing
6. Spacer
7. Engine block
8. Capscrew
9. Tab washer

Fig. 35. Idler Gear

■ Injection pump camshaft

Injection pump camshaft, Fig. 36. Install the bearings and governor unit on the camshaft and install in the engine block. Hour Meter Unit, Fig. 36. Insert the "tang" on the end of the hour meter drive shaft into the slot on the end of the injection pump camshaft and install as per the illustration.

Structure of Fuel Cam Shaft

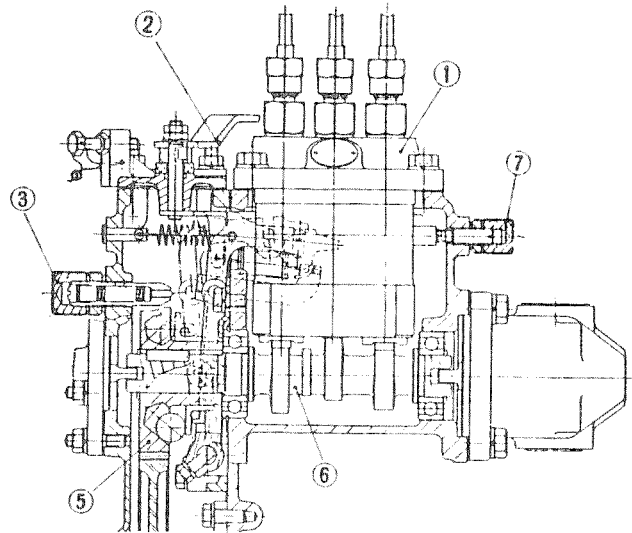

1. Injection Pump
2. Speed Adjusting Lever
3. Fuel Control Device
5. Injection Pump Gear
6. Fuel Cam shaft
7. Idling Limiting Device

Fig. 36. Injection Pump Camshaft Assy

■ **Attaching flywheel to crankshaft**

Clean the entire contact surface carefully. Coat the contact surface with engine oil, wash all the oil off with gasoline and dry it thoroughly. Put the flywheel on and torque the capscrews to 40 to 43.38 ft-lbs (5.5 to 6 kg-m). Bend the locking tabs back on the washers.

■ **Tensioning of fan belt.**

The fan belt tension is adjusted by moving the tension pulley bracket in or out. The belt is properly tensioned when the belt deflection midway between the tension pulley and the crankshaft pulley is 0.25 to 0.35 in. (7 to 9mm) with a force of 20 lbs applied. Proper belt tension is essential for good engine cooling and belt life. See Fig. 37.

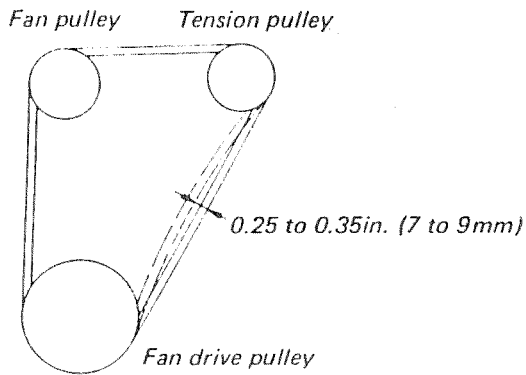

Fig. 37. Fan Belt Tensioning

■ **Radiator**

- (1) Rust inhibitor and antifreeze should be used in accordance with the recommendations in the related manuals.
- (2) Be sure to remove all debris that may be plugging the fins.
- (3) Check the rubber shock mount nuts periodically to be sure they are tight.

■ **Cooling water pump, fresh water**

To install the cooling fan pulley on the pump, securely tighten the nut (4) to 50.6 to 57.9 ft-lbs. (7 to 8 kgf-m) torque.

Model 25

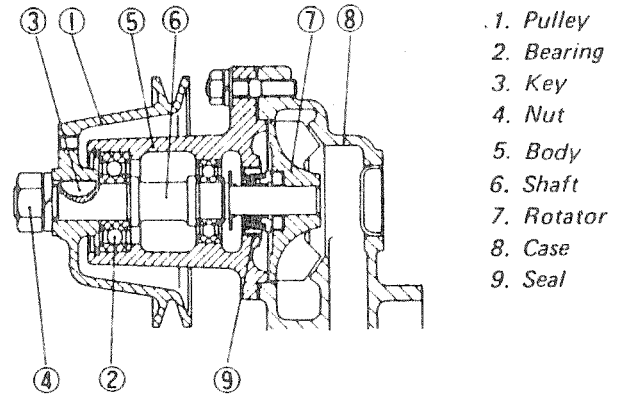

Fig. 38. Water Pump

# Electrical System

ENGINE CONNECTIONS

# Universal Diesel

PANEL CONNECTIONS

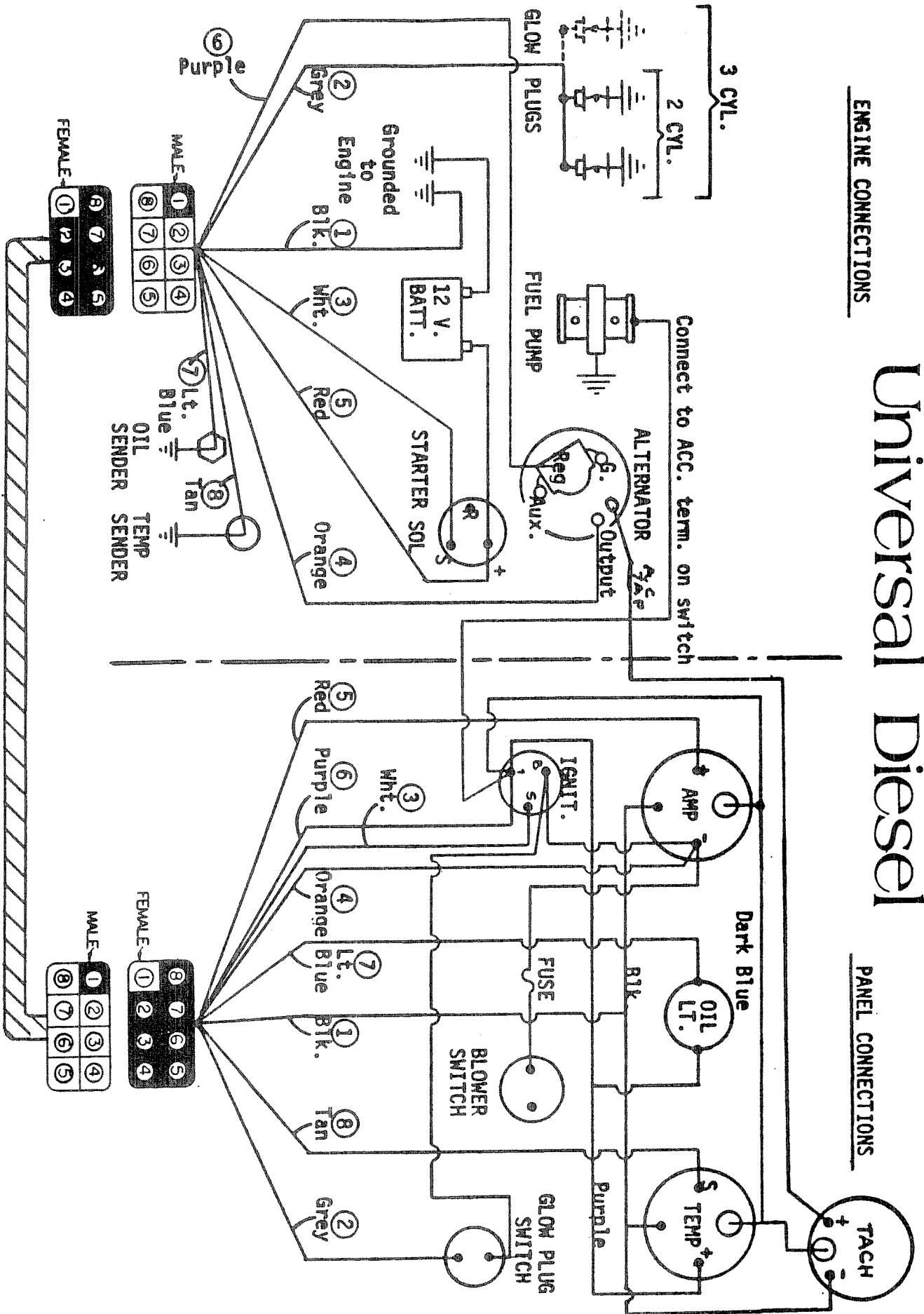

### 3.3 Starting Motor

The starting motor employed in this engine is of the roller clutch type starter, in which magnetic force operates the lever, thereby pushing the drive pinion in the ring gear. This is the most popular type of starting motor.

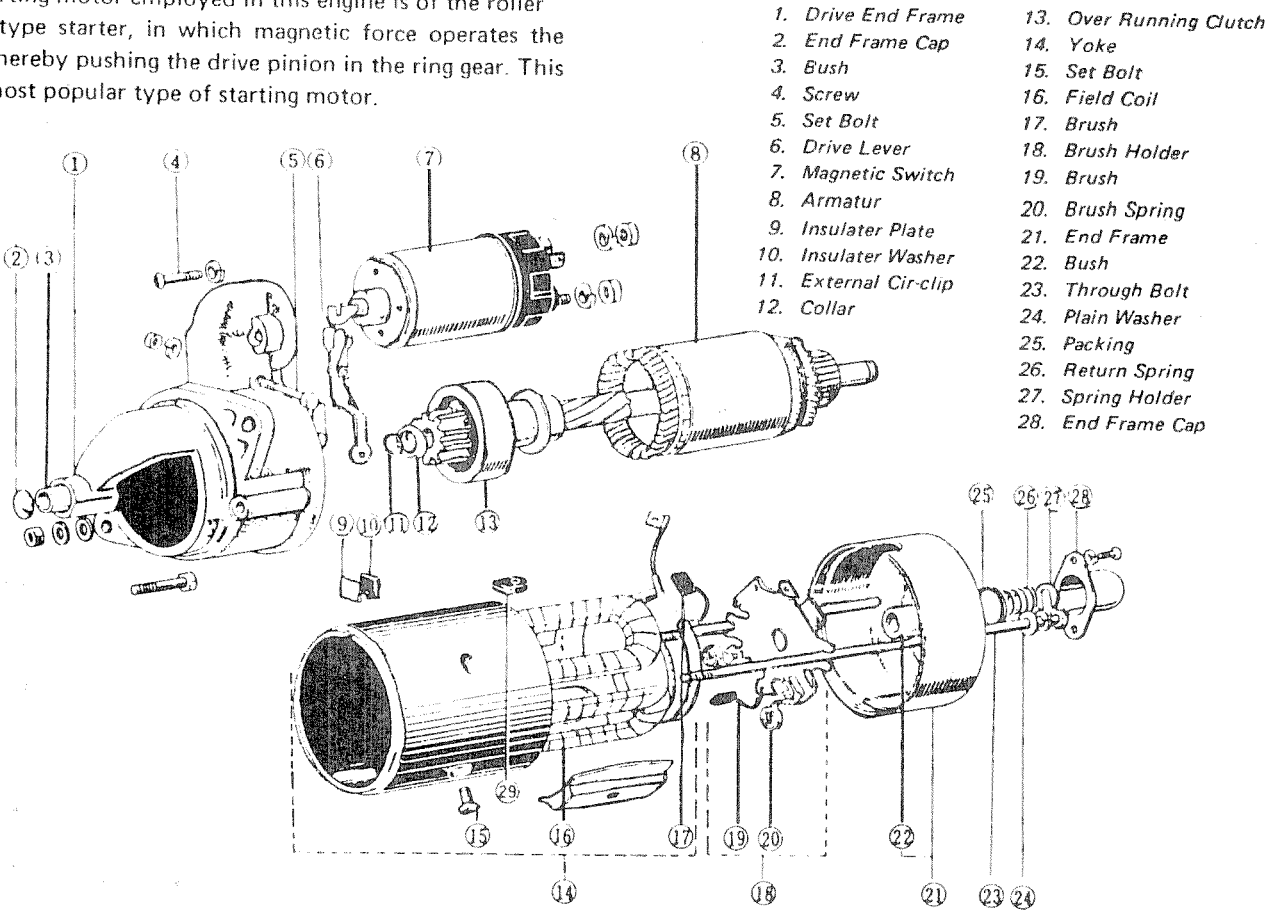

- 1. Drive End Frame
- 2. End Frame Cap
- 3. Bush
- 4. Screw
- 5. Set Bolt
- 6. Drive Lever
- 7. Magnetic Switch
- 8. Armatur
- 9. Insulator Plate
- 10. Insulator Washer
- 11. External Cir-clip
- 12. Collar
- 13. Over Running Clutch
- 14. Yoke
- 15. Set Bolt
- 16. Field Coil
- 17. Brush
- 18. Brush Holder
- 19. Brush
- 20. Brush Spring
- 21. End Frame
- 22. Bush
- 23. Through Bolt
- 24. Plain Washer
- 25. Packing
- 26. Return Spring
- 27. Spring Holder
- 28. End Frame Cap

Fig. 41.

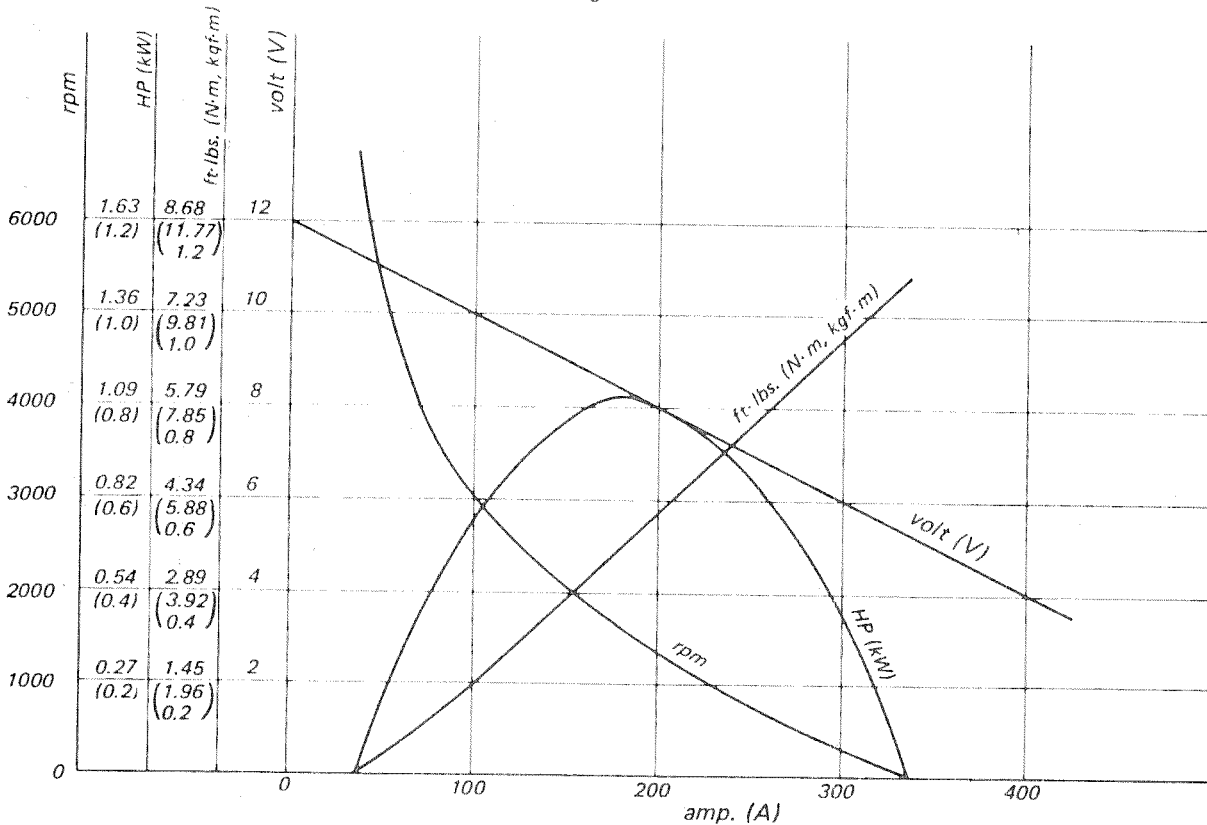

Fig. 42.

● Specifications of Starting Motor

Code No.	
Type	Roller Clutch Type
Nominal Voltage	12 volt (12V)
Nominal Output	0.8 kW
Direction of Rotation	Clockwise, viewed from pinion side

■ Trouble-shooting for starting motor

In case starting motor turns extremely slow or does not operate at all, the causes may be attributed to the followings.

- Defective battery
- Defective wiring
- Defective starting motor

The easy method to determine whether the starting motor or some other component is at fault is to turn on the headlights. That is, turn on the headlights while engine is stopped. If the lights stay dark, the battery is defective or contact of wiring and terminals is defective. (Of course, on the condition that headlights air unit is functioning properly.) In case the battery is barely operative due to defective charging system, be sure to clear up the cause and remove it, otherwise same troubles will not be ceased. (In case the battery is in the state fully charged.)

- (1) The headlights failed to light, contact of battery terminals is defective.
- (2) In cranking the engine, lights become extremely dim and revolution of starting motor slows down and stops.
  - Engine defective (Excess revolution resistance)
  - Armature shaft bent
  - Bearing bush worn out
  - Pole core screw loosened
 } Starting Motor will not operate
- Field coil grounded or layer insulation short circuited.
- Armature coil grounded or layer insulation short circuited.
- (3) Lights stay bright, but starting motor will not turn or turn slowly.
  - Contact of starting motor terminals defective.
  - Magnet switch defective (Coil disconnection, grounded, or layer insulation short circuited.)
  - Starter switch circuit contact defective
  - Brush contact pressure defective
  - Worn commutator

■ Precautions in handling starting motor

- (1) In installing starting motor, it should be securely fixed by tightening with close contact, other wise pinion gear will not engage with the ring gear properly, thereby causing breakage of the pinion gear and rear end plate. Sometimes starting motor will not operate.
- (2) In case the starting switch is on and the engine is turning but the engine will not start, check the fuel system for its cause.

- (3) In case the engine will not start, be sure not to keep turning the starting motor more than 30 seconds. The starting motor is designed to operate for short time running at rated capacity, accordingly long time operation of such motor may bring about such troubles that soldering on armature coils melts away or sticking of coils and lead wires by heating takes place. Furthermore, the battery will be remarkably discharged, making the motor doubly difficult in turning vigorously. In this circumstances, it is recommended to crank the engine for 10 seconds and then pause for 10 seconds one after the other.
- (4) In case the pinion gear will not engage with the ring gear on the fly-wheel and the motor makes racing, causing wear out on the tip of pinion gear, adjust the advance position of the pinion gear.

3.4 Glow Plugs

The glow plug is sheath type one and each cylinder is equipped with one glow plug in parallel, wiring for which is shown in the schematic.

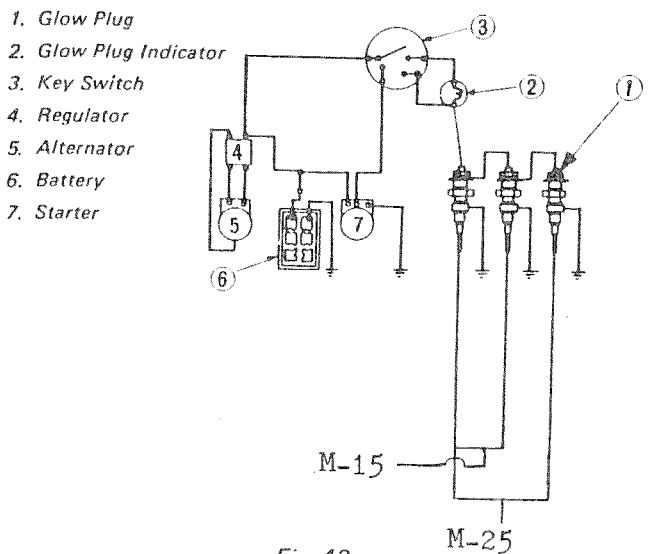

Fig. 43

■ Specifications of glow plug

	M-15	M-25
Quantity	2	3
Voltage & Current (per one plug)	7 amp. (7A) approx. (after 30 seconds at 10.5 volt) (10.5V)	7 amp. (7A) approx (after 30 seconds at 10.5 volt) (10.5V)

# 4. Reference Chart

## 4.1 Engine

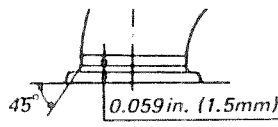
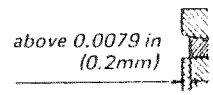
Parts	Items	Specifications	Standard Value	Maximum Limit	Remarks	
Cylinder Head	Cylinder head tightness	M-25	M9 x 1.25	43.4~46.99 ft.lbs. (6.0~6.5 kg-m)	When installing, apply a generous coat of engine oil onto the entire surface of each bolt.  	
		M-15	M8 x 1.25	31.09~34.7 ft.lbs. (4.3~4.8 kg-m)		
	Cylinder head surface distortion			0.002 in below (0.05mm below)		
	Intake/exhaust valve seat thickness	45°	0.059 in. (1.5mm)	0.0236~0.0314 in. (0.6~0.8 mm)		
	Top clearance					
Cylinder Liner	Standard ID				050 oversize liner ID	
	Piston clearance (At piston skirt)	M-15	2.6771~2.6779 in. (68.000~68.019mm)		2.683 in. (68.15mm)	2.6968~2.6976 in. (68.500~68.519mm)
		M-25	2.8346~2.8354 in. (72.000~72.019mm)		2.8405 in. (72.15mm)	2.8543~2.8550 in. (72.500~72.519mm)
	Type	Dry			Height above block surface ±0.00098 in. (±0.025mm)	
Piston	Standard OD				Oversize 0.020 in. (0.5mm)	
		M-15	2.677 in. (68mm)			
		M-25	2.8346 in. (72mm)			
	Piston-pin boss ID	0.7874~0.7879 in. (20.000~20.013mm)		0.7885 in. (20.03mm)		
	Piston-pin clearance		Interference Clearance 0.0004 in. 0.0004 in. (0.011mm) (0.011mm)			
Piston Ring	Ring gap	(top, 2nd)	0.0098~0.0158 in. (0.25~0.40mm)	0.0492 in. (1.25mm)	0.5 oversize top ring surface should be 0.0079 in. (0.2mm) below piston side surface.  	
		(oil ring)	0.0078~0.0158 in. (0.20~0.40mm)			
	Top ring width	Keystone type				
	2nd ring width	0.0574~0.0579 in. (1.458~1.470mm)	Ring groove clearance 0.0033~0.0044 in. (0.085~0.112mm)			
	Oil ring	0.1565~0.1571 in. (3.975~3.99mm)	0.0008~0.0020 in. (0.02~0.052mm)			
Piston Pin	OD	0.7874~0.7878 in. (20.002~20.011mm)				
	Pin-to-bush clearance		0.0006~0.0015 in. (0.014~0.038mm)	0.0059 in. (0.15mm)		

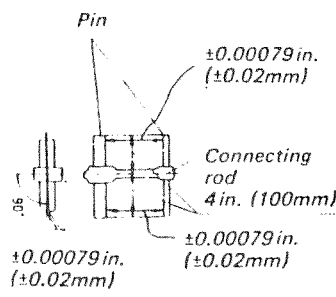

Parts	Items	Specifications	Standard Value	Maximum Limit	Remarks
Connecting Rod	Small end ID	0.8661~0.8670 in. (22.000~22.021mm) (without bush)			 <p>Pin</p> <p>±0.00079 in. (±0.02mm)</p> <p>Connecting rod 4 in. (100mm)</p> <p>±0.00079 in. (±0.02mm)</p> <p>±0.00079 in. (±0.02mm)</p>
	Small end width	0.8582~0.8622 in. (21.8~21.9mm)			
	Large end ID	1.5748~1.5756 in. (40.000~40.020mm) (without bush)			
	Large end width	0.8582~0.8622 in. (21.8~21.9mm)			
	Rod torsion (see diagram)		0.0008 in. (0.02mm)	0.002 in. (0.05mm)	
	Rod bolt torque	M7 x 0.75	19.527~22.42 ft.lbs. (2.7~3.1 kg-m)		
Crank-pin Metal	ID	1.4568~1.4587 in. (37.004~37.050mm) (with metal)			<p>Center thickness 0.0585~0.0590 in. (1.485~1.498mm)</p> <p>Crank arm-to-large end clearance</p>
	Width	0.6248~0.6350 in. (15.87~16.13mm)			
	OD	1.575 in. (40mm)			
	Running clearance		0.0011~0.0036 in. (0.029~0.091mm)	0.0059 in. (0.15mm)	
	Axial clearance		0.0078~0.0157 in. (0.2~0.4mm)		
Crankshaft Main Bearing	Crankshaft journal dia.	1.7296~1.730 in. (43.934~43.95mm)	Running clearance 0.0013~0.0036 in. (0.034~0.092mm)	0.0059 in. (0.15mm)	<p>When installing, apply a generous coat of engine oil onto the entire surface of each bolt.</p>
	Main bearing ID	1.7316~1.7333 in. (43.984~44.026mm) (with metal)			
	Crankshaft metal (2) width	0.7035~0.7138 in. (17.87~18.13mm)			
	Crankshaft journal dia.	1.7296~1.730 in. (43.934~43.95mm)	Running clearance 0.0013~0.00417 in. (0.034~0.106mm)	0.0059 in. (0.15mm)	
	Gear-side main bearing ID	1.7316~1.7338 in. (43.984~44.04mm) (with metal)			
	Crankshaft metal (1) width	0.7035~0.7138 in. (17.87~18.13mm)			
	Crankshaft metal (1) OD	1.8923~1.8933 in. (48.066~48.091mm)			
	Crank-pin journal dia.	1.455~1.4557 in. (36.959~36.975mm)		0.0047 in. (0.12mm)	
Crankshaft side clearance		0.0059~0.0122 in. (0.15~0.31mm)			
Crank bearing cap bolt (1) torque	M7 x 1.0	14.46~17.357 ft.lbs. (2~2.4 kg-m)			
Crank bearing cap bolt (2) torque	M8 x 1.25	21.7~25.3 ft.lbs. (3~3.5 kg-m)			

Parts	Items	Specifications	Standard Value	Maximum Limit	Remarks	
Cam Shaft	Cam bearing ID	1.299~1.30 in. (33.000~33.025mm)	Running clearance 0.0020~0.0036 in. (0.05~0.091mm)			
	Cam shaft dia.	1.2966~1.2972 in. (32.934~32.950mm)				
	Axial clearance		0.0028~0.0087 in. (0.07~0.22mm)			
	Cam lift	0.1968 in. (5mm)				
	Cam height	1.0582 in. (26.88mm)				
Timing Gear	Number of teeth, crank gear	25	-0.002~0.005 in. (0.0415~0.1154mm)	0.0118 in. (0.3mm)		
	Number of teeth, idle gear	69				
	Number of teeth, cam gear	50				
	Backlash					
Valve	Shrinkage	0.0354~0.0433 in. (0.9~1.1mm)			Valve guide bore should be reamed after inserted into cylinder head.	
	Face angle	45°				
	Intake bore	M-15				1.060~1.067 in. (26.9~27.1mm)
		M-25				1.2165~1.2244 in. (30.9~31.1mm)
	Exhaust bore	M-15				0.9212~0.9291 in. (23.4~23.6mm)
		M-25				1.0787~1.0866 in. (27.4~27.6mm)
	Stem dia.	0.2740~0.2746 in. (6.960~6.975mm)				
	Valve guide ID	0.2759~0.2765 in. (7.010~7.025mm)				
	Stem guide clearance					0.00137~0.00256 in. (0.035~0.065mm)
	Valve clearance					0.0057~0.0072 in. (0.145~0.185mm)
Valve Spring	Free length	1.3819~1.4016 in. (35.1~35.6mm)	16.54 lbs./1.2201 in. (7.5 kg/30.99mm)	3%	Load and length when installed.	
	Spring pressure					
	Perpendicularity					
	Spring pressure loss when installed					15%
Push Rod	Over-all length	A: 5.000 in. (127mm) B: 4.8543~4.870 in. (123.3~123.7mm)				
	Dia.	0.1968~0.2047 in. (5~5.2mm)				

Parts	Items	Specifications	Standard Value	Maximum Limit	Remarks
Valve Timing	Intake valve opened		At 20° BTDC		Model 15 & 25
	Intake valve closed		At 45° ABDC		
	Exhaust valve opened		At 50° BBDC		
	Exhaust valve closed		At 15° ATDC		
	Ignition process		1-2 1-2-3		
	Injection timing		25°~26° BTDC		
Oil Pump	Trochoid tooth width		0.7866~0.7874 in. (19.98~20.0mm)		Use Engine Oil CD (DS) Above 77°F (25°C), SAE 30  Between 32°F~77°F (0°C~25°C), SAE 20  Below 32°F (0°C), SAE 10W, 10W-30  Revolution of pump: 2000 rpm
	Outer rotor OD	1.5956~1.5968 in. (40.53~40.56mm)			
	Trochoid-to-body clearance		0.0027~0.0059 in. (0.070~0.150mm)		
	Trochoid-to-body side clearance		0.0031~0.0051 in. (0.080~0.130mm)		
	Oil pressure		64 psi (4.5 kgf/cm <sup>2</sup> )		
	Pump capacity		3.65 gal./min. (13.8ℓ/min.)		
Fuel Injection Pump	Model	Model 15 Model 25	NP-PFR2KD50/2NP3 NP-PFR3KD50/2NP4		Cam speed: 1500 rpm
	Injection pressure		1990 psi. (140kgf/cm <sup>2</sup> )		
	Pump plunger dia.		0.1968 in. (5mm)		
	Pump stroke		0.2756 in. (7mm)		
Injection Nozzle	Model		ND-DN12SD12		
	Injection pressure		1990~2133 psi. (140~150kgf/cm <sup>2</sup> )		
Cooling Water System	Cooling system	Natural circulation			With pressurized radiator
	Radiator cap pressure		12.8 psi (0.9kgf/cm <sup>2</sup> ) 17.0 psi (1.2kgf/cm <sup>2</sup> )		
	Fan belt length	FM 30 in. (762mm) in perimeter			
Battery	Model	12V 45AH			NS60
	Electrolyte specific gravity, discharge	1.120			
	Electrolyte specific gravity, charge	1.280 (68°F; 20°C)			
	Electrolyte specific gravity, over-discharge	1.30			
Dynamo	Voltage	12V			
	Current	8.5A			
	Check interval	Every 1000 service hours			

Parts	Items	Specifications	Standard Value	Maximum Limit	Remarks
Starter	Number of teeth, pinion	9			No failure at 500MV Insulation resistance Nominal value
	Number of teeth, ring gear	98			
	Insulation resistance				
	Check interval	Every 1000 service hours			
	Output	0.8kW			
Important Bolt Torque	Head set bolt and nut	M-25	M9 x 1.25	43.39~47.01 ft.lbs. (6~6.5 kgf-m)	Apply a generous coat of engine oil onto the entire surfaces of all important set bolts.
		M-15	M8 x 1.25	31.09~34.71 ft.lbs. (4.3~4.8 kg-m)	
	Flywheel fixing bolts	M10 x 1.25	40~43.38 ft.lbs. (5.5~6 kg-m)		
	Crankshaft main bearing set cap bolts	M8 x 1.25	21.70~25.31 ft.lbs. (3~3.5 kgf-m)		
	Crankshaft cap bolts	M7 x 1	14.47~17.36 ft.lbs. (2~2.4 kgf-m)		
	Rocker bracket set studs	M7 x 1	12.29~15.18 ft.lbs. (1.7~2.1 kgf-m)		
Rod bolts	M7 x 0.75	19.52~22.42 ft.lbs. (2.7~3.1 kgf-m)			
Bolt Torque	General set bolts and studs	M12		57.1~66.5 ft.lbs. (7.9~9.2 kgf-m)	All these torques are applied to those S43C bolts and studs which have relief number "7" or punch marks. 
		M10		35.4~41.2 ft.lbs. (4.9~5.7 kgf-m)	
		M8		17.4~20.3 ft.lbs. (2.4~2.8 kgf-m)	
		M6		7.2~8.3 ft.lbs. (1.0~1.15kgf-m)	

## Bolt Torques

Bolt material grades are shown by numbers punched on the bolt heads.  
Prior to tightening, be sure to check out the numbers as shown below:

ft-lbs. (kgf-m)

Material Grade (Punched No.) Nominal Dia.	Standard Bolt [None]		Special Bolt [7]		Special Bolt [9]	
	SS41, S20C		S43C, S48C (Refined)		SCR3, SCM3 (Refined)	
M 6	5.8 ~ 6.9	( 0.80 ~ 0.95)	7.2 ~ 8.3	( 1.00 ~ 1.15)	9.0 ~ 10.5	( 1.25 ~ 1.45)
M 8	13.0 ~ 15.2	( 1.80 ~ 2.10)	17.4 ~ 20.3	( 2.40 ~ 2.80)	21.7 ~ 25.3	( 3.00 ~ 3.50)
M10	28.9 ~ 33.3	( 4.00 ~ 4.60)	35.4 ~ 41.2	( 4.90 ~ 5.70)	44.8 ~ 52.1	( 6.20 ~ 7.20)
M12	46.3 ~ 53.5	( 6.40 ~ 7.40)	57.1 ~ 66.5	( 7.90 ~ 9.20)	75.9 ~ 86.8	(10.50 ~ 12.00)
M14	79.6 ~ 92.6	(11.00 ~ 12.80)	91.1 ~ 108.5	(12.60 ~ 15.00)	123.0 ~ 144.7	(17.00 ~ 20.00)
M16	123.0 ~ 141.0	(17.00 ~ 19.50)	144.7 ~ 166.4	(20.00 ~ 23.00)	191.7 ~ 224.2	(26.50 ~ 31.00)
M18	180.8 ~ 209.8	(25.00 ~ 29.00)	202.5 ~ 235.1	(28.00 ~ 32.50)	253.2 ~ 296.5	(35.00 ~ 41.00)
M20	245.9 ~ 289.3	(34.00 ~ 40.00)	271.2 ~ 318.2	(37.50 ~ 44.00)	361.6 ~ 419.5	(50.00 ~ 58.00)



**medalist**  
**Universal Motors**

Post Office Box 3008

OSHKOSH, WI 54903 • (414) 231-4100 • CABLE: UNIMOT • TLX 262-717