

Accessories For All Seaclos Heads

"FULL-WAY" SEACOX

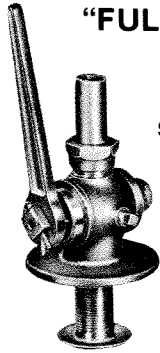

1507
For Inlets
Straight Tail Piece
Size 3/4 in.

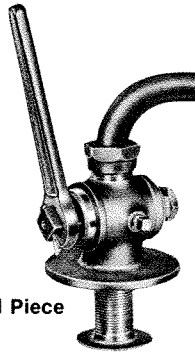

1511
For Outlets
90 Degree Curved Tail Piece
Size 1 1/2 in.

VENTED LOOP FOR TOILET WASTELINES

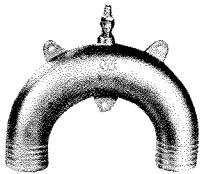

1548
For 1 1/2 in. I.D. Hose

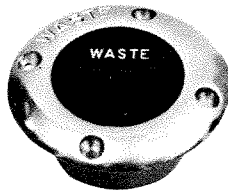

DECK PLATE
5323-H



REPAIR KITS



CLAMP
8669-L

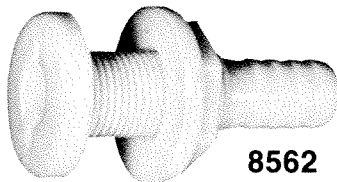

THRU-HULL FOR HOSE

8562

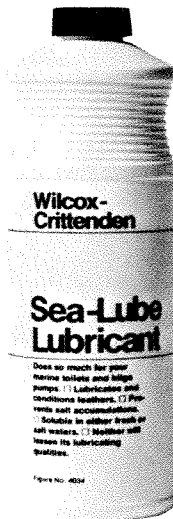

4034

WILCOX-CRITTENDEN

INSTALLATION & MAINTENANCE INSTRUCTIONS



"HEAD-MATE" Seaclos

INSTALLATION:

IT IS IMPERATIVE THAT THE U.S. COAST GUARD REGULATIONS REGARDING MARINE SANITATION SYSTEMS BE REFERRED TO BEFORE INSTALLATION OF THE W-C TOILET BEGINS. IT IS IN VIOLATION OF FEDERAL LAW TO DISCHARGE RAW SEWERAGE FROM ANY VESSEL INTO U.S. WATERS WITHIN THE 3 MILE LIMIT AFTER 1980. THIS TOILET MUST BE INSTALLED WITH A MARINE SANITATION DEVICE THAT MEETS THESE U.S. COAST GUARD REGULATIONS WITHIN THE TIME TABLE ESTABLISHED BY THE U.S. COAST GUARD.

W-C Seaclos may be installed either at or below the boat's waterline. The toilet must be securely fastened to prevent rocking during pumping, so it is best to bolt it to a board and screw the board to the cabin flooring to insure a solid mounting.

Hose may be used for piping and should be installed so as to avoid sharp bends. The flush water intake in the hull should be forward of and lower than the discharge outlet. A flap should be placed over the outside of discharge outlet to prevent gurgling.

On installations where the toilet may be below waterline a vented loop waste line is recommended. See Vented Loop, Figure 1548, for use with this toilet.

Use W-C "Full-Way" Seacox in thru-hull connections, Figure 1508, for the hull supply fitting, and Figures 1507 or 1511 for the hull discharge fitting. The inside diameter of the hose required for supply and discharge lines is noted under each fitting shown on the front cover of this folder. Hose is always measured by *inside diameter*. The tailpieces supplied on W-C Seaclos and Seacox will take hose with clamps. Preformed automobile radiator hose can sometimes be used to advantage.

G.W.

WILCOX-CRITTENDEN
A GULF + WESTERN MANUFACTURING COMPANY
MIDDLETOWN, CONNECTICUT 06457
Telephone 203-632-2600 — TWX 710-428-4097

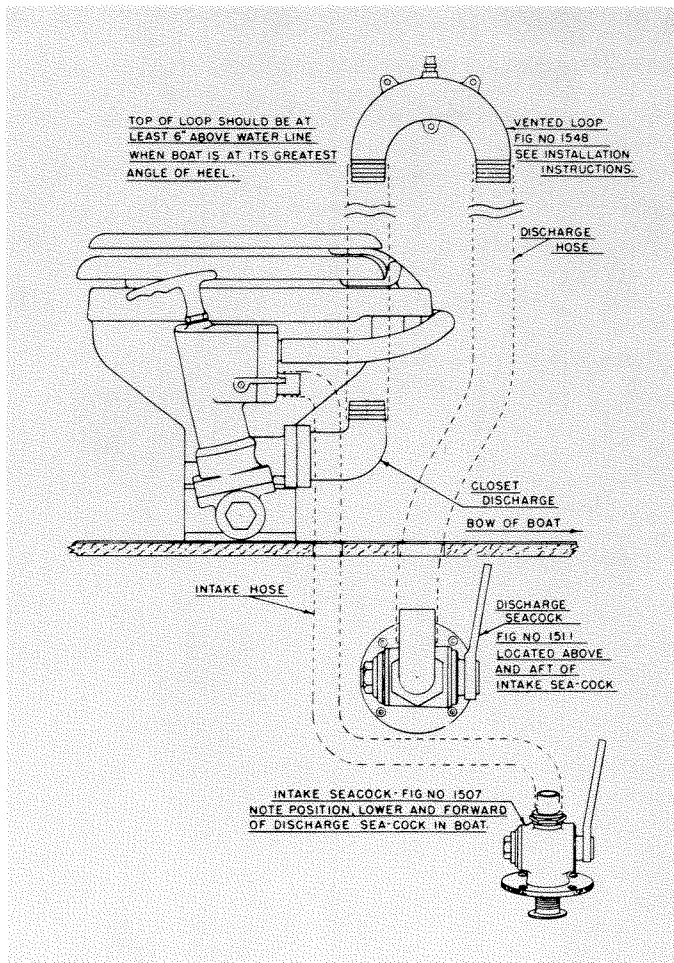

Where the toilet is set below the waterline, the W-C Vented Loop, Fig. 1548, should be installed in the discharge line, as shown in line drawing above. The bronze "U" loop has integral air vent which works automatically to prevent back syphoning into toilet, yet seals tightly so there is no possibility of leakage.

OPERATION:

An instruction plate is always furnished with each Seaclo. Be sure to place it where it will be *seen and read!* Your landlubber guests will appreciate proper instructions on the use of your toilet when they first come on board. You will save yourself considerable trouble if at the same time you emphasize that rags, bobby pins, paper towels, etc. should not be discarded in the toilet.

When a Seaclo is first placed in use, it may be necessary to put a pail of water into the bowl to prime the pump. This will not be required after the Seaclo has once been used.

The flush water supply valve is opened by raising the lever (Dwg. Ref. 15) on the side of the cylinder.

Before using the toilet, open the supply valve and pump some water into the bowl. After use, keep the supply valve open and pump slowly.

Once the bowl is clean, pump five or six extra strokes to thoroughly clear the discharge line of all refuse. Then close the supply valve and pump until the bowl is empty. When running in rough seas, or leaving the boat overnight, it is advisable to pump the bowl dry to prevent splashing. When the boat is unattended, it is advisable to close both sea cocks.

NORMAL CARE AND MAINTENANCE:

If your Seaclo works hard, check to *make sure* the sea cocks are wide open and that no kinks appear in the lines. Sometimes the sea cocks work shut with consequent restriction in the intake or discharge lines.

Some oil or grease on the piston rod and bearing pins in pump handle assembly makes for easier pumping. To reduce wear and maintain easy pumping operation, do not tighten the piston rod packing nut any more than necessary to prevent leakage around the rod. A little waterproof grease applied once a season to the packing found under this nut will do the trick.

If a foreign object becomes lodged in the toilet, remove the screws which hold the tail piece to which discharge pipe is attached and check the "Joker" valve. This is the spot where matches, bobby pins or similar items are likely to catch and cause trouble.

If pumping action becomes stiff and the above checks have been made, "Sea-Lube", a special water soluble lubricant, should be used. A few cups of "Sea-Lube" put into a dry bowl and pumped out of the bowl into the cylinder, but not overboard, will keep the unit working freely. A stroke or two is enough. Try to allow the "Sea-Lube" to stand for 24 hours.

HAUL-OUT

When you haul out for storage, certain steps should be taken to keep your Seaclo in first-class condition.

Fresh water should be allowed to stand in the pump for several days to dissolve the accumulation of salt in the cylinder and hose lines. Repeat this process, then pump dry. Remove drain plug in waste arm to drain any water which might remain. Replace drain plug and pour a few cupfuls of "Sea-Lube" into the bowl and pump the "Sea-Lube" out of the bowl into the bottom of the cylinder. A stroke or two is enough. Allow "Sea-Lube" to stand for 24 hours—pump dry and remove drain plug.

DO NOT PUT OIL, KEROSENE, GASOLINE OR ALCOHOL IN THE BOWL OR PUMP. THEY WILL RUIN THE VALVES.

If anti-freeze is used, it must be a glycol base.

COMMISSIONING INSTRUCTIONS

Replace drain plug in waste arm and use "Sea-Lube" as outlined in Haul-Out Instructions. Allow "Sea-Lube" to stand for 24 hours. If Haul-Out Instructions were followed, your Seaclo should be ready for use.

In the event your Seaclo is worn or has not had proper care, it is recommended that the pump unit be disassembled, the required new parts installed and the unit reassembled, with waterproof grease being applied to the piston leathers and cylinder wall. This greasing should be done whenever disassembly is required.

Be sure to check the "Joker" valve. If stiff, it should be replaced. Proper care will assure you of a long-lasting, free-working unit.

After boat is overboard it is good practice to make periodic checks on the waterlines, etc. to make certain that all connections are tight and that valves are functioning properly.

REPAIR PARTS

After considerable use, your Seaclo may require some repair parts. A handy W-C Repair Kit is available, containing all of the items you will probably need. Call for it by name. Be sure to use only W-C repair parts made for your model of toilet.

**"HEAD-MATE" REPAIR KIT
W-C FIG. 1520**

*These numbers in the Parts List indicate the items included in a standard "Head-Mate" Repair Kit. These new Parts are all items you will normally need to put your Seaclo in first-rate operating condition.

Keep a Repair Kit on hand at all times.

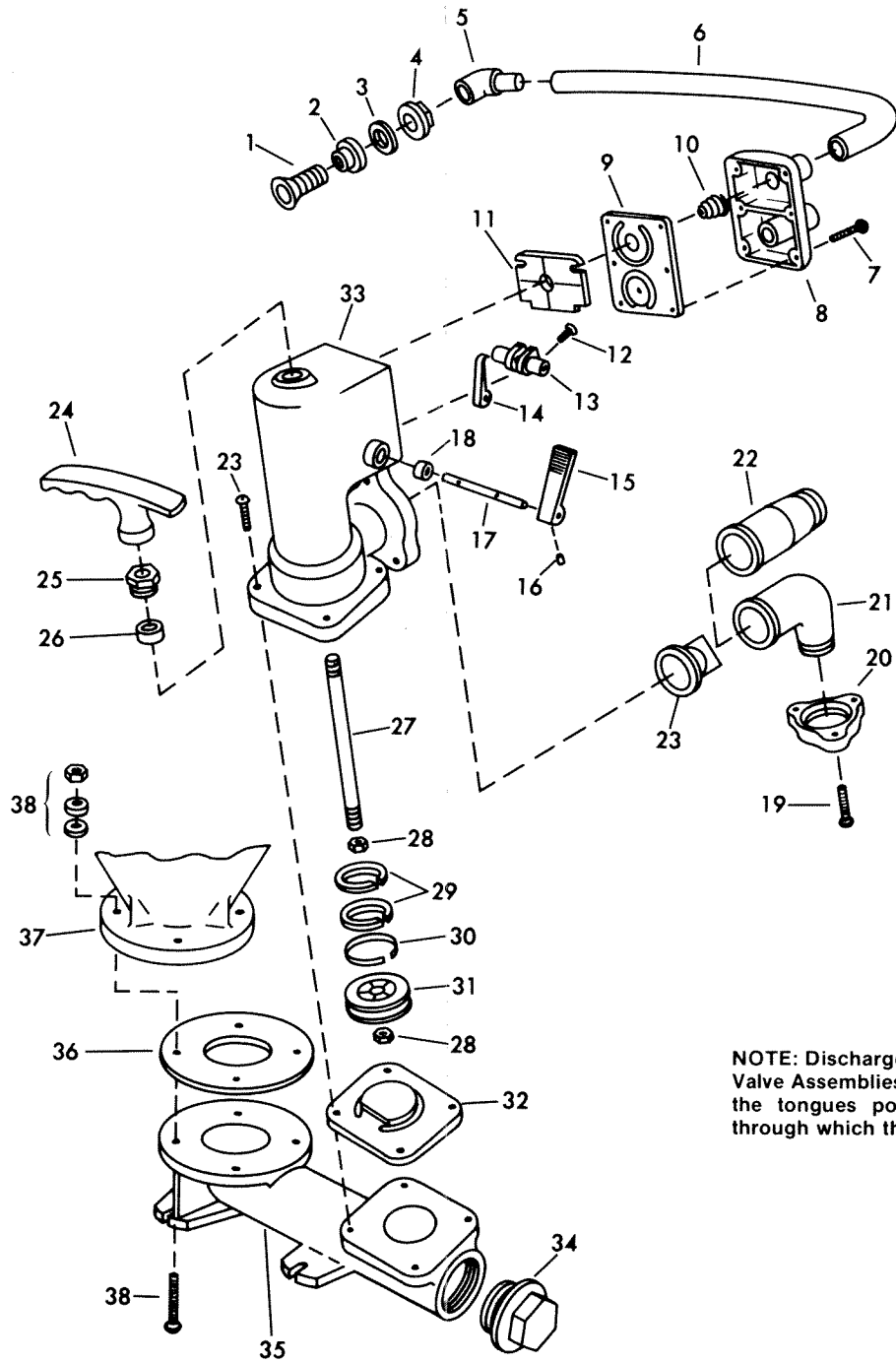

NOTE: Discharge Flap Valve and Inlet Flap Valve Assemblies must be installed so that the tongues point to the next opening through which the water will pass.

1460-C "Head-Mate" Seaclos Parts List

PART NO.	REF. NO.	DESCRIPTION	QUANTITY
015016	1	Bowl Spud	1
015065	2	Bowl Spud Rubber Gasket	1
015479	3	Bowl Spud Friction Washer	1
015024	4	Bowl Spud Nut	1
015032	5	Bowl Spud Elbow	1
015399	6	Inlet Flush Tubing, Vinylite	1
015255	7	Inlet Valve Cover Screw*	6
019596	8	{ Inlet Valve Cover	1
	9	{ Inlet Flap Valve*	1
015230	10	Inlet Flap Valve Spring	1
031005	11	Inlet Valve Plate	1
	12	{ Cam Shaft Screw*	2
	13	{ Inlet Valve Cam*	1
	14	{ Vacuum Breaker Finger*	1
019604	15	{ Inlet Water Lever	1
	16	{ Inlet Water Lever Screw*	1
	17	{ Inlet Water Lever Shaft	1
	18	{ Inlet Water Lever Seal*	1
015099	19	Coupling Flange Bolt	7
015396	20	Coupling Flange	1
015388	21	Discharge Tailpiece, 90-degree	1
015115	22	Discharge Tailpiece, Straight	1
013276	23	Backwater Check Valve (Joker)*	1
015347	24	Piston Rod Handle	1
015164	25	Piston Rod Packing Nut	1
015222	26	Piston Rod Packing*	1
015156	27	Piston Rod	1
015248	28	Piston Rod Retaining Nut	2
015198	29	Piston Ring	2
015206	30	Piston Ring Spring	1
015131	31	Piston	1
015008	32	Flap Valve*	1
015263	33	Cylinder	1
015017	34	Waste Arm Plug	1
015313	35	Waste Arm	1
015172	36	Bowl Gasket	1
015453	37	Bowl, complete with Bowl Spud Assembly	1
		{ Bowl Hold-Down Screw	4
015404	38	{ Bowl Hold-Down Washer, S.S.	4
		{ Bowl Hold-Down Washer, Rubber	4
		{ Bowl Hold-Down Nut	4
015305		Seat and Cover (Not Illustrated)	1
015461		Pump Assembly, Complete	1

*Parts supplied in Repair Kit Fig. 1520

In ordering parts be sure to specify: Model, Part Number, and Description of Parts.