

**SWAGING TOOLS  
USE AND ADJUSTMENT INSTRUCTIONS  
 FOR  
 82632-HAND AND S2632-BENCH**

Our line of "New Generation" swaging tools have been designed to compress Aluminum and Copper Oval and stop sleeves onto mechanical cables in the sizes of 1/16", 3/32", 1/8, 5/32" and 3/16". A description of the two models is as follows:

**MODEL #      DESCRIPTION**

- S2632-H      Hand held tool. The length of the handles assures ease of operation, and the unique box joint at the pivot point of the swaging jaw keeps the swaging surfaces in line with each other.
- S2632-B      Bench mounted tool. This tool utilizes the, same swaging head as the hand model above. The toggle action assures ease of operation, leaving one hand free to manipulate the cable.

**CABLE, SLEEVE, TOOL/GAUGE CAVITY SELECTION CHART**

Aluminium / Copper Oval Sleeves		Cable & Sleeve Size	Aluminium / Copper Stop Sleeves	
Groove & Gauge Cavity	Number of Crimps		Groove & Gauge Cavity	Number of Crimps
2	1	1/16"	2	1 overlapped
3	3	3/32"	3	2 overlapped
4	3	1/8"	3	2 overlapped
5	3	5/32"	4	2 overlapped
6	4	3/16"	4	2 overlapped

**IMPORTANT NOTE**

FITTINGS PRESSED OR SWAGED OVER ANY PLASTIC JACKET WILL NOT HOLD TO THE NOMINAL PUBL

## ADJUSTMENT INSTRUCTIONS

Model S2632H (Hand Tool): Screw A sets the preload and is the primary pressure adjustment. Screw B is a locking screw and must be loosened before Screw A can be turned.

To adjust: Turn Screw B counter-clockwise to loosen. Two or three turns will usually free the adjusting bar. Turn Screw A clockwise to increase pressure. A good starting point for checking the proper pressure on the tool is by measuring the handle spacing (14 1/4"). Measure the distance indicated from the outside bottom edges of the grips when the end of the tool at cavity #2 is touching but not closed (not under tension). Retighten Screw B to lock at the desired pressure.

Model S2632B (Bench Tool): Raise handle to relieve pressure on the jaws. Loosen Locking Nut (1). Insert a pin or the tip of an Allen Wrench in the hole on the Cam (2). Loosen Screw (3). Raising the pin in the Cam (2) will increase pressure on the jaws. A starting point for proper adjustment is to measure the height of the handle tip from the bench top. When the end of the jaws at cavity #2 are touching but the handle is not closed under tension, the measurement should be 8 5/8" to 9 1/8". After proper cam position is found, tighten Screw (3) while holding Cam (2) in position. Then tighten Lock Nut (1).

JNS

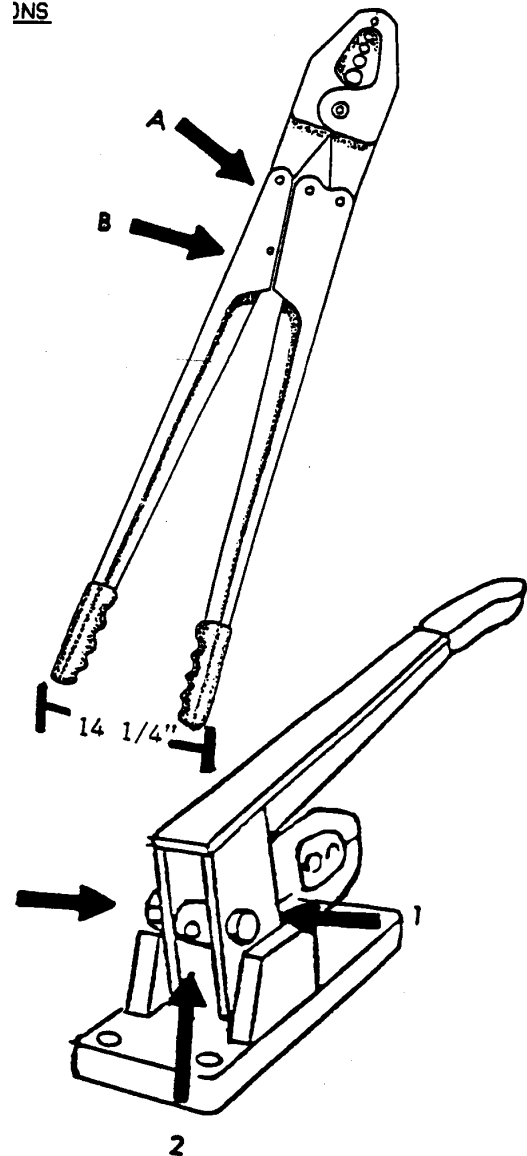

**HANDLES ARE UNDER TENSION - GRIP FIRMLY WHEN OPENING.**

NOTE: For long life and ease of operation, these swaging tools must be kept well lubricated, maintained and in proper adjustment. For lubricating purposes, a light motor oil is satisfactory.

WARNING: The holding power of sleeves is influenced by the diameter of the wire rope as well as construction. Exact strength tests should always be performed on a sample of the wire rope to be used when exact holding power must be determined. As in all wire rope applications, proper design factor must be employed: design factor is the ratio of strength of assembly to the applied load.

## MAKING A COMPRESSION SLEEVE SPLICE

Compression Sleeves are usually used in three types of splices: Loop, Lap or Stop Sleeve (see below). After determining which nominal diameter wire rope you wish to splice and the type of splice you wish to make, select the Oval or Stop Sleeves of the same nominal size. Then, by referring to the Chart on page (1) note which tool, tool groove/gauge cavity you should use and the number of crimps which should be taken. Proceed as follows:

**LOOPS:** Insert cable through the sleeve and rethread back to form loop to size desired. It is usually easier to form a larger loop at first and then to pull back on the longer end of the cable until the proper loop size is obtained. Leave about 1/8" of cable extending outside of the sleeve after threading, and make sure this does not slip back into the sleeve when "pulling up". Using the correct groove #, take the required number of crimps along the sleeve. Do not start on the very edge of the sleeve. Sleeve ends should project beyond the tool jaws slightly. After each crimp, rotate the sleeve 180°. This will help prevent the sleeve from becoming "banana" shaped. Gauge the sleeve after compression. If the gauge does not slip freely onto the crimp portion, the tool should be adjusted. See "Adjustment Instructions".

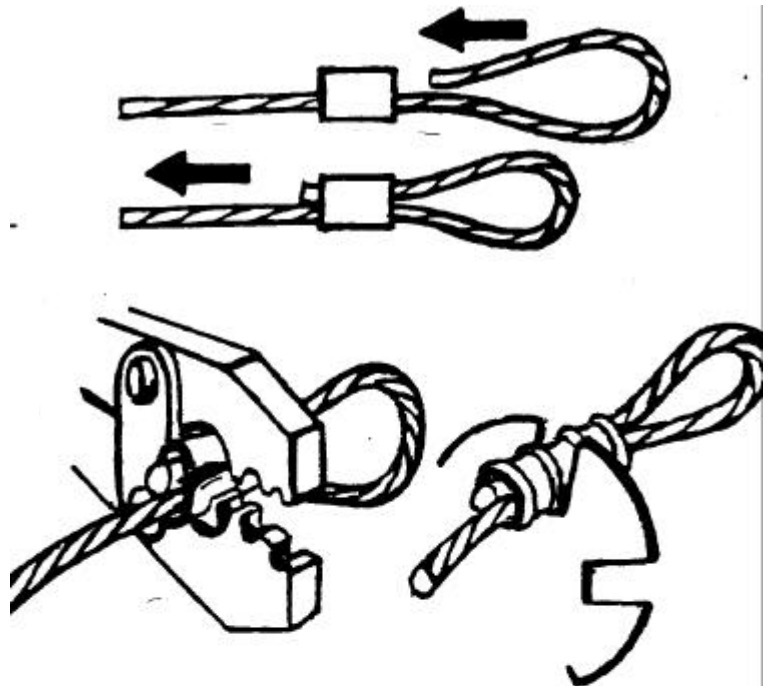

**LAP SPLICE:** After threading the two lengths of cable into the Oval Sleeve, crimping instructions are basically the same as loops. Note, a minimum of two sleeves are recommended and proper tests should be made to determine actual strength of the splice. Leave the usual 1/8" of cable protruding from the sleeve and allow a space of at least two cable diameters between the sleeves. Gauge as usual.



**STOP SLEEVE:** Thread cable through sleeve until a full 1/8" of cable is protruding from the stop. Crimp the sleeve the recommended number of times in the groove, indicated in the chart. Stop Sleeves will not hold for the break strength of the cable. Proof testing is recommended for specific applications. Gauge as usual.



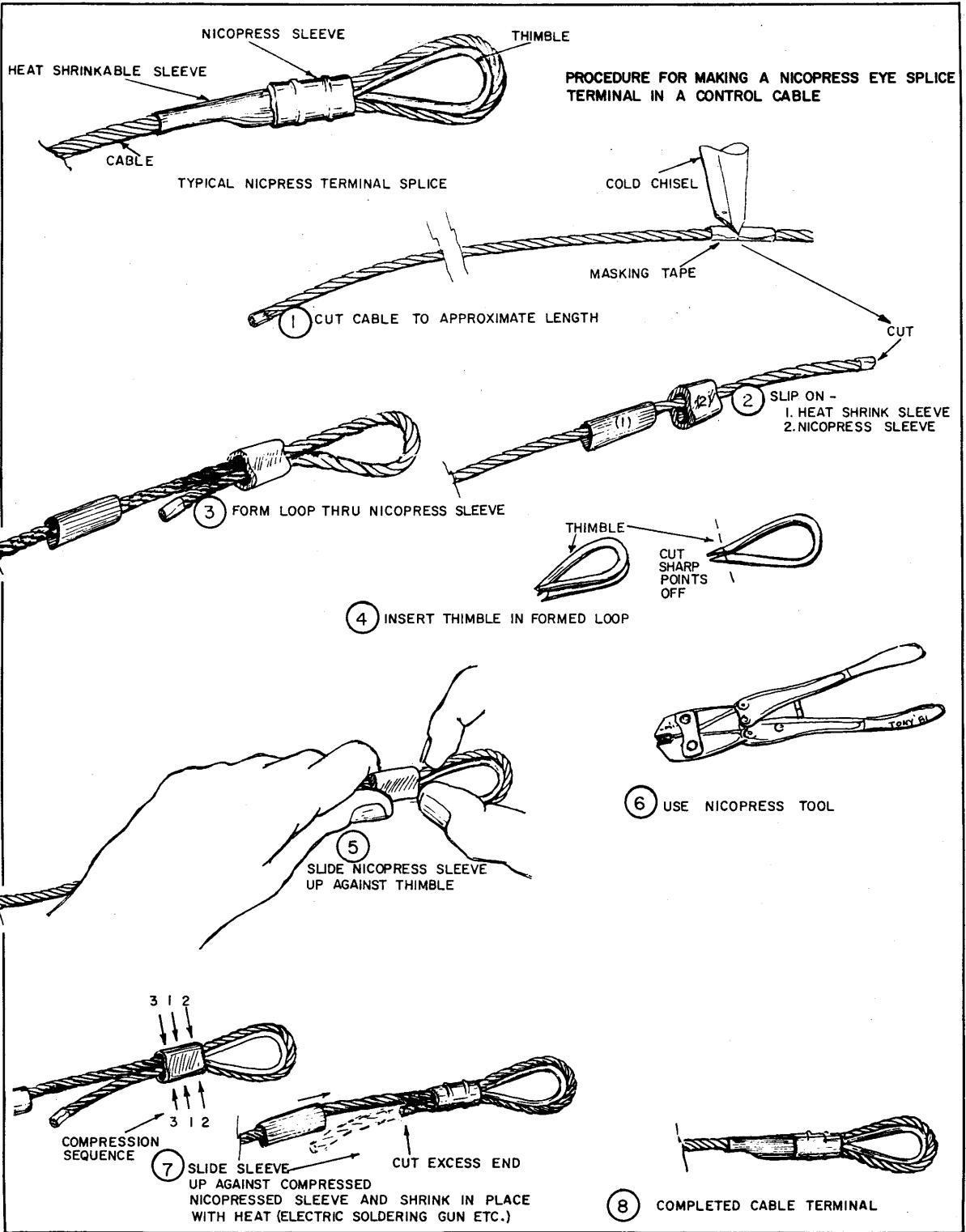

## Aircraft Control Cables

### 1x 19 Non Flexible Cable

One strand of 19 wires. It has more metallic area than 7 x 7 or 7 x 19 cable which makes it the strongest but also the least flexible. Generally used for bracing purposes. Can be used for controls. Made to MIL-C-6940 (galvanized) and MIL-C-5693 (stainless).

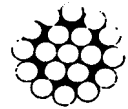

### 7 x 7 Flexible Control Cable

Seven Strands of seven wires each. Used for control purposes where extreme flexibility is not required, but where abrasion is a factor. Made to MIL-W-1511 (galvanized) and MIL-C-5424 (stainless).



### 7 x 19 Extra Flexible Control Cable

Seven strands of 19 wires each. Its greater metallic area makes it stronger than 7 x 7 cable. Because of its fine wires, the best service is obtained with 7 x 19 wire where abrasion is not too severe. These same fine wires, however make it the most flexible to meet severe bending. Made to MIL-W-1511 (galvanized) and MIL-W-5424 (stainless).



Galvanised Control Cable			
Cable Dia.	Break Strength	Weight / 100ft	Part Number
1/8	2100lb	3.5lb	1/8x1x19-GV
1/16	480lb	0.75lb	1/16x7x7-GV
3/32	920lb	1.6lb	3/32x7x7-GV
1/8	1700lb	2.8lb	1/8x7x7-GV
3/32	1000lb	1.74lb	3/32x7x19-GV
1/8	2000lb	2.9lb	1/8x7x19-GV
5/32	2800lb	4.5lb	5/32x7x19-GV
1/4	7000lb	11.0lb	1/4x7x19-GV

Stainless Control Cable			
Cable Dia.	Break Strength	Weight / 100ft	Part Number
1/8	2100lb	3.5lb	1/8x1x19-SS
1/16	480lb	0.75lb	1/16x7x7-SS
3/32	920lb	1.6lb	3/32x7x7-SS
1/8	1700lb	2.8lb	1/8x7x7-SS
3/32	920lb	1.74lb	3/32x7x19-SS
1/8	1760lb	2.9lb	1/8x7x19-SS
5/32	2400lb	4.5lb	5/32x7x19-SS
3/16	3700lb	6.5lb	3/16x7x19-SS
1/4	6400lb	11.0lb	1/4x7x19-SS

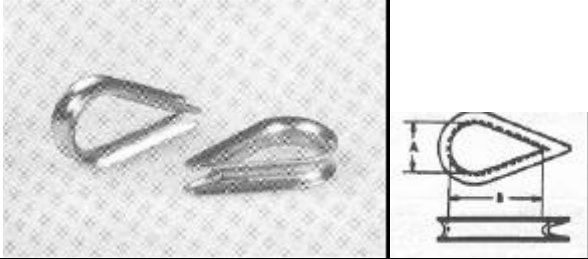
<b>AN100 Thimbles</b> Available in cadmium-plated steel or in corrosion resisting steel. Thimbles are made in conformance with MIL-T-5677 and standard drawing AN100. When ordering thimbles use AN number plus dash number for thimble desired.	Fits Cable Size	Dimension		Carbon Part No.	Corr.Res. Part No.
		A	B		
	1/16-5/64	.35	.70	AN100-3	AN100-C3
	3/32-7/64-1/8	.35	.70	AN100-4	AN100-C4
	5/32	.40	.80	AN100-5	AN100-C5
	3/16	.50	1.00	AN100-6	AN100-C6
	1/4	.70	1.40	AN100-8	AN100-C8

<b>Nicopress Oval Sleeves</b> Use zinc with stainless cable, copper with galvanized cable.	Cable Size	Copper Part No.	Zinc Part No.
	1/16	18-1-C	28-1-C
	3/32	18-2-G	28-2-G
	1/8	18-3-M	28-3-M
	5/32	18-4-P	28-4-P
	3/16	18-6-X	28-6-X
	1/4	18-10-F6	

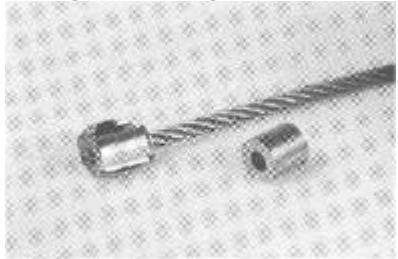
<b>Nicopress Stop Sleeves</b> 	Cable Size	Part No.
	1/16	871-1-C
	3/32	871-17-J
	1/8	871-18-J
	5/32	871-19-M