



HUNTER®

MARINE CORPORATION

AN EMPLOYEE OWNERSHIP COMPANY

We Go The Distance

*Operator's
Manual
Hunter 50cc*

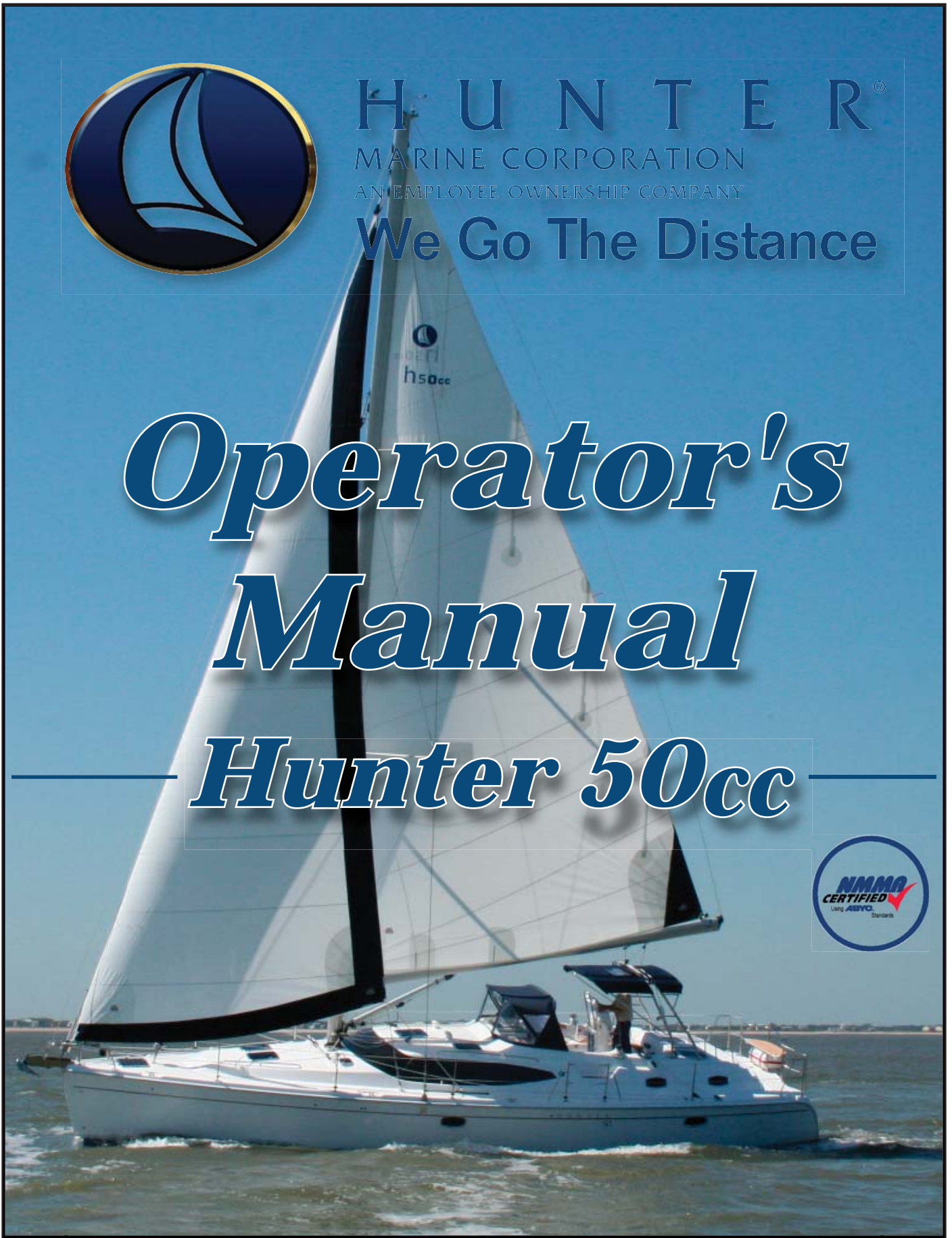

Thank You!
From the General Manager

Dear Hunter Owner,

Congratulations and welcome to the Hunter family! As a Hunter owner, you will enjoy the quality and the attention to detail for which Hunter Boats are renowned. Hunter and your dealer are committed to your service and total satisfaction.

This Operator's Manual will acquaint you with the proper operation and maintenance of your new Hunter boat, as well as boating safety, which is our primary concern, whether in ports or at sea.

The new boat warranty registration form you signed at the time of delivery will be sent to us by your dealer. This registers the one year warranty and establishes your contact information in our system. It will also activate Hunter's Customer Satisfaction program (CSS), our effort to insure the highest level of satisfaction and enjoyment with your new Hunter. Within a few weeks of delivery you will receive a letter asking you to complete an online questionnaire primarily about your experience with the dealer. Several months later you will receive a second letter asking you to evaluate the boat. We value your opinion and hope that you will take the time to complete both surveys.

As you already know, we work with the highest quality equipment manufacturers to supply the components for your boat. To receive full warranty coverage on all the individual components, such as engine, electronics and appliances, be sure to complete and return to the Original Equipment Manufacturers (OEM) warranty cards to activate the individual warranties for these important components. You will find them in the owner's packet that also contains the OEM manuals for this equipment. Please remember all the information contained in the OEM manuals supersedes the information contained in this manual.

Finally, if you are new to boating, be certain to learn the proper rules of seamanship to ensure the safety of your passengers. Refer to Chapman's Piloting, Seamanship, and Small Boat Handling Manual for important and useful information concerning this aspect of boating. Attend a safe boating course offered by the United States Coast Guard Auxiliary, United States Power Squadron, or any enterprise experienced in conducting safe boating courses.

Thank you for choosing Hunter. I am confident your new boat will provide you and your family with years of enjoyable boating.

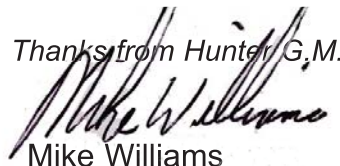
Thanks from Hunter, G.M.

Mike Williams
General Manager

As the owner of a Hunter 50cc, you have chosen one of the finest boats money can buy.

Hunter Corporation, is one of America's oldest privately held boating companies. In February 1996 Hunter became an employee ownership company. We continue to be dedicated to giving you a quality boat that will bring you years of enjoyment whether you're spending a day at the marina or cruising down a waterway. Performance, dependability, safety, and comfort is more than just a catchy phrase at Hunter. It is the basis for every step of design and construction to assure you of many pleasure-filled years of boating.

A Proud Heritage

With every Hunter, three generations of experience combine with modern engineering and production techniques provide you one of the most affordable, full featured fishing boats in the industry today.

From the stem to the stern, every piece of equipment and its placement has been engineered to provide the most seasoned sailer with the best advantage on the water. Hunter has included everything to make ours the most complete sailing vessel on the market today.

How to Use this Manual

Many people read their operator's manual from beginning to end when they first receive their new boat. If you do this, it will help you learn about the features and controls for your new boat. In this manual, you'll find that pictures and words work together to explain things quickly.

Table of Contents

A good place to look for what you need is in the Table of Contents in the beginning of this manual. It is a list of the chapters and the page number where you'll find them.

Safety Warnings and Symbols

In Boating Safety section you will find a number of cautions, warnings, and danger symbols to tell you about things that could hurt you.

In this chapter we tell you where the hazards are. Then we tell you what to do to help avoid or reduce them. Please read this chapter carefully, to prevent yourself or someone else from possible injury.

Any questions regarding your Hunter ® or this manual contact Customer Service at:

Hunter Corporation
Route 441, Post Office Box 1030
Alachua, FL. USA 32616
Phone: (386) 462-3077
Fax: (386) 462-4077
e-mail: customerservice@huntermarine.com
(8am to 5pm EST) 1-800-771-5556

Operator's Manual at a Glance

- 
1. Introduction
 2. Documents and Forms
 3. Warranty
 4. Boating Safety
 5. Fuel System
 6. Underwater Gear
 7. DC Electric Systems
 8. AC Electric Systems
 9. Water Systems
 10. Sanitation and Waste Systems
 11. Engines and Transmissions
 12. Sails and Rigging
 13. Getting Underway
 14. Maintenance
 15. Glossary

How do I prevent Carbon Monoxide buildup? pg.4.8
How do I fuel my boat? pg. 5.6
How do I drain water from my fuel filters? pg. 5.7
How do I remove my battery? pg. 7.3
How do I connect shore power? pg.8.5
How do I disconnect the shore power? pg. 8.5

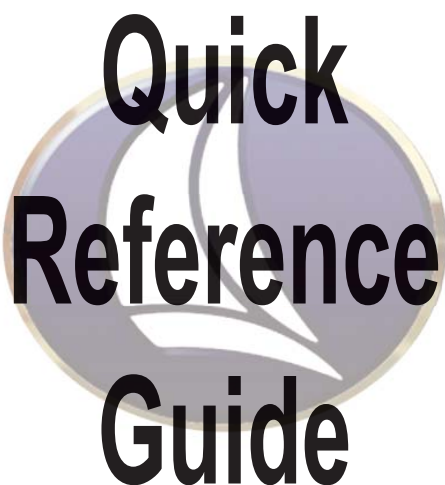

Quick Reference Guide

How do I start my generator power? pg. 8.6
How do I shut down my generator? pg. 8.6
How do I operate my air conditioning? pg. 8.6
How do I fill my fresh water tank? pg. 9.2
How do I sanitize my water? 9.3
How do I connect dockside water? pg. 9.2
How do my bilge pumps work? . pg. 10.3

How do I run my macerator pump? pg. 10.6
How do I start my engines? pg. 13.3
What to do in case of a fire. pg. 4.12
Fixing scratches pg. 14.3
Periodic maintenance. pg. 14.11
Winterization pg. 14.8
Lifting and Storing your boat pg. 14.7

Table of Contents

1. Introduction	1.1	5.1 Fuels Tanks	5.3
1.1 The Manual Packet	1.2	5.2 Fuel Supply Lines and Hoses	5.4
1.2 Your Responsibilities	1.2	5.3 Fuel Valves	5.5
1.3 Dealers Responsibilities	1.3	5.4 Fuel Filters	5.5
1.4 Sources of Information	1.3	Fuel Filter Reference	5.7
1.5 Equipment Manufacturer Manuals	1.4	5.5 LPG	5.8
1.6 Warranties	1.4	Troubleshooting	5.10
1.7 Hull Identification Number	1.4	Engine Fuel System Illustration	5.13
1.8 Manufacturers Certifications	1.4	Generator Fuel System Illustration	5.14
1.9 Service Parts and Repair	1.5		
2. Forms	2.1	6. Underwater Gear	6.1
Documents and Forms Overview	2.2	6.1 Mechanical Propulsion Components	6.2
Out of Water Inspection	2.3	6.2 Steering	6.3
In Water Inspection	2.6	6.3 Seawater Pickup	6.4
Pre-Departure Checklist	2.7	6.4 Windlass and Anchoring	6.5
After Sailing Checklist	2.8	6.5 Bow Thruster Option	6.7
Pre-Delivery Service record	2.9	6.6 Emergency Tiller System	6.7
Float Plan	2.10	6.7 Back-up Rudder System (Option)	6.8
Maintenance Log	2.11	Bilge Through Hull Illustration	6.9
		Port Sheer Through Hull Illustration	6.9
		Starboard Sheer Through Hull Illustration	6.10
3. Warranty	3.1	7. DC Electric	7.1
Warranty Information	3.2	7.1 The DC Electrical System	7.2
Owner Information Card	3.4	7.2 Systems and Components	7.5
Restrictions to Warranties	3.5	7.3 Operations and Maintenance	7.8
Warranty Registration	3.6	Troubleshooting	7.10
Sample Form Letter	3.7	Basic Power Supply System Layout	7.11
		DC Control Panel	7.12
4. Boating Safety	4.1	8. AC Electric	8.1
4.1 Safety	4.2	8.1 Power Supply Components	8.2
4.2 Carbon Monoxide Hazard	4.4	8.2 Systems and Components	8.4
4.3 Other Dangers	4.10	8.3 Operations and Maintenance	8.5
4.4 Fire	4.12	Troubleshooting	8.9
4.5 Distress Signals	4.12		
Lightning Illustration	4.15	9. Water Systems	9.1
Dimensions and Capacities	4.16	9.1 Dockside Water Supply	9.2
Deck Hardware Arrangement	4.17	9.2 Water Tanks	9.2
Deck Hardware List	4.18	9.3 Pumps	9.4
Interior Arrangement	4.22	9.4 Pickups and Strainers	9.5
		Water Manifold Legend	9.7
5. Fuel System	5.1		
Fuel Safety Checklist	5.2		

Troubleshooting	9.8	Mainsheet Purchase Layout	12.14
Fresh Water Arrangement	9.9	Standard Running Rigging	12.15
Fresh Water Tank Arrangement	9.10	Furling Running Rigging	12.16
Galley Water Manifold Arrangement	9.11	Overlapping Jib Self-tacking Details	12.17
A/C Plumbing Arrangement(Raw Water)	9.12	Jib Furling Line Layout	12.18
		Mainsheet Traveler and Dual Manisheet Arrangement	12.19
10. Sanitary Systems	10.1	Standard and Furling Sailplan	12.20
10.1 Drains and Discharges	10.2	Tall Rig Standard and Fuling Sailplan	12.21
10.2 Pumps	10.3	Lazyjack Installation	12.22
10.3 Other Waste Related	10.5	Sail Cover Installation	12.23
10.4 Head System	10.5	Optional Spinnaker Layout	12.24
10.5 Operations and Maintenance	10.6		
Troubleshooting	10.9	13. Getting Underway	13.1
Black Water System	10.10	13.1 Boarding Your Boat	13.2
Black Water System W/Overboard	10.11	13.2 Starting the Engine	13.3
Grey Water System	10.12	13.3 Getting Underway	13.4
Gray Water System (Bilge Water)	10.13	13.4 Returning to Port	13.6
		13.5 Emergency Operations	13.6
11. Engines and Transmissions	11.1		
11.1 Engines	11.2	14. Maintenance	14.1
11.2 Transmissions	11.4	14.1 Maintenance Materials	14.2
11.3 Operations and Maintenance	11.4	14.2 Exterior	14.2
Troubleshooting	11.6	14.3 Interior	14.4
Exhaust System Arrangement	11.9	14.4 Mechanical Systems	14.4
		14.5 Periodic Maintenance	14.6
12. Sails and Rigging	12.1	14.6 Lifting and Storage	14.7
12.1 Main Rig Components	12.2	14.7 Fitting out after Storage	14.9
12.2 The Mast	12.2	14.8 Stuffgin Box (SureSeal)	14.10
12.3 The Boom	12.3	14.9 Castiron Keel Maintenance	14.10
12.4 The Sails	12.3		
12.5 Reefing Instructions	12.3	15. Glossary	15.1
12.6 Reefing Procedure	12.3		
12.7 Shaking out a Reef	12.3		
12.8 Spinnaker (Option)	12.3		
12.9 Roller Furling System	12.4		
12.10 The Arch	12.5		
12.10 Protecting Your Rigging	12.5		
Standard Standing Rigging	12.7		
Standard Furling Standing Rigging	12.8		
Standing Rigging Details	12.9		
Furling Running Rigging Arrangement	12.10		
Reefing and Rope Vang Arrangement	12.11		
Fitting Rodkicker Gas Cylinder	12.12		
Rodkicker and Boom Vang Details	12.13		



H U N T E R[®]

MARINE CORPORATION

AN EMPLOYEE OWNERSHIP COMPANY

We Go The Distance

Chapter 1

Introduction

Hunter 50cc



1.1 The manual packet

This operator's manual, along with your owner's packet, has been compiled to help you to operate your boat with safety and pleasure. The Owner's / Operator's Manual:

- Describes basic safety information;
- Describes some of the features of your boat;
- Describes the equipment on your boat;
- Contains fundamentals of the use of that equipment;
- Contains fundamentals of the use of your boat.

However, please note that the information in this manual only summarizes more detailed information in the equipment manuals. The summaries are intended to be a convenient reference for daily use. OEM manuals take precedence over the information in the manufactures documents.

This information does not give you a course in boating safety, or how to navigate, anchor, or dock your boat. Operating a boat, sail or power, requires more skills, knowledge and awareness than is necessary to operate a car or truck.

1.2 Your Responsibilities

Please keep this manual in a dry and secure but readily accessible place and leave it on the boat at all times! Make sure to hand over this manual to the new owner if you decide to sell the boat.

If this is your first boat of this type or you are changing to a new boat you are not familiar with, please insure that you obtain handling and operating experience before assuming command. For your safety, and the safety of your passengers you must:

- Take a course in Boating Safety;
- Get instruction, or aide in the safe and proper handling of your boat;
- Familiarize yourself and your passengers of the locations, and use of all safety, and essential operating equipment.

Understand and follow the rules of the road;

- Learn how to navigate a boat in the proper sea, and weather conditions;
- Register your boat, contact state boating authorities, or the marine dealer for the registration requirements.

Boating Safety courses provide owners and operators with the opportunity to gain knowledge and experience in a variety of skills:

- Navigation
- Seamanship and boat handling
- Rules of the Road
- Knowledge of federal, state, and local regulations
- Weather prediction
- Safety at sea
- Survival in bad weather
- Respect for others on the water
- First aid
- Radio communication
- Distress signals
- Rendering assistance to others
- Use of lifesaving equipment
- Pollution control
- Knowledge of the boat and its systems
- Seaworthiness
- Leaving or approaching a dock mooring
- Anchoring and weighing anchor
- Beaching the boat and shallow water operations
- Towing and being towed
- Handling mooring lines and tying up
- Procedures for emergencies including fire, flooding, collision, and medical emergencies, etc.

Even when your boat is categorized for them, the sea and wind conditions corresponding to the design categories A, B, or C (see the design category example at the end of this section.) can range from strong gale to severe conditions where only a competent, fit and trained crew handling a well maintained boat can safely operate.

We would like to hear your comments or suggestions concerning our manuals. Did you find the information helpful? Was the information delivered in a clear precise manner? Was the information thorough enough to help you with your new boat? Please call us at (904) 827-2055 to speak to our Manual Department, if you have questions, or comments, concerning the manual. Please note, this department does not have design or warranty information you will need to contact those departments for such information.

Fig. 1.1 Design Categories

Sea and wind conditions for which a boat is assessed by the International Standard to be suitable, provided the craft is correctly handled in the sense of good seamanship and operated at a speed appropriate to the prevailing sea state.

Design Category A (“ocean”)

Category of boats considered suitable to operate in seas with significant wave heights above 4 m and wind speeds in excess of Beaufort Force 8, but excluding abnormal conditions, e.g. hurricanes.

Design Category B (“coastal”)

Category of boats considered suitable to operate in seas with significant wave heights up to 4 m and winds of Beaufort Force 8 or less

Design Category C (“inshore”)

Category of boats considered suitable to operate in seas with significant wave heights up to 2 m and a typical steady wind force of Beaufort Force 6 or less.

Design Category D (“sheltered waters”)

Category of boats considered suitable to operate in waters with significant wave heights up to and including 0,30 m with occasional waves of 0,5 m height, for example from passing vessels, and a typical steady wind force of Beaufort 4 or less.

REF: EN ISO 12217

An orientation in the general operation and mechanical systems of your boat;

An explanation of the Hunter CSI Program and Hot Alert process for same.

A copy of the Product Delivery Service Record form” completed by you and the dealer during your inspection of the boat;

A review of all warranty information and how to obtain warranty service;

The complete Owner’s Packet.

If you do not receive these materials, forms, or information, or you have any questions contact your dealer, or call 1-800-771-5556

1.4 Sources of Information

In North America, contact one of the following for Boating courses:

- U.S. Coast Guard Auxiliary
- U.S. Power Squadron
- Canadian Power and Sail Squadrons
- Red Cross
- State Boating Offices
- Yacht Clubs

Contact your dealer or the Boat/U.S. Foundation at 1-800-336-2628

Outside of North America, contact your boat dealer, or your government boating agency for assistance.

Hunter supplies you with; and recommends that you read the following:

Piloting, Seamanship and Small Yacht Handling (Chapman)
Motor Yacht and Sailing
P.O. Box 2319, FDR Station
New York , NY 10002

1.3 Dealer's Responsibilities

In addition to a pre-delivery check and service of your boat, your dealer should give to you:

A description and demonstration of the safety systems, features, instruments, and controls of your boat;

Hunter recommends that you purchase and read the following:

Yachtsman Handbook
by Tom Bottomly
Motor Yacht and Sailing
P.O. Box 2319, FDR Station
New York, NY 10002

The Complete Book of Maintenance and Repair
by Dave Kendall
Doubleday and Co.
Garden City, NY 11530

Pleasure Yachting and Seamanship
U.S. Coast Guard Auxiliary
306 Wilson Road Oaklands
Newark, DE 19711

1.5 Equipment Manufacturer Manuals

Hunter purchased various equipment and components from other manufacturers and installed them on your boat while it was being built. Examples include the engines, pumps, and the generator. Most OEMs (Original Equipment Manufacturers) have provided operation and maintenance manuals for your boat's equipment. Keep OEM manuals with your Hunter Operator's Manual in a safe and accessible place. Be sure to pass them along to the new owner if you sell your boat.

NOTE: The OEM manuals take precedence over the Hunter Operator's Manual. If information in the Hunter Operator's Manual differs from that in the OEM manuals, follow the information in the OEM manuals.

1.6 Warranties

Nearly all OEM equipment has its own limited warranties. Warranty registration cards are in your Operator's packet.

Locate and read the individual warranties; put them together for easy, future reference.

For international owner's; your warranty can be found in your CE compliant Owner's Manual.

For U.S. and non-EU compliant countries, your warranty

info can be found in the Warranty section, chapter 3 of the Operator's Manual.

1.7 Hull Identification Number (HIN)

The "Hull Identification Number" located on the starboard aft side, is the most important identifying factor, and must be included in all correspondence and orders. Failure to include it creates delays. Also of vital importance are the engine serial numbers and part numbers when writing about or ordering parts for your engine. Refer to the engine manufacturers manuals for locations of engine serial numbers, and record them for future reference.

US-HUNCXXXDXXX Hull Number format:

"US" - country origin, "LHR" - Manufacturer, "C" - length code, "XXX" - hull number, "D" - month code, "X" - year code, "XX" - model year

1.8 Manufacturers Certifications

As a boat manufacturer Hunter builds their products to guidelines established under the Federal Boat Safety Act of 1971. The act is promulgated by the U.S. Coast Guard who has authority to enforce these laws on boat manufacturers that sell products in the United States. Hunter ensures that all of its products comply with these laws.

The NMMA, National Marine Manufacturers Association, provides Hunter with a third party certification. The NMMA is an organization that represents the marine industry and assists manufacturers, boat dealers, marinas, repair yards and component suppliers in areas of legislation, environmental concerns, marine business growth, and state and federal government agency interaction. The third party certification that Hunter participates in, uses well known Standards and Recommended Practices of the ABYC, American Boat and Safety Council.

We at Hunter participate extensively in the ABYC, which is all non-profit, and develops and publishes voluntary standards and recommended practices for boat and equipment design, construction, service and repair. We utilize all applicable ABYC standards in the construction of Hunter boats.

Finally Hunter sells their products worldwide, and as such must conform to the various rules and regulations required by other countries. Most notably are the ISO

standards in Europe which require the application of the CE (Common European) mark. This mark, much like the NMMA certification here in the U.S., gives you the boat owner specific information concerning your boat.

1.9 Service, Parts, and Repair for your Boat

When your boat needs serviced, parts, or repair, take it to an authorized Hunter dealer. To find a dealer in your area call 800-771-5556, or internationally you can call 01-305-824600. To find repair and parts facilities for the equipment installed on your boat, refer to the manual for that component.

If a problem is not handled to your satisfaction:

Discuss any warranty related problems directly with the service manager of the dealership or your sales person. Give the dealer an opportunity to help the service department resolve the matter for you.

If a problem arises that has not been resolved to your satisfaction by your dealer, contact Hunter at 800-771-5556, and the appropriate customer service department information will be provided to you.



H U N T E R[®]

MARINE CORPORATION

AN EMPLOYEE OWNERSHIP COMPANY

We Go The Distance

Chapter 2

***Documents
& Forms***

Hunter 50cc



Hunter 50cc • Documents and Forms

Your Hunter dealer completes the Pre-Delivery Inspection Report (Fig. 2.1) before you take delivery of your boat. It is the dealer's responsibility to both you and to Hunter to give your boat a final inspection. The purpose of this inspection is to assure proper adjustment and operation of the entire vessel. Your dealer should provide you with the Pre-Delivery Inspection Report at the time of delivery.

Hunter will not pay warranty costs for items that should have been covered in the pre-delivery service inspection and recorded on the Pre-Delivery Inspection Report.

Owners must coordinate with the dealer to insure Hunter warranty registration is completed and returned to Hunter.

Inserted at the end of this section are several records you will find helpful.

Use the BOAT RECORD (Fig. 2.2) to record all important information about your boat and its equipment. After your dealer has recorded all the information, remove the record from your Owner's Manual and store in a safe place. Do not keep this form aboard your boat.

The FLOAT PLAN (Fig 2.4) provides a record of your destination, departure and return times, boat description, passenger list, and other information about the trip you have planned. At the bottom of the form is space for listing emergency phone numbers in case your return is delayed past the expected time. It also has space for indicating information about the person filling the report. Leave the completed form ashore with a responsible person. We recommend you make several copies of this form each boating season to make sure you have a good supply.

The MAINTENANCE LOG (Fig 2.5) helps to keep maintenance records in one place. Using this log will allow you to track maintenance work that has been completed and to determine when maintenance is required. Your dealer will also find this information helpful. If you decide to sell your boat, the maintenance record will make your boat seeable because it tells prospective buyers that you have taken good care of your boat.

The ACCIDENT REPORT. No one likes to think about having a boating accident, but boating accidents do happen. You must file an accident report after a boating accident just as you must file an accident report after an automobile accident. A copy of the U.S. Coast Guard Accident Report is included at the end of this section.

You can get more copies of the report by calling the U.S. Coast Guard Boating Safety Hotline at 1-800-368-5674.

You must file this report with the U.S. Coast Guard within 48 hours after an accident resulting in one of the following:

A person disappears from a vessel under circumstances that indicate death or injury

Personal injury requiring medical treatment beyond first aid

Damage to the vessel or property damage

Complete loss of the vessel

State statutes determine whether you must file an accident report in this case. An accident report must be filed if the damage exceeds a threshold dollar value as established by the states, the threshold is \$100-\$200. Call the Boating Safety Hotline (800-368-5647) to verify the threshold for a particular state.

Note: State and local agencies may also have accident reporting requirements. Check with local enforcement agencies or with your local Hunter dealer regarding local requirements.

All Hunter boats are built in compliance with applicable United States Coast Guard regulations and recommendations at the time of construction.

Hunter boats comply with the standards developed by the National Marine Manufacturers Association (NMMA) for its Boat Certification Program.

The locator drawings will help you find the location of devices and equipment.

NOTE: Efforts have been made to make the drawings in this manual consistent with production. However, in the effort to improve this vessel, modifications have been made in the design that may date some of the drawings in this manual.

On the next few pages you will find sample forms for some of the issues dealing with your new boat. Familiarize yourself with these forms, use them, they can be very handy.

Dear Hunter Owner,

Attached you will find a list of items and recommendations that we believe should be incorporated into your own ongoing list of preventative maintenance items and safety check points. THIS LIST SHOULD NOT BE CONSIDERED A COMPLETE SERVICE MANUAL OR THE ONLY ITEMS ON YOUR BOAT IN NEED OF ROUTINE MAINTENANCE, INSPECTION OR ATTENTION.

You will find that we address commonly found optional equipment items installed on Hunter boats, as well as most standard equipment from Hunter Marine. Owner's need to familiarize themselves with individual equipment manuals on all such items, especially aftermarket purchases or optional equipment installed by your dealer or Hunter Marine. This should insure that you are following the manufacturer's recommendations for proper maintenance and up-keep.

We strongly recommend that all owners complete a Power Squadron course followed with a complementary boat inspection before leaving the dock. To locate a Power Squadron in your area please visit < www.usps.org >.

Reviewing and familiarizing yourself with the Chapman's Piloting Manual is also highly recommended for every boat owner. This manual contains demonstrations for safety drills which should be practiced routinely, dealing with adverse conditions, general boat handling and recommended safety equipment. Our opinion is that no boat owner should operate a boat without first reviewing this manual and without having ready access to it while sailing.

We hope that this list will be beneficial to you in your ongoing maintenance and upkeep. Safe boating!

Thank You

Hunter Marine

Preliminary care and maintenance checklist

A qualified Technician should be used if you are not completely confident in your ability to make repairs or inspections.

Out of Water Inspection

Pre-launch inspection

- Sacrificial zinc anodes installed
- Propeller installed with keyway, nuts and cotter pin
- Propeller shaft turns freely and without excess wobble
- Struts and shaft log free of corrosion
- Rudder swings easily & correct with wheel direction
- Rudder and post inspected for cracks and/or concealed damage (may require removing rudder)
- Auxiliary tiller handle properly aligned, fits securely and operational
- All thru-hulls and valves below water line inspected for corrosion, labeled and closed until after launch
- Bottom paint in satisfactory condition
- Hull freshly cleaned and waxed (free of gelcoat damage)
- Mooring, safety lines and fenders onboard and in good condition
- House & engine start batteries installed and filled with correct electrolyte levels
- House & engine start battery boxes secured
- All battery terminals clean and wires secured
- Engine block & transmission drains closed
- Speed / Depth transducers in place. Speed paddle wheel rotates smoothly
- Hose clamps on all systems below water line tight
- Keel bolts tight and clean
- Exhaust hose attached and secured
- Boat is free of internal and external water leaks above water line

(Failure to stop water intrusion could result in permanent damage or deterioration of structural coring materials, internal wiring and cause mildew and molding)

Mast Assembly

- Review manufacturers manual for maintenance and up-keep
- Spreaders securely fastened
- Mast and spreaders free of corrosion and stress cracks
- Standing rigging and pins inspected for wear, tear, corrosion and cracking
- External wiring secured for anchor, steaming and deck lights
- Electronic wind indicator installed per manufacturers recommendation
- Manual wind indicator installed on masthead
- VHF antenna installed and connected
- Headsail furling system installed inspected per manufacturers recommendation
- Running rigging inspected for wear and tear
- Mast step stand-up blocks secured and operational
- Main Sail, jib sail and flaking system inspected for wear and tear (non-furling mast).
- In- mast system checked for smooth operation and overall condition of sails
- Specified pre-bend and diagonal tensions attained in mast. See owners manual
- Mast to deck wiring properly sealed with drip loop

Anchor System and Ground Tackle

- ___ Anchor windlass inspected per manufacturers recommendation
- ___ Anchor secured in bow roller assembly
- ___ Spare anchor onboard and accessible.
- ___ See Chapman's Manual for recommendations on anchors, anchor lines and drogues
- ___ Anchor line pays out and retrieves into anchor locker without difficulty
- ___ Bitter end of anchor line secured
- ___ Anchor rode inspected and free of abrasions
- ___ Anchor chain shackle lock-wired at pin after secured to anchor and corrosion free
- ___ Anchor locker hatch secures properly with anchor and line in place
- ___ Anchor locker free of debris inside
- ___ Anchor locker drains open

Fuel System

- ___ Tank fuel level indicator functioning properly
- ___ Fuel clean and treated with engine manufacturers recommended additives
- ___ Primary and secondary filters cleaned or replaced
- ___ Fuel tank supply valves open
- ___ Fuel tank vent clear from tank to atmosphere (hose has anti-siphoned loop in place at hull or deck side)

Steering System

- ___ Inspect and service steering system according to manufacturer's recommendation
- ___ Clean and grease autopilot drive chains
- ___ Ensure compass light is operational

Primary Pumps Functional

- ___ Manual bilge pumps
- ___ Electric bilge pumps and float switches (discharge hose has anti-siphon loop in place to prevent back flow under sail)
- ___ Macerator pumps
- ___ Fresh water pumps
- ___ Toilet flush pumps
- ___ Shower sump pumps
- ___ High water bilge alarm pump

Illumination and small electrical components check

- ___ Bow light
- ___ Cabin lights
- ___ Stern light
- ___ Deck light
- ___ Instrument lamps
- ___ Masthead light
- ___ Chart light
- ___ Anchor light
- ___ Courtesy lights
- ___ Reading lights
- ___ Distribution panel lights

- ___ Smoke detectors operational
- ___ CO detectors operational (one per cabin recommended)
- ___ Engine & generator room blower operational
- ___ Auto fire suppression system operational (engine compartment)
- ___ Shore power cord and adapter plug operational. See manufacturer's manual for complete details
- ___ 110 or 220 VAC outlets operational - Ground fault circuits functioning
- ___ 110 or 220 VAC inverter/battery charging systems functioning properly
- ___ Cockpit control systems operational

Fresh Water Systems

- ___ Hot water heater drains shut
- ___ All spigots and hose bibs shut
- ___ All tanks flushed clean and free of debris and antifreeze
- ___ Water heater tank and lines flushed of antifreeze
- ___ All water lines and components purged of air and checked for leaks
- ___ Sinks and drains checked for leaks and adequate flow
- ___ Cockpit shower operational
- ___ Fresh water filters clean
- ___ Tank water level indicator systems operating- labeling and tank valve selection correspond

Head and Holding Tank Systems

- ___ Vent clear from tank to atmosphere
- ___ Filled with fresh water and test pumped with macerator
- ___ Toilets flush to holding tanks properly
- ___ Waste level indicating system properly functioning
- ___ No leaks at any hose fitting within the system

Galley Systems

- ___ Gas bottle filled installed and connected to regulator. Inspect Gas system for leaks after 3 minutes.
Should a leak be detected immediately close the main valve exit boat and seek professional assistance for a thorough inspection.
- ___ Stove and oven operational. Refer to manufacturer's manual for proper operation and trouble shooting.
- ___ Gimbal latch secure and operational
- ___ LPG stowage locker drain open and tank storage area free of derbies.
- ___ Microwave operational
- ___ Refrigerator operational and proper temperature attained
- ___ Freezer operational and proper temperature attained
- ___ USCG waste disposal-warning poster onboard or in owner's package
- ___ Icebox drains to sump or bilge properly
- ___ Icebox drain plugs installed

Topside Inspection

- ___ Swim seats / ladders / gates operational
- ___ Swim seat latch operating correctly
- ___ Cockpit hatches operate properly (adjustments should be made with boat in water)
- ___ Canvas properly cleaned and installed
- ___ Cockpit cushions cleaned and installed
- ___ Lifeline fittings tight and secure

Hunter 50cc • Documents and Forms

- ___ Rubrail sealed secured to hull
- ___ Sliding hatches drains free of debris
- ___ Companionway drop-ins fit properly in companionway and stowage rack
- ___ Load bearing hardware securely fastened. This includes but is not limited to chainplates, winches and handrails
- ___ Traveler arch securely fastened. Stainless Steel models should be properly grounded
- ___ **See owners manual for details**
- ___ Plexiglas hatches, ports, windscreens and windows adjusted and cleaned.
- ___ **Cleaners and polishers specifically for Plexiglas can be purchased from most marine supply stores**
- ___ External teak cleaned and oiled (Teak decking cleaned with mild soap and water)
- ___ External railings cleaned with soap and water then hand polished using automotive wax
- ___ All deck fill caps seal properly and have retainer chains intact (except Waste Pump-out)
- ___ Dorade vents or sealing caps installed
- ___ Topside surface clean and free of gelcoat damage

Interior Inspection

- ___ Drop-in hatches for bunks and floors in place and fit securely
- ___ Interior steps and grab rails secured
- ___ Bilges clean and free of debris
- ___ Opening port and hatch screens in place
- ___ Blinds / privacy curtains, shades and interior cushions cleaned, installed and secured
- ___ All doors open / shut / latch properly
- ___ Insure all wires and connection on distribution panels are tight (should be professionally inspected)
- ___ Television / VCR operational
- ___ Stereo / Tape / CD operational
- ___ Chapman's Manual onboard and readily available
- ___ Safety gear onboard readily available and up to date.
- ___ **See Chapman's Manual and US Coast Guard website at < www.uscg.mil >for details.**
- ___ Boat owner's manual onboard

In Water Inspection

Dockside inspection of Engine, Pre-start sequence and operating system

- ___ Review engine manual for maintenance requirements and proper starting procedure
- ___ Propeller shaft properly aligned (per engine manual)
- ___ Shaft to engine coupling bolted and properly torque (per engine manual)
- ___ All engine mounting bolts in place and properly torque (per engine manual)
- ___ Crankcase oil at full mark (per engine manual)
- ___ Transmission fluid / oil at full mark (per engine manual)
- ___ Coolant mix ratio proper - heat exchanger and expansion tanks full (per engine manual)
- ___ Seawater intake valve open and no leaks
- ___ Air bled from fuel lines and system
- ___ No fuel leaks at any fittings
- ___ Throttle linkages smooth and operational
- ___ Shutdown system operational
- ___ USCG Oil Discharge warning poster in place
- ___ Exhaust elbows and hoses tight
- ___ Starting sequence and alarms correct
- ___ Oil pressure acceptable (per engine manual)
- ___ Coolant temperature acceptable (per engine manual)

- ___ Alternator DC output at rated rpm (per engine manual)
- ___ Correct Idle rpm (per engine manual)
- ___ Water discharged with exhaust
- ___ Hour meter operational
- ___ Fuel level indicators operational
- ___ Throttle cable tension set properly
- ___ Shifter operation correct
- ___ Neutral safety start switch operational
- ___ No inboard exhaust gas leaks
- ___ No fuel / oil / water leaks on engine
- ___ Shaft packing / Drip free Seal adjusted and locknuts tight.
One to three drips per minute with shaft turning on traditional packing assembly
- ___ Engine box installed and secured

Dockside inspection of Generator, Pre-start sequence and operating system

- ___ Review and follow manufacturer's manual for maintenance and up-keep
- ___ Seawater strainer water-tight and clean
- ___ No leaks in fuel system - Fuel filters clean
- ___ Lube oil at full mark
- ___ Coolant level full - proper mix ratio with water (per generator manual)
- ___ Seawater discharge overboard with exhaust gas
- ___ No inboard water or exhaust gas leaks
- ___ Proper voltage output to distribution panel (per generator manual)
- ___ Ship / Shore power transfer panel function properly
- ___ Starter battery box secured
- ___ Starter battery cable connections clean and tight
- ___ Starting battery electrolyte level proper

Climate Control System

- ___ Review and follow manufacturers manual for maintenance and up-keep
- ___ Seawater strainer water tight and clean
- ___ Seawater pump air purged and operational
- ___ Seawater flow adequate fwd and aft
- ___ Fwd system functions properly in all modes of operation
- ___ Aft system functions properly in all modes of operation
- ___ No seawater leaks in system components and lines
- ___ No condensation leaks to deck or liner
- ___ Air return/intake filters clean and clear
- ___ 110 or 220 VAC shore power wired correctly at dock
- ___ Remote control units and display features operate correctly
- ___ Condensation drains open

Pre-departure Checklist

- ___ Check bilge for extra water
- ___ Check weather conditions and tides
- ___ Check food Supply
- ___ Foul weather gear
- ___ Linen, sleeping bags
- ___ Fuel

- ___ Water
- ___ Sunscreen and sunglasses
- ___ Tools
- ___ Docking and anchoring gear
- ___ Check radio operation
- ___ Navigation charts and instruments
- ___ Float plan to a friend or Coast Guard
- ___ Fuel for Stove
- ___ Cooking and eating utensils
- ___ check battery water level
- ___ oil level, tight V-belts
- ___ Check for loose electrical connections in the engine compartment
- ___ Secure loose tools or equipment in the engine compartment so as to not get fouled in the engine.
- ___ AC systems off, electrical cord stowed
- ___ Doors and drawers secure
- ___ Check steering lock to lock
- ___ Check mast for rigging irregularities and tightness
- ___ Halyards and sheets are ready to run
- ___ no lines or obstructions near propeller or bow
- ___ Anchor ready to run
- ___ Check lifelines for tightness
- ___ Turn on waterlines
- ___ Stow all loose gear
- ___ Open engine cooling water thru intake valve

After Sailing Checklist

When leaving your Hunter at the dock for more than a short time, it is a good idea to review the following checklist to make sure everything is in order. This will help protect the various parts of your boat and add considerably to their attractiveness and usable life.

- ___ Flake or furl mainsail and cover, or remove and bag.
- ___ Remove and stow all portable deck hardware such as snatch blocks, winch handles, etc.
- ___ Secure the boom to the topping lifts and set it firmly amidships with the main sheet purchase.
(It is also a good idea to rig a line from the steering wheel or tiller to a convenience cleat to keep the rudder from swinging back and forth with the motion of the water or employ the wheel brake if so equipped.)
- ___ Attach the shackle ends of all halyards to convenient fittings and take up slack. Find a location leading away from the mast to keep the halyard from slapping the mast.
- ___ Coil and stow all lines in line lockers
- ___ Cover the winches and steering pedestal when leaving the boat for several days or more
- ___ Close all fuel lines and seacocks
- ___ Switch off the electrical system
- ___ Pump out the bilge
- ___ Check air vents, secure ports and hatches, swab the deck, and clean deck stainless, particularly if you have operated in salt water.

Pre-delivery Service Record

Fig. 2.1

DEALER: _____ ENGINE: _____
MAKE: _____ OWNER: _____
PORT ENGINE NO: _____ STBD. ENGINE NO: _____
BOAT NAME: _____ REGISTRY NO: _____
OPERATION _____ INITIALS _____ OPERATION _____ INITIALS _____

BEFORE LAUNCHING

- 1. Hull Side Clean and Gelcoat
- 2. Bright work clean and finish
- 3. Decks cleaned and gelcoat
- 4. Interior Finish
- 5. Upholstery clean and carpet in place
- 6. Bilge cleaned.
- 7. Bottom clean and paint
- 8. Both shafts turn freely
- 9. Engines and Generator intakes installed
- 10. All hull fittings sealed
- 11. All drain plugs tight, (hull, engines, generator, muffler)
- 12. Sacrificial Anodes installed

WITH BOAT IN WATER

- 13. Hose test for cabin and window leaks
- 14. No water leaks at thru hull fitting with seacocks
- 15. No water leaks at shaft or rudder
- 16. With all switches off - no spark when battery cable touched to post
- 17. All electrical equipment operating including: horn(); running light(); bilge pump()
- 18. Toilet operates
- 19. Water (pressure) system operates
- 20. Galley stove operates
- 21. With fuel tanks full, no fuel leaks at fill pipes, overflow vent, or at any fuel line connections
- 22. With coupling disconnected, engine and shaft alignment

INSPECTION DATE: _____

DEALERS SIGNATURE: _____

OWNERS SIGNATURE: _____

COMMENTS: _____

BEFORE STARTING ENGINES

- 23. All engine wiring in good order & tight
- 24. Throttle control and cable travel
- 25. Clutch control and cable travel
- 26. Crankcase oil level at FULL mark
- 27. Reverse gear oil level at FULL mark
- 28. No fuel leaks in fuel lines, at fittings, at fuel filter, fuel pump
- 29. No engine water or oil leaks
- 30. Oil pressure and exhaust water flow
- 31. Idling speed set at 700-800 RPM and is in proper adjustment

WATER TEST BOAT

- 33. Engine performance
- 34. Instruments are registering properly
- 35. Top RPM wide open throttle for one minute after warm-up
- 36. Boat performance

FINAL CHECK:

- 37. All accessory equipment operating
- 38. Carpets and drapes installed and clean
- 39. All loose equipment on boat ready for new owner.

Float Plan

Name of Operator _____ Age _____

Address _____

Phone _____

Boat Make _____ Model _____

Length _____ Hull Color _____ Deck Color _____

Registration No. _____ Home Port _____

Radio frequencies _____

Equipment on Board, PFDs, Flares, Anchor _____

Fuel Capacity _____ Water Capacity _____

Distinguishing Features _____

Departed from _____

Date _____ Time _____

Destination _____

Stops _____

Estimated time of Arrival: Date _____ Time _____

Name, age, address and phone number of other persons on board:



HUNTER®

MARINE CORPORATION

AN EMPLOYEE OWNERSHIP COMPANY

We Go The Distance

Chapter 3

Warranty

Hunter 50cc



This Page Intentionally Left Blank



HUNTER®
MARINE CORPORATION
AN EMPLOYEE OWNERSHIP COMPANY
DISCOVER THE DIFFERENCE

Your Hunter Warranty

Hunter offers a limited warranty on every Hunter boat sold through an authorized Hunter dealer. A copy of this warranty is included here, and in your Operator's Manual. If for some reason you are not able to understand, read, or view this manual, please contact your local dealer for a replacement copy.

We stand behind the quality of your boat with our limited warranty, which you should review. To insure the operation and validity of your limited warranty, please complete the attached card and send it to us within ten (10) days of the purchase date. Section 15 of the U.S. Federal Boat Safety Act requires registration of a boat's first owner. The warranty data should also be recorded in the space below for your own reference.

The following warranties apply to all 2009 Model Year boats produced by
HUNTER MARINE CORPORATION:

LIMITED ONE-YEAR WARRANTY

Hunter Marine warrants to the first-use purchaser and any subsequent owner during the limited warranty period that any part manufactured by Hunter will be free of defects caused by faulty workmanship or materials for a period of twelve (12) months from the date of delivery to the first-use purchaser under normal use and service. During this period, as the sole and exclusive remedy, Hunter's obligation under the warranty is limited to the repair or replacement of any such defective part.

LIMITED FIVE-YEAR HULL STRUCTURE AND BOTTOM BLISTER WARRANTY

Hunter warrants to the first-use purchaser and any subsequent owner during the limited warranty period that the hull of each boat will be free from structural defects in materials and workmanship for a period of five (5) years from the date of delivery to the first-use purchaser under normal use and service.

This limited warranty applies only to the structural integrity of the hull and the supporting pan/grid or stringer system. Hulls, pan/grid or stringers modified in any way or powered with engines other than the type and size installed or specified by Hunter are not covered by this limited warranty. As the sole and exclusive remedy, Hunter's obligation under the warranty is limited to repair or replacement of any such defective part.

Hunter • Warranty

Hunter also warrants to the first-use purchaser and any subsequent owner during the warranty period that the boat will be free from gelcoat blistering on underwater surfaces of the hull, excluding the keel and rudder, for a period of five (5) years from the date of delivery to the first-use purchaser under normal use and service. During this period, Hunter will supply or reimburse an authorized Hunter dealer for all of the parts and labor required to repair a blistered underwater surface of the hull. The labor cost reimbursement will be based on the Labor Allowance Schedule established by Hunter from time to time, however if the repair is performed by a non-Hunter dealer, the repair cost must be authorized by Hunter in advance and be based on a reasonable number of hours as determined by Hunter. Hunter will not pay transportation, hauling, launching, bottom paint, storage, dockage, cradling rental, rigging and derigging, or other similar costs. It is recommended that the repair be done during a seasonal haul out for service or storage.

PLEASE KEEP THIS MANUAL IN A SAFE PLACE AND HAND IT OVER TO THE
NEW OWNER IF YOU SELL THE CRAFT.

You should also complete the warranty cards for your engine, stove, head, electric water pump and other accessories. These are enclosed in the manufacturers' manuals that are packaged with your owner's manual.

HUNTER EXPRESSLY DISCLAIMS THE IMPLIED WARRANTIES OF
MERCHANTABILITY AND FITNESS. NEITHER HUNTER OR THE SELLING DEALER SHALL
HAVE ANY RESPONSIBILITY FOR LOSS OF USE OF A BOAT, LOSS OF TIME,
INCONVENIENCE, COMMERCIAL LOSS, OR CONSEQUENTIAL DAMAGES.

The following circumstances will void the bottom blister limited warranty:

- (1) If the gel-coat has been sanded, sandblasted, or subjected to abrasion or impact.
- (2) If the instructions provided in the Hunter Owner's Manual are not followed according to Hunter's required bottom preparation procedures.

RESTRICTIONS APPLICABLE TO WARRANTIES

These limited warranties do not cover:

- (1.) Paint, window glass, Gelcoat, upholstery damage, plastic finishes, engines, engine parts, bilge pumps, stoves, blowers, pressure water pumps, propellers, shafts, rudders, controls, instruments, keels and equipment not manufactured by HUNTER. Any warranty made and issued by the manufacturer of such items will be, if and where available, provided to the first use purchaser.
- (2.) Problems caused by improper maintenance, storage, cradling, blocking, normal wear and tear, misuse, neglect, accident, corrosion, electrolysis or improper operation.
- (3) Boats used for commercial activities including charter.

THESE LIMITED WARRANTIES ARE YOUR SOLE AND EXCLUSIVE REMEDIES AND ARE EXPRESSLY IN LIEU OF ANY AND ALL OTHER REMEDIES AND WARRANTIES EXPRESSED AND IMPLIED, INCLUDING THE WARRANTIES OF MERCHANTABILITY AND FITNESS FOR A PARTICULAR PURPOSE, WHETHER ARISING BY LAW, CUSTOM, CONDUCT, OR USAGE OF TRADE. SOME STATES DO NOT ALLOW LIMITATIONS ON HOW LONG AN IMPLIED WARRANTY LASTS, SO THE ABOVE LIMITATION MAY NOT APPLY TO YOU. IN THE EVENT THAT IMPLIED WARRANTIES ARE FOUND TO EXIST UNDER THE LAW OF A PARTICULAR STATE, NOTWITHSTANDING THE EXCLUSION CONTAINED HEREIN, THE DURATION OF ANY SUCH IMPLIED WARRANTY SHALL BE LIMITED TO THE DURATION OF THE APPLICABLE LIMITED WARRANTY STATED HEREIN. THE PURCHASER ACKNOWLEDGES THAT NO OTHER REPRESENTATIONS WERE MADE TO HIM OR HER WITH RESPECT TO THE QUALITY OR FUNCTION OF THE BOAT. ANY ORAL STATEMENT OR PRINTED MATERIAL ADVERTISING THE BOAT WHICH SPEAKS TO ANY PERFORMANCE CHARACTERISTIC OF THE BOAT OR ANY OF ITS COMPONENTS SHALL BE CONSIDERED AND CONSTRUED AS AN ESTIMATED DESCRIPTION ONLY AND SHOULD NOT BE RELIED UPON AS AN EXPRESS WARRANTY OR AS THE BASIS OF THE BARGAIN FOR THE BOAT OR ANY OF ITS COMPONENTS.

ANY CONSEQUENTIAL, INDIRECT OR INCIDENTAL DAMAGES WHICH MAY BE INCURRED ARE EXCLUDED AND PURCHASER'S REMEDY IS LIMITED TO REPAIRS OR REPLACEMENT OF ANY SUCH PART(S). SOME STATES DO NOT ALLOW THE EXCLUSION OR LIMITATION OF INCIDENTAL OR CONSEQUENTIAL OR INDIRECT DAMAGES, SO THE ABOVE LIMITATION OR EXCLUSION MAY NOT APPLY TO YOU. THIS WARRANTY GIVES YOU SPECIFIC LEGAL RIGHTS, AND YOU MAY ALSO HAVE OTHER RIGHTS WHICH VARY FROM STATE TO STATE.

OWNER INFORMATION CARD

HULL IDENTIFICATION NUMBER IS ON THE STARBOARD AFT SIDE OF THE HULL OR TRANSOM. THIS NUMBER MUST BE GIVEN IN ALL NECESSARY CORRESPONDENCE.

HULL NO. _____

DATE DELIVERED TO OWNER _____

YACHT NAME _____

OWNER NAME _____

STREET ADDRESS _____

CITY _____

STATE/COUNTRY _____

ZIP CODE _____

HOME PORT _____

ENGINE MODEL _____

SERIAL NO. _____

PROPELLER SIZE _____

DEALER _____

PHONE _____

STREET ADDRESS _____

CITY _____

STATE/COUNTRY _____

ZIP CODE _____

CUSTOMER SERVICE / WARRANTY

===== WARRANTY REGISTRATION =====

These limited warranties shall not be effective unless the HUNTER Warranty Registration Form and Pre-Delivery Service Record, which are furnished with each new boat, are filled out completely and re-turned to HUNTER within ten (10) days of delivery.

Return of the Warranty Registration Form to HUNTER, signed by both Dealer and Owner, is critical. Warranty coverage cannot be initiated until the completed form is received at HUNTER.

All repairs and/or replacements will be made by an authorized Hunter dealer, or at the option of Hunter, at the Hunter plant. If the repairs are of such a nature that the warranty work must be performed at the HUNTER plant, transportation costs to and from the HUNTER plant shall be paid by the owner. The labor cost reimbursement will be based on a Labor Allowance Schedule established by HUNTER and where not applicable, on a reasonable number of hours as determined by HUNTER. Any repairs and replacements must be approved in advance by an authorized HUNTER service representative.

===== TRANSFER OF LIMITED WARRANTIES =====

For 1995 and later hull numbers, the limited warranties will be transferred to a subsequent purchaser of the boat if:

- (1) A notice of the transfer of ownership of the boat is given by the subsequent purchaser in writing to Hunter within thirty (30) days of the transfer.
- (2) The notice shall include the name, address and telephone number of the subsequent purchaser, the date of purchase, the hull number and the name of the seller of the boat.

Hunter will mail to the subsequent purchaser notice of the expiration dates of the limited warranties (see form letter, attached). The transfer of the ownership of the boat will not extend the expiration dates of the limited warranties.

===== CUSTOMER SATISFACTION SURVEYS =====

During the first year of ownership, the first purchaser will receive two Customer Satisfaction Surveys - the first (CSS#1) will be received shortly after taking delivery and focuses on the dealer's ability to sell and commission the boat, and the Owner's initial satisfaction. The second survey (CSS#2), nine to ten months into ownership, "measures" dealer service capability and allows the owner to evaluate most of the boat's functional systems and characteristics. Both surveys are dependent upon receipt of the first purchaser's Warranty Registration Form.

SAMPLE FORM LETTER

March 12, 1997

Mr. John Smith
1456 Joy Street
Sarasota, FL 34266

Dear Mr. Smith,

Thank you for providing written notice of transfer of ownership. We are pleased you have selected a Hunter sailboat and we will make every effort to assure Hunter ownership will be a satisfying experience for you.

Based on the information you have provided, we are pleased to notify you of the expiration dates of the limited warranties.

- The limited one-year New Boat warranty expires (d)_____.
- The limited five-year Hull Structure and Bottom Blister warranty expires (d)_____.

Should you require assistance at any time during ownership, we encourage you to contact your Hunter dealer or to call us directly at 386-462-3077.

Please confirm the information at the bottom of the page and advise us if any corrections are required.

Customer Service Manager

Hull No: HUN_____ Model:_____

Telephone: (H)_____ (B)_____

Date of Purchase:_____

Purchased From: Name:_____

Address:_____

City/State_____ Zip_____

() Private Owner () Dealer



HUNTER®

MARINE CORPORATION

AN EMPLOYEE OWNERSHIP COMPANY

We Go The Distance

Chapter 4

Boating Safety

Hunter 50cc



As you read your owner's manual, please note hazard warnings which alert you to safety and precautions and unsafe conditions or operating procedures. We have included these warnings because we are concerned about your safety and the safety of your passengers. Hazard statements generally have five parts:

1. The hazard symbol.
2. A signal word which indicates the severity of the hazard.
3. A concise description of the hazard.
4. The results of ignoring the hazard.
5. Steps for avoiding the hazard:

The three signal words which indicate the severity of a hazard are danger, warning, and caution. The meanings they convey are as follows:



Calls attention to immediate hazards that will result in severe injury or death.



Identifies hazards or unsafe practices that could result in personal injury or death.



Indicates hazards or unsafe practices that could result in minor personal injuries, property damage, or component damage.

Also included in this manual are owner advisory statements identified as "Important" or "Note". Unlike the hazard communication statements, they alert you to conditions affecting equipment operation, maintenance, and servicing practices.

Important: This is a general advisory statement or procedure intended to prevent damage to the equipment or associated component.

Note: This is a general advisory statement relating to equipment operating and maintenance procedures. Its intent is to call attention to information more important than normal text.

4.1 Safety

Boating safety and the safety of your passengers are your responsibility. You should fully understand and become familiar with the operating and safety procedures and precautions in this manual and the other manuals in the owner's packet before you launch your new boat.

4.1.1 Safe Operation

Following is general information about safe operation.

Keep your boat and equipment in safe operating condition. Inspect the hull, engines, safety equipment, and all boating gear regularly.

Important: Federal law requires you, the owner, or operator to provide and maintain safety equipment on your new boat. Consult your Coast Guard, state, and local regulations to ensure your boat has all required safety equipment on board. Additional equipment may be recommended for your safety and that of your passengers. Make yourself aware of its availability and use.

BE VERY CAREFUL when fueling your boat. Be sure you know the capacity of your boat's fuel tank and the amount of fuel you use when operating at frequently used engine speeds (RPMs).

Always know all the area's on the boat, know the nautical terms for the different areas of your boat. On the following page, at the end of this chapter we show you a general layout of these terms and illustrate the areas that may be of importance to you.

Make sure you have enough fuel on board for anticipated cruising requirements. In general, use 1/3 of your supply to reach your destination and 1/3 to return. Keep 1/3 in reserve for changes in your plans due to weather or other circumstances.

Note: Your generator supply line is located higher on the auxiliary fuel tank than the engine's supply lines. This is for your safety in that your generator cannot deplete your fuel supply should it ever be left running.

Be sure lifesaving and fire extinguishing equipment is on board. This equipment must meet regulatory agency standards, and it should be noticeable, accessible, and in a safe operating condition. Your passengers should know where this equipment is and how to use it.

- Keep an eye on the weather. Be aware of possible changing conditions by checking a local weather report before your departure. Monitor strong winds and electrical storms closely.
- Always keep accurate, updated charts of the area on board your boat.
- Before you leave the port or harbor, file a float plan with a family member, relative, friend, or other responsible person ashore.
- Always operate your boat with care, courtesy, and common sense.
- Instruct at least one other passenger aboard in the operating procedures in handling your boat. This person can take over if you unexpectedly become unable to do so.
- Do not allow passengers to ride on parts of your boat other than designated seating areas.
- Ask all passengers to remain seated while the boat is in motion.
- Do not use the swim platform or boarding ladder while engines are running.
- Understand and obey the “Rules of the Road.” Always maintain complete control of your boat.
- Do not overload or improperly load your boat.

4.1.2 Safe Boating Courses

Your local U.S. Coast Guard Auxiliary and the U.S. Power Squadrons offer comprehensive safe boating classes several times a year. You may contact the Boat/U.S. Foundation at 1-800-335-BOAT (2628), or in Virginia 1-800-245-BOAT (2628). For a course schedule in your area, you may also contact your local U.S. Coast Guard Auxiliary or Power Squadron Flotilla for the time and place of their next scheduled classes.

4.1.3 Voluntary Inspections

State boating officials in many states or the U.S. Coast Guard Auxiliary offer courtesy inspections to check out your craft. They check your boat for compliance with safety standards and required safety equipment. You may voluntarily consent to one of these inspections and

are allowed time to make correction without prosecution. Check with the appropriate state agency or the Coast Guard Auxiliary for details.

4.1.4 Rules of the Road

Navigating a boat is much the same as driving an automobile. Operating either one responsibly means complying with a set of rules intended to prevent accidents. Just as you assume other car drivers know what they are doing, other boaters assume you know what you are doing.

As a responsible yachtsman, you will comply with the “Rules of the Road”, the marine traffic laws enforced by the U.S. Coast Guard. There are two sets of rules: The United States Inland Navigational Rules and the International Rules. The United States Inland Rules apply to all vessels inside the demarcation line separating inland and international waters. The Coast Guard publishes the “Rules of the Road” in its publication “Navigational Rules, International-Inland.” You can get a copy from your local U.S. Coast Guard Unit or the United States Coast Guard Headquarters, 1300 E Street NW, Washington, D.C. 20226.

4.1.5 Safety Equipment

Important: Federal law requires you, the owner, to provide and maintain safety equipment on your boat. Consult your Coast Guard, state, and local regulations, to ensure your boat has all required safety equipment on board. Additional equipment may be recommended for your safety and that of your passengers. Make yourself aware of its availability and use.

We have provided the following safety equipment in your Loose Gear Kit (Does not apply to UK boats):

- (3) Fire Extinguishers
- (2) Stainless Anchor Shackles
- (1) 250’ Nylon Anchor Line
- (1) 20’ Galvanized Chain
- (6) Adult Form Life Vests (PID)
- (1) White Form Cushion
- (1) United States Coast Guard Pamphlet
- (1) Anchor
- (1) Air Horn

4.1.6. Additional Equipment

You should consider having additional equipment on board to help make your boating experience safer and more enjoyable. Some examples include the following:

- Anchor and line *
- Boat hook*
- Bucket & Sponge
- Commonly used spare parts
- Distress signal kit*
- Docking lines*
- Engine and accessory manuals*
- Extra keys
- Extra V-belts
- Fenders*
- First aid kit
- Flashlight & extra batteries
- Manually operated bilge pump
- Navigational charts
- Owner's Manual
- Replacement bulbs
- VHF radio
- Spare fuel and oil filters
- Tool kit

*Provided in Loose Gear Kit (US Boats only)

4.1.7 Personal Flotation Devices (PFDs)

There must be one United States Coast Guard approved wearable personal flotation device of Type I, II, or III for each person on board your boat. The PFDs must be in serviceable condition and readily accessible. A minimum of three PFDs (two wearable and one throwable) is required regardless of the number of persons on board.

(A) PFD Type I, Wearable:

This offshore life jacket has the greatest buoyancy. It is effective for all waters where rescue may be delayed. Its design allows for turning most unconscious persons in the water from face down position to a vertical or face-up position.

(B) PFD Type II, Wearable:

This near-shore buoyant vest provides less buoyancy than a Type I PFD. It is intended for calm inland waters or waters where there is a chance of quick rescue. It turns its wearer to a face-up position as does the Type I PFD, but the turning action is not as pronounced as the Type I, and it will not turn as many persons under the same conditions as a Type I.

(C) PFD Type III, Wearable:

Classified as a flotation aid, this PFD allows wearers

to place themselves in a vertical or face-up position in the water. Type III PFD has the same minimum buoyancy as a Type II PFD. It has little or no turning ability. People participating in water sports often prefer this PFD because it is intended for use in waters where quick rescue is possible and it is generally the most comfortable for continuous wear.

(D) PFD Type IV, Throwable:

You must also have aboard at least one throwable PFD Type IV device. The Type IV device can be thrown to a person in the water and held by the user until rescued. The design does not allow it to be worn. The most common Type IV PFD are buoyant cushions or ring buoys. This PFD must be immediately available for use and in serviceable condition.

4.2 Carbon Monoxide Hazard

(See enclosed brochure concerning Carbon Monoxide poisoning and preventing)

As all responsible yachtsmen know, there are unseen dangers when boating. One danger is serious enough that we feel the need to specifically bring it to your attention. It is odorless, colorless, and tasteless, but can be harmful or fatal if inhaled. Its name is CARBON MONOXIDE (CO)

4.2.1 Carbon Monoxide Safety

This section is intended to provide educational information about carbon monoxide relative to boats and boating. Carbon Monoxide accumulation is affected by boat geometry, hatch, window, and door openings, ventilation openings, proximity to other structures and boats, wind direction, boat speed, boat maintenance, and a multitude of other variables. This section discusses many of these and enables the boat owner to better understand all conceivable variables. Therefore, the boat owner is cautioned not to exclusively rely on it to prevent the accumulation of Carbon Monoxide.

4.2.2 What is Carbon Monoxide?

Carbon Monoxide is a highly poisonous gas formed by the combination of carbon and oxygen. Commonly referred to as CO, its chemical formula is C for carbon and O for oxygen. CO is a colorless, odorless, and tasteless gas that, by itself, cannot be detected by human senses. CO

diffuses in the air much more rapidly than other gasses that are detectable by the human senses. The weight of CO is about the same as air so it does not rise or fall like other gasses but will distribute itself throughout the boat. CO is produced any time a material containing carbon is burned. In boating, these materials include, but are not limited to, gasoline, diesel fuel, or propane. All carbon based fuels produce varying amounts of CO, depending on their carbon content. Gasoline is high in carbon and, therefore, produces lower levels of CO. However, the exhaust of all engines and generators as well as any open flame device, produce CO and the same precautions should be taken regardless of the type of fuel.

4.2.3 How Carbon Monoxide Can Enter Your Boat

Any device that burns fuel creates Carbon Monoxide. For example, a propane cook-top or a space heater are both potential sources for CO. But the most serious danger comes from the gasoline engines and generators aboard your own and neighboring boats. There are four basic ways that CO from a running engine or generator can enter your boat.

The “station wagon effect” results from the aerodynamics of deck cabins and flying bridges. With the boat underway, the air flow over the top forms a low pressure area behind the cabin or transom which can suck exhaust gasses into the cockpit and the cabin inefficient trim angles also can cause the station wagon effect.

4.2.4 Symptoms of Carbon Monoxide Poisoning

Most important is to know the causes, study the symptoms, and be trained in the emergency care. This is the best way to avoid, understand, and respond to any Carbon Monoxide emergency:

One or more of the following symptoms can signal the adverse effects of Carbon Monoxide accumulation. The order of this list is generally the sequence of symptoms. However, the number of symptoms and the order of their appearance may change for different people.

Watering and Itching eyes
Tightness in the chest
Flushed Appearance
 ringing in the ears
Throbbing Temples
Inattentiveness Convulsions
Drowsiness
Headache

Dizziness
Vomiting
Collapse
Nausea
Fatigue

4.2.5 Effects of Carbon Monoxide

When inhaled, Carbon Monoxide is absorbed by the lungs and reacts with the blood hemoglobin to form carbon hemoglobin, which reduces the oxygen carrying capacity of the blood. The result is a lack of oxygen for the tissues, causing subsequent tissue death and, if prolonged, death of the individual. Carbon Monoxide in high concentrations can be fatal in a matter of minutes. Even lower concentrations must not be ignored because the affects of exposure to CO are cumulative and can be just as lethal. Certain health related problems and age increases the effects of CO. People who smoke or are exposed to high concentrations of cigarette smoke, consume alcohol, or have lung or heart disorders are particularly susceptible to an increase in the effects from CO. However, the health of all of the boat’s occupants should be considered. Physical exertion accelerates the rate at which the blood absorbs CO. The early effects of CO poisoning are easy to overlook because they are similar to the effects of other boating related stress such as eye strain, fatigue, sun exposure, seasickness, or alcohol consumption. But, as the concentration of CO in the air increases, it has increasingly adverse effects on your health.

4.2.6 When Overcome by Carbon Monoxide

When someone falls victim to Carbon Monoxide poisoning, fast and responsive action is crucial. Know the symptoms. The earlier the effects of CO are detected, the better the chances for recovery. The following list shows the sequences of events that must be done in an effort to revive a CO victim:

- Evacuate, Ventilate, Investigate, complete the Carbon Monoxide poisoning action sequence
- Move the victim to fresh air.
- Administer oxygen if available. If the victim is not breathing, perform artificial resuscitation per approved CPR procedures until medical help arrives and takes over. Prompt action can mean the difference between life and death.
- Ventilate the area.
- Investigate the source of CO and take corrective action.

- As always, you can contact the Red Cross to obtain information for training in CPR or emergency response care.

4.2.7 How to Minimize the Accumulation of Carbon Monoxide

Practice good inspection and maintenance habits. Be certain hull exhaust outlets are not blocked or restricted in any way.

Be alert for exhaust gasses from other boats. Always provide adequate ventilation when weather enclosures are in place and engines or generator is running.

Do not run with a high bow angle. Use trim tabs or redistribute the load to maintain a low bow angle. Orient your boat to maximize the dispersion of CO.

We cannot identify or describe every possible variable or combination of variables, you must continually observe passengers for symptoms or Carbon Monoxide intoxication and be aware of the many possibilities of Carbon Monoxide accumulation. For instance, poorly maintained hoses and hose connections on the generator or engine exhaust system(s) can permit Carbon Monoxide to escape into the interior of your boat. Therefore, the exhaust system must be periodically examined and maintained in order to ensure its integrity. Moreover, all accommodation spaces constantly require proper ventilation.

4.2.8 Preventative Maintenance

Frequent inspections and proper maintenance of the engine, and exhaust system, as well as, other various areas of your boat are critical in preventing the accumulation of Carbon Monoxide. It is the owner's responsibility to make sure the entire boat is inspected and maintained against CO.

The exhaust systems of your engines and generator are under constant attack from salt water, gasses, vibration, and normal wear. Inspect every exhaust system component often. Start with a visual inspection. Check each joint for discoloration, carbon buildup, stains, water leaks, or other signs of damage. Inspect all metal parts for corrosion, discoloration, or flaking. Check that all hose clamps are in good condition and properly tightened. Carefully inspect all exhaust and cooling hoses for signs of wear, dry rot, cracking, discoloration, chafing, or swelling. If any of these conditions exist, have the entire system inspected and corrected by a qualified technician

before starting the engines or generator.

Next, start each engine and generator one at a time. Follow the full run of the exhaust system, listening and looking for leaks. While doing this, make sure there is adequate ventilation and that your CO detector is on.

Other items to inspect are as follows: If your boat has access panels, check that the access panels around the engine and exhaust are in place and fit snugly to minimize the opportunity for CO to enter the cabin. There should be no large openings where CO could enter the cabin. Ensure that all ventilation systems are in good working order and are not blocked or punctured. Check all sink drains to assure that they have a good water trap to prevent CO from coming in from the outside.

Finally, because poorly running engines produce excessive CO, make sure engines and generators are tuned up. They should run smoothly and not produce black smoke. The spark plugs (gas engines) and ignition systems should be maintained regularly, and the fuel system and air filters should be in good order.

4.2.9 Carbon Monoxide Detectors

If you carefully avoid potential CO accumulation and maintain your systems properly, you have made great strides towards protecting yourself and others from the dangers of Carbon Monoxide. We have assisted you in your endeavor by providing CO detectors in each living area aboard your boat. We use only those CO detectors that are UL approved for marine use. RV and residential models won't withstand the elements of the boating environment. Most CO detectors require specific maintenance procedures to remain accurate and functional. Follow the manufacturer's instructions for the use and maintenance of the CO detectors.

It's strong recommended that you change CO and Smoke alarm batteries when changing the clocks for Daylight-Saving Time. **Replace Smoke Alarms every 10 years and replace Carbon Monoxide (CO) alarm every 5 years** since the sensors in these devices can degrade because of environmental contamination and from age. In addition to replacing batteries in smoke alarms at least once every year. Always make sure the followings:

1. Smoke/CO alarms should be tested monthly to make sure they are working in your boat.
2. Batteries should be changed once a year, when changing the time on clocks of your boat.

Know the Dangers!



Swimming near or under the back deck or swim platform. Carbon monoxide from exhaust pipes of inboard engines, outboard engines and generators build up inside and outside the boat in areas near exhaust vents. **STAY AWAY** from these exhaust vent areas and **DO NOT** swim in these areas when the motor or generator is operating. On calm days, wait at least 15 minutes after the motor or generator has been shut off before entering these areas. **NEVER** enter an enclosed area under a swim platform where exhaust is vented, not even for a second. **It only takes one or two breaths of the air in this “death chamber” for it to be fatal.**

Blockage of exhaust outlets can cause carbon monoxide to accumulate in the cabin and cockpit area - even when hatches, windows, portholes, and doors are closed.

Exhaust from another vessel that is docked, beached, or anchored alongside your boat can emit poisonous carbon monoxide gas into the cabin and cockpit of your boat. Even with properly vented exhaust, your boat should be a minimum of 20 feet from the nearest boat that is running a generator or engine.

Slow speeds or idling in the water can cause carbon monoxide gas to accumulate in the cabin, cockpit, bridge, and aft deck, even in an open area. A tailwind (force of wind entering from aft section of the motorboat) can also increase accumulation.

The “station wagon effect,” or backdrafting can cause carbon monoxide to accumulate inside the cabin, cockpit, and bridge when operating the boat at a high bow angle, with improper or heavy loading or if there is an opening which draws in exhaust.

This effect can also cause carbon monoxide to accumulate inside the cabin, cockpit, aft deck, and bridge when protective coverings are used and the boat is underway.

Teak surfing, dragging and water-skiing within 20 feet of a moving watercraft can be fatal.

D

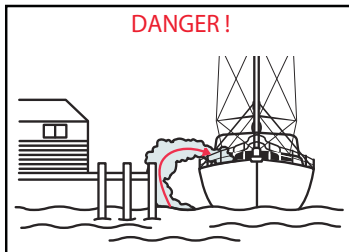

Moored to pier blocking exhaust!

Figure 4.3. Blocked hull exhaust outlets near a pier, dock, seawall, bulkhead or any other structure can cause excessive accumulation of Carbon Monoxide gas with the cabin areas of your boat. Be certain hull exhaust outlets are not blocked in any way.

A

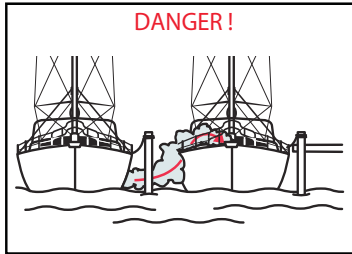

Exhaust from other vessels moored alongside!

Figure 4.4. Engine and generator exhaust from other vessels alongside your boat, while docked or anchored, can cause excessive accumulation of Carbon Monoxide gas within the cabin and cockpit areas of your boat. Be alert for exhaust from other vessels.

N

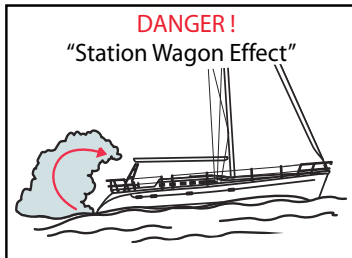

Caused by high bow angle!

Figure 4.5. Engine or generator exhaust from your boat while underway and operating with a high bow angle can cause excessive accumulation of Carbon Monoxide gas within the cabin and cockpit areas of your boat. Always provide adequate ventilation and redistribute the load to lower the boat angle.

G

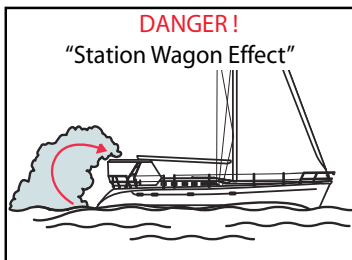

With protective coverings in place!

Figure 4.6. When protective weather coverings are in place, engine or generator exhaust from your boat, while docked and/or running, can cause excessive accumulation of Carbon Monoxide gas within the cabin and cockpit areas of your boat. Always provide adequate ventilation when the weather coverings are in place and either the engine or generator are running.

E

R

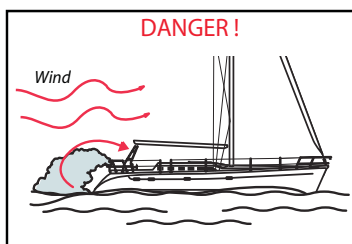

Figure 4.7. While underway or drifting slow speed can cause CO buildup, add a tailwind and this can intensify the effect.

“A working smoke alarm can save lives. It’s that simple and that important,”

If you would like to purchase additional CO detectors and receive a special purchase price, please contact our Customer Service Hotline at 800-771-5556,

On the next couple of pages we will review some of the CO hazards.

4.2.10 Carbon Monoxide Review

Everyone is at risk for Carbon Monoxide poisoning! Particularly sensitive are children, pregnant women, the elderly, and people with lung disease, heart disease, or anemia!

WHY? Because Carbon Monoxide is an odorless, colorless gas that prevents the blood from carrying oxygen to the vital organs. CO (Carbon Monoxide) is 200 times more likely to replace oxygen in the blood.

Check the symptoms of Carbon Monoxide poisoning in this chapter (4.2.4) again right now, so you will be able to recognize these symptoms should they ever arise.

! DANGER !

Mild Exposure	100 – 400 PPM (parts per million)	causes headaches and fatigue resembling the flu.
Medium exposure	400 – 800 PPM	causes severe headaches, drowsiness, nausea, and rapid heart rate.
Extreme exposure	over 800 PPM	results in unconsciousness, convulsions, heart or respiratory failure, and death.

Many reported cases of Carbon Monoxide poisoning determined that while victims are aware they are not well, they become so disoriented, they are unable to save themselves by either exiting the building or calling for assistance. Also, children and pets may be affected first.

Carbon Monoxide gas is produced when any type of fuel is incompletely burned. Gasoline engines and fuel burning appliances (furnace, fireplace, oven, stove, water heater, etc.) also, space heaters, gas, and charcoal grills produce CO.

Extended operation of unvented fuel burning appliances (range, oven, fireplace, etc.) can build up high CO levels.

! CAUTION !

This alarm will only indicate the presence of Carbon Monoxide gas at the sensor. Carbon Monoxide gas may be present in other areas.

! WARNING !

To reduce the risk of Carbon Monoxide poisoning, test the alarm’s operation after the boat has been in storage, before each trip, and once a week during use.

- DO NOT attempt to test the alarm by any other means than by using the Test/Reset button.
- DO NOT attempt to produce CO to test the alarm. The Test/Reset button tests all functions of the alarm and is the only safe way to be sure the alarm is working properly.

Once again, here and now, check in the DC Electric chapter on the operation of your CO detector. Learn how to use it, how it works, what the alarm signals are, and what your response should be.

! DANGER !

Actuation of your CO alarm indicates the presence of Carbon Monoxide (CO) which will KILL YOU! If the alarm sounds:

1. Press the Reset/Silence button.
2. Call Emergency Services: Write the number here _____.
3. Immediately move to fresh air, outdoors, or to an open window or door. Do a head count to check that all persons are accounted for. Do not re-enter the premises nor move away from an open door or window until the emergency responders have arrived, the premises have been aired out, and your alarm remains in its normal operation.
4. After following steps 1, 2, and 3, if your alarm reactivates in a 24 hour period, repeat steps 1 – 3 and call a qualified appliance technician:
Write the number here _____

Where to Install Alarms:

- For minimum protection, CO alarms should be installed near all sleeping areas.
- For maximum protection, CO alarms should be installed in all sleeping areas.
- Where not to Install Alarms:
 - Not behind furniture, drapes, closets, or areas that will block air flow to the alarm.
 - Not within 12 inches of window openings, exterior doors, heating or return air vents, or any other drafty areas.
 - The alarm should not be located within 5 (1.5 m) feet of any cooking appliance.
 - For information on taking care of your CO alarm, see the Maintenance chapter of this manual.

Limitations of the CO alarm:

Carbon Monoxide alarms will not work without power. Some examples causing no alarm power are: A blown or missing fuse, broken wire, faulty connection, circuit breaker tripped, or a discharged battery.

This alarm will only detect the presence of CO gas at the sensor. Carbon Monoxide gas may be present in other areas.

Carbon Monoxide alarms may not be heard. The alarm loudness is designed to meet or exceed the regulatory standards. However, the alarm may not be heard if alarms are located in remote locations or behind closed doors. The alarm may not be heard by persons who are hard of hearing, have consumed alcoholic beverages, taken prescription or non-prescription medication, or illegal drugs.

This alarm is designed to detect Carbon Monoxide from any source of combustion. It is not designed to detect smoke, fire, or any other gasses. The alarm may not sound at low Carbon Monoxide levels. This product is intended for use in ordinary indoor locations of living spaces. It is not designed to measure compliance with Occupational Safety Health Administration (OSHA) commercial or industrial standards. Individuals with medical problems may consider using warning devices which provide audible and visual signals for levels under 30 PPM.

How else to protect your family from Carbon Monoxide:

Ensure alarms are installed properly. Carefully read and follow ALL the instructions in this manual. Test your unit every week. Alarms that do not work, do not alert you to the presence of Carbon Monoxide.

Make regular visual inspections of all fuel burning equipment including gas water heaters, kitchen gas stoves, space heaters, gas dryers, or other pilots. Check the color of the flame! The color should be blue.

Make regular visual inspections of the engine and generator exhaust systems. Cracked exhaust systems can allow Carbon Monoxide to enter the living area.

Professionally maintain your engine and generator. Although all gas engines and generators produce Carbon Monoxide, a poorly tuned engine and generator will produce greater amounts of Carbon Monoxide.

4.3 Other Dangers

4.3.1 Weather

Storms rarely appear without advanced notice. Check the weather forecast before you begin a day of boating. Be aware, however, that weather conditions can change rapidly. If you have a marine radio, listen to the weather reports issued by the U.S. Coast Guard and others. If you have a portable radio, keep it tuned to a station broadcasting frequent weather reports. Many boating clubs fly weather signals. Learn to recognize these signals and listen to your local forecasts before leaving port.

Your surroundings can also be a good indicator of changing weather conditions. Watch for changes in wind direction or cloud formations. There is no substitute for a good understanding of weather conditions and what to do when the weather takes a turn for the worse.

Page 4.15 will give you a look at the dangers of Lightning strikes, with an overview of your protection area.

Other steps to follow to weather a storm include:

- Ensure all passengers have on their PFD's.
- Secure all loose gear.

- Reduce your speed. Keep enough power to head into the waves at an angle. Avoid taking waves over the bow. If wind and waves come from astern, adjust your power to keep waves over the stern.
- Position passengers so that the weight will best keep the boat stable. It is advisable for passengers to keep weight low and as close as possible to the centerline of the boat.
- Drop a sea anchor over the stern to maintain the bow into the seas. If you do not have a sea anchor aboard, use a canvas bucket, tackle box, or other object that will work like an anchor.
- Radar reflectors, if installed on your boat, should be 18 inches diagonally. They should be placed 12 feet above the waterline. Otherwise, a boat with radar may have trouble “seeing” your boat.



Never attach tow line to deck cleat or anchor windlass. Cleat or windlass may pull free from deck and cause serious personal injury or property damage.

4.3.2 Fog

You can judge the likelihood of fog formation by periodically measuring the air temperature and the dew point temperature. If the difference between these two temperatures is small, fog is likely to develop.

Foggy conditions include mist, snowstorm, or heavy rain.

Avoid operation in such weather, especially if your boat is not equipped with radar or other

4.3.3 Remember these guidelines:

- Unless your boat is well equipped with charts, head for shore at the first sign of fog and wait until conditions improve. If you have charts on board, take bearings as fog sets in, mark your position, and continue to log your course and speed.
- Make sure all persons on board have put on their personal flotation devices (PFDs). If your boat has sounding equipment, take soundings regularly and match them with known depths on your charts.

- Station a person forward in the boat as a lookout.
- Reduce your speed. From time to time, stop engines and listen for other fog signals.
- Sound the horn or bell at approximately 2 minute intervals.
- If there is any doubt about continuing your excursion, anchor. Listen for other fog signals while continuing to sound your fog horn.

4.3.4 Drugs and Alcohol

Drugs and alcohol affect a person’s ability to make sound judgments and react quickly. As a responsible boater, you will refrain from using drugs or alcohol (singly or combined) while operating your boat. Operation of motorized vessels while under the influence carries a significant penalty. Drugs and alcohol decrease your reaction time, impair your judgment, and inhibit your ability to safely operate your boat.

4.3.5 Collision

If a serious collision occurs, first check the persons on board for injuries. Then inspect the boat to determine the extent of the damage.

Prepare to help the other craft unless your boat or its passengers are in danger.

Prepare to help the other craft if your bow penetrated the other boat or its passengers are in danger.

If the bow of the other boat penetrated your boat’s hull, prepare to plug the fracture once the boats are separate.

4.3.6 Running Aground

If your boat runs aground, check everyone for injury and inspect damage to the boat or propellers. If lightly grounded, shift weight of passengers or gear to heel the boat while reversing engines. If towing becomes necessary, do not attach towline to deck cleats. These are not designed to take full load of the boat. We recommend using a commercial towing service.

4.3.7 Swamped or Capsized Boat

If your boat becomes swamped or capsized, put on a PFD immediately and set off a distress signal. Chances

are good a capsized boat will stay afloat. For this reason, stay with the boat. Do not leave the boat or try to swim to shore except under extreme conditions. A capsized boat is easier to see than a swimmer, and shore may be further away than it appears.

4.3.8 Falling Overboard

One of the most frightening emergencies that can occur aboard a boat is a crew member or yourself falling overboard. Although “man overboard” or “MOB” drills have been a part of boating safety for decades, they have been largely overlooked by many responsible boat owners.

Just as important as acquiring the knowledge to rescue a person is the ability to help yourself if you are the person overboard. Be sure and refer to your “Chapman Piloting”, “Seamanship and Boat Handling” manual supplied with your new boat. It is packed with useful and essential safety and emergency procedures to ensure you have a safe and happy boating experience.

We have the utmost interest in your safety. Therefore, we have provided a means of re-boarding the boat should you or a crew member fall overboard. On the transom, we have added steps to aid you in re-boarding. If your boat is equipped with a swim platform, there is a ladder attached to the platform which extends into the water.

4.3.9 Hypothermia

If a person falls overboard, hypothermia may be an immediate concern. Hypothermia means a person’s body loses heat to the water faster than the body can replace it. If not rescued, the person will become exhausted and likely drown. In general, the colder the water, the shorter the time for survival. PFDs will increase survival time because they provide insulation.

Water Temperature	Exhaustion or Unconsciousness	Expected Time of Survival
32.5	Under 15 min	Under 15 to 45 min
32.5 – 40	15 – 30 min	30 – 90 min
40 – 50	30 – 60 min	1 – 3 hrs
50 – 60	1 – 2 hrs	2 – 4 hrs
60 – 70	2 – 3 hrs	2 – 4 hrs
70 – 80	3 – 12 hrs	3 hrs – indefinite
Over 80	Indefinite	Indefinite

4.4 Fire



A fire aboard your boat is serious. Explosion is possible. Respond immediately. Develop a fire response plan.

4.4.1 Fire

Every boater should develop a fire response plan to determine what kind of fire (fuel, electrical, etc.) might break out, where it might break out, and the best way to react. Having a plan and, is possible, assigning responsibilities to others results in quicker decisions and quicker reactions.

Important: Everyone on board should know where a fire extinguisher is and how to operate it.

Any fire requires stopping the engines immediately.

If the fire is in the engine compartment, shut off the bilge blower immediately. Do not open the hatch to the engine compartment. The fire will flare up as the fresh air supply increases suddenly.

Keep the fire downwind if possible. If the fire is aft, head into the wind.

Have all persons on board put on their personal flotation devices (PFDs).

If you can get at the fire, aim the fire extinguisher at the base of the flames and use a sweeping action to put out the fire.

If the fire gets out of control, make a distress signal and call for help on the radio.

Deciding whether to stay with the boat or abandon ship will be difficult. If the decision is to abandon ship, all persons on board should jump overboard and swim a safe distance away from the burning boat.

4.5 Distress Signals

4.5.1 Mayday

If you have a VHF radio, heed storm warnings and answer any distress calls from other boats. The word "MAYDAY" spoken three times is the international signal of distress. Monitor marine radio channel 16, which is reserved for emergency and safety messages. You can also use this channel to contact the Coast Guard or other boaters if you have trouble.

Never send a "MAYDAY" message unless there is a serious emergency and you are in need of immediately assistance.

4.5.2 Visual Distress Signals

The U.S. Coast Guard requires that all boats operating on U.S. Coastal Waters have visual distress signal equipment on board. In general, coastal waters include all waters except rivers, streams, and inland lakes. The Great Lakes are considered coastal waters, as is a river mouth more than two miles wide. Boats owned in the United States and operating on the high seas must also carry visual distress signal equipment.

Visual distress equipment must be in serviceable condition and stowed in a readily accessible location. Equipment having a date showing useful service life must be within the specified usage date shown. Both pyrotechnic and non-pyrotechnic equipment must be U.S. Coast Guard approved.

Pyrotechnic U.S. Coast Guard approved visual distress signals and associated equipment include: Red flares, handheld or aerial Orange smoke, hand held or floating Launchers for aerial red meteor or parachute flares. Non-pyrotechnic equipment includes an orange distress flag, dye markers, and an electric distress light.

No single signaling device is ideal under all conditions for all purposes. Consider carrying various types of equipment. Careful selection and proper stowage of visual distress equipment is very important. If young children are frequently aboard, you should select devices with packages which children, but not adults, will find difficult to open.

Other helpful publications available from the U. S. Coast Guard include "Aids to Navigation" (U.S. Coast Guard pamphlet #123), which explains the significance of various lights and buoys, the "Boating Safety Training Manual", and "Federal Requirements for Recreational Boats". Check with your local Coast Guard Station, your new dealer, or a local marina about navigational aids unique to your area.

4.5.3 Running and Navigation Lights

Your boat must have running and navigation lights for safe operation after dark. Observe all navigation rules for meeting and passing. Do not run at high speeds during night operation. Always use common sense and good judgment.

Operating at night can present some special challenges. Not only is your depth perception lessened, bright lights on the shore can cast misleading reflections on the water and if you wear glasses, or worse yet, bifocals, you simply don't see as well at night as you do during the day. It is not only important that you be able to identify other vessels operating in your proximity, it is equally important that other vessels see you. Most recreational vessels are less than 30 feet in length and, according to "The Rules of the Road", shall be equipped with navigation lights. These lights not only have a certain arc through which they can be seen but must be seen from a minimum distance. Fig. 4.8, on page 4.14 will show you the following lighting requirements for recreational vessels both less than 12 meters in length (approximately 39.4'), and over 12 meters in length to 20 meters (65')

Light	Arc	Color	Visible Range
Masthead Light	225	Wht	2
Starboard	112.5	Grn	1
Port Sidelight	112.5	Red	1
Sternlight	135	Wht	2

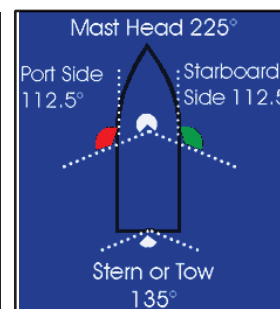

The arc of the lights and color allows you to determine the direction a vessel is moving. How good are your lights? You should test them to see how visible you might be at night. Whether on a trailer or at the marina, switch on your lights and see how well they can be seen. Walk away from the boat or row away, if you are at anchor or at a mooring, and see how visible the lights are as you move further away. How easy are they to see against the background of lights on shore?

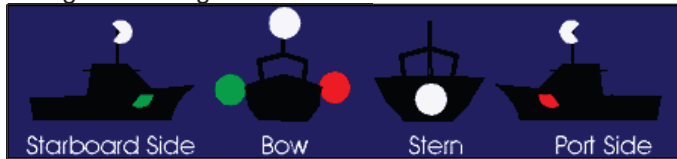

by 1-3 degrees, you should then see only one light. If you still see two lights, an approaching vessel won't be able to tell which direction you are going.

When boating at night, remember the following: "When two lights you see ahead, turn your helm and show your red."

4.5.4 Sound Signaling Device

Your boat is provided with a horn which conforms with U.S. Coast Guard requirements for boats of this size. All class A boats are recommended to carry a hand, mouth, or whistle, as well as a power operated horn. The device

Vessel	Notes	Lights	Less than 12 meters (39ft.)	12 (39ft.) meters to less than 20 (65 ft.) meters
Power	This includes sailing vessels under power and motor sailing	White Masthead Light	2 NM (3.7 km) see note	3 NM (5.6 km)
		Sidelights or combination lights	1 NM (1.9 km)	2 NM (3.7 km)
		sternlight	2 NM (3.7 km) see note	2 NM (3.7 km)
Sail	Sailing Vessels under sail alone	Sidelights or combination lights	1 NM (1.9 km)	2 NM (3.7 km)
		sternlight	2 NM (3.7 km) see note	2 NM (3.7 km)

Let's say that your stern light, for some reason, can only be seen for 1/2 mile. You are underway at 8 knots and a large ship is approaching at 15 knots. The ship is only 4 minutes away from collision with you. By the time the ship "might" see you, identify the light and decide on the reaction that should be taken, it is too late. A ship traveling at 15 knots may take miles to stop. Look at the stern light again, as you move from the stern toward the bow. Does the stern light "disappear" as the sidelight "appears"? The stern light should disappear and sidelight appear at 22.5 degrees abaft the beam. If you don't see the green starboard sidelight or the red port sidelight when the stern light disappears, there is a problem with the arc of one or all of these lights. This means that if another boat were approaching you at the angle where no lights are seen, there is increase risk of collision.

should be used to promote safe passing, as well as a warning to other vessels in fog, or confined areas, or as a signal to operators of locks or drawbridges. Following are standard whistle signals:

One Prolonged Blast	Warning Signal
One Short Blast	Pass on my port side
Two Short Blasts	Pass on my starboard side
Three Short Blasts	Engines in Reverse
Five or More Blasts	Danger Signal

Fig. 4.8

You should also check to make sure that your masthead light disappears at the same time each sidelight disappears and they both disappear when the stern light appears.

Check your sidelights from dead ahead. You should see both red and green. However, by moving toward one side

Lightning Storm Warning

All whip antennas should be tied during the storm, unless they are part of the Lightning Protection System.

Precautions during lightning storms:

- * Occupants should take shelter inside a closed area of the boat, *i.e.* below deck!
- * Occupants should not have any body parts in the water!
- * Avoid contact with components of the Lightning Protection System or any type of metal objects!

See the protection zone illustration below.

Should lightning strike the boat:

- * Wait until the threat of the storm has passed then:
- * Inspect all electronics, electric gear, compass, and the Lightning Protection System for possible damage!
- * Recalibrate equipment if necessary!

Failure to follow the precautions may result in severe injury or death!

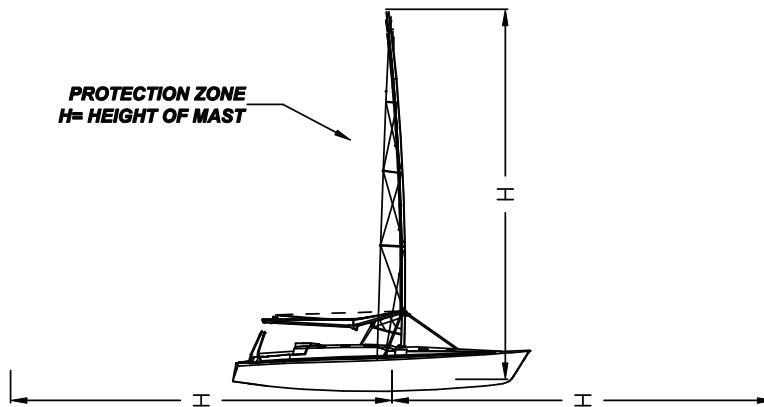

Lightning photo courtesy of: National Oceanic and Atmospheric Administration/Department of Commerce

Hunter 50cc DIMENSIONS, CAPACITIES

HULL LENGTH	47.92 ft.	14.61 m.
LENGTH OVERALL (INCLUDES BOW ROLLER)	49.91 ft.	15.21 m.
LENGTH OF WATERLINE (LWL)	43.92 ft.	13.39 m.
BEAM (MAX)(without rubrail)	14.33 ft.	4.37 m.
BEAM (MAX)(with rubrail)	14.76 ft.	4.50 m.
DRAFT		
* SHOAL	5.50 ft.	1.68 m.
* DEEP	7.00 ft.	2.13 m.
DISPLACEMENT		
* SHOAL	36945.85 lbs.	16758.36 Kg.
* DEEP	35661.85 lbs.	16175.94 Kg.
BALLAST (LEAD KEEL)		
* SHOAL	12500.00 lbs.	5669.91 Kg.
* DEEP	11216.00 lbs.	5087.49 Kg.
MAST HEIGHT (FROM WATERLINE)		
* STANDARD	63.33 ft.	19.30 m.
* FURLING	63.33 ft.	19.30 m.
* FURLING TALL	68.50 ft.	20.88 m.
SAIL AREA		
* STANDARD/ACTUAL	1277.13 sq. ft.	118.65 sq. m.
* V-Batten FURLING/ACTUAL	1161.41 sq. ft.	107.90 sq. m.
* FURLING/ACTUAL	1069.85 sq. ft.	99.39 sq. m.
* FURLING TALL/ACTUAL	1258.65 sq. ft.	116.93 sq. m.
* STANDARD/TRIANGLE	1013.90 sq. ft.	94.19 sq. m.
* V-Batten FURLING/TRIANGLE	1050.80 sq. ft.	97.62 sq. m.
* STAYSAIL/TRIANGLE	228.85 sq. ft.	21.26 sq. m.
* STAYSAIL/ACTUAL	200.05 sq. ft.	18.59 sq. m.
SA/DISP		
* STANDARD/ACTUAL	31.20	
* V-Batten FURLING/ACTUAL	28.38	
* STANDARD/TRIANGLE	14.62	
* FURLING/TRIANGLE	15.16	
DISPLACEMENT LENGTH RATIO (DLR)	194.73	
SAILPLAN		
I	54.61 ft.	16.65 m.
I2	41.30 ft.	12.59 m.
J	16.50 ft.	5.03 m.
J2	11.08 ft.	3.38 m.
P		
* STANDARD	51.60 ft.	15.73 m.
* FURLING	50.61 ft.	15.42 m.
* FURLING TALL	55.78 ft.	17.00 m.
E		
* STANDARD	21.83 ft.	6.65 m.
* FURLING	23.72 ft.	7.23 m.
* FURLING TALL	23.72 ft.	7.23 m.
FUEL TANK CAPACITY		
	162.00 gal.	613 liters.
WATER CAPACITY		
	194.00 gal.	734 liters.
WATER HEATER		
	39.00 gal.	148 liters.
HOLDING TANK CAPACITY		
	52.00 gal.	197 liters.
LPG TANK CAPACITY (SPARE OPT)		
	2 X 10 lbs.	2 X 4.5 liters.
INBOARD ENGINE		
* STANDARD	75 hp	56.25 kw.
* OPTION	110 hp	82.50 Kw.

50cc INTERIOR ARRANGEMENT

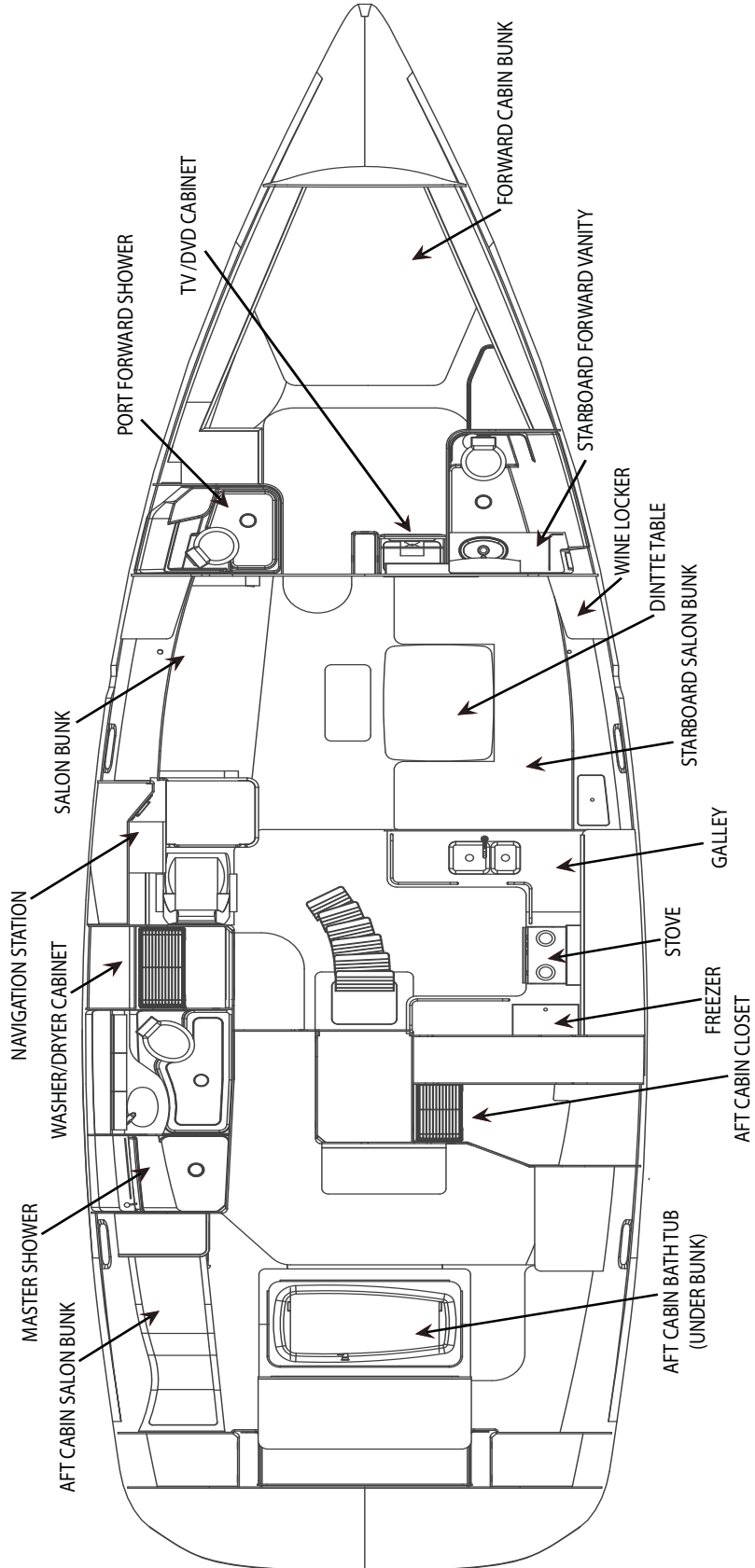

50cc DECK HARDWARE LIST

Item	Description
1	Bow roller Assembly
2	Bow rail with 4 stanchion bases
3	Anchor well lid
4	Bow light (Green)
5	Sail locker hatch (Size 60)
6	Mooring Cleat
7	Cutterstay chainplate (Option)
8	2 line stanchion with base
9	Size 54 Hatch (Smoked)
10	Stainless grab rail (3 legs)
11	Size 03 hatch (smoked)
12	2 line stanchion with base
13	Mast Step
14	Size 60 Hatch (Smoked)
15	Inner Chainplate
16	Deck Organizers
17	Jib Track Lead System
18	2 line stanchion with base
19	Size 30 Hatch (Smoked)
20	Stainless grabrail (4 legs)
21	Sheet stoppers
22	Mooring Cleat
23	Size 46 Winch
24	Gate Stanchion with base
25	Gate Stanchion with base
26	Size 54 Winch
27	Size 54 Winch
28	Sheet stopper (Headsail jib sheet)
29	Arch
30	Foot block
31	Standing block
32	Standing block
33	Starboard Aft facing stainless seating
34	Starboard stern rail seat
35	Mooring Cleat
36	Transom center stainless stern rail seat
37	Transom ladder
38	Stern light
39	Mooring Cleat
40	Port stern rail seat
41	Port aft facing stainless seating

Item	Description
42	Aft cabin hatch (Size 54)
43	Standing block
44	2 line stanchion with base
45	Foot block
46	Standing block (Dual mainsheet control)
47	Size 54 Winch
48	Sheet stopper (Staysail jib sheet)
49	Size 54 Winch
50	Gate Stanchion with base
51	Steering pedestal
52	Cockpit table
53	Gate Stanchion with base
54	Size 46 Winch
55	Sheet stoppers
56	Mooring Cleat
57	Stainless grab rail (4 legs)
58	Size 30 Hatch (Smoked)
59	2 line stanchion with base
60	Jib Track Lead System
61	Deck Organizers
62	Inner Chainplate
63	Mooring Cleat
64	2 line stanchion with base
65	Size 03 hatch (smoked)
66	Self-Tacking Jib Track Assembly
67	Stainless grab rail (3 legs)
68	Size 54 Hatch (Smoked)
69	2 line stanchion with base
70	Mooring Cleat
71	Port bow light
72	Transom storage locker
73	Emergency tiller access cover
74	Transom LPG locker
75	Aft cabin hatch (Size 54)
76	Engine blower vent
77	Manual bilge pump thru deck fitting
78	Cockpit scupper drain access cover
79	Cockpit steering wheel
80	Aft waste tank pump out fitting
81	Fuel fill fitting
82	Forward waste tank pump out fitting

50cc DECK HARDWARE ARRANGEMENT

CAUTION

Always be aware of your surroundings when on the deck!

Area's of the deck may be very slippery when wet.

This could result in a fall, or a "Man Overboard"!

Be sure and review the procedures for rescue of a man overboard, and have a plan in place!

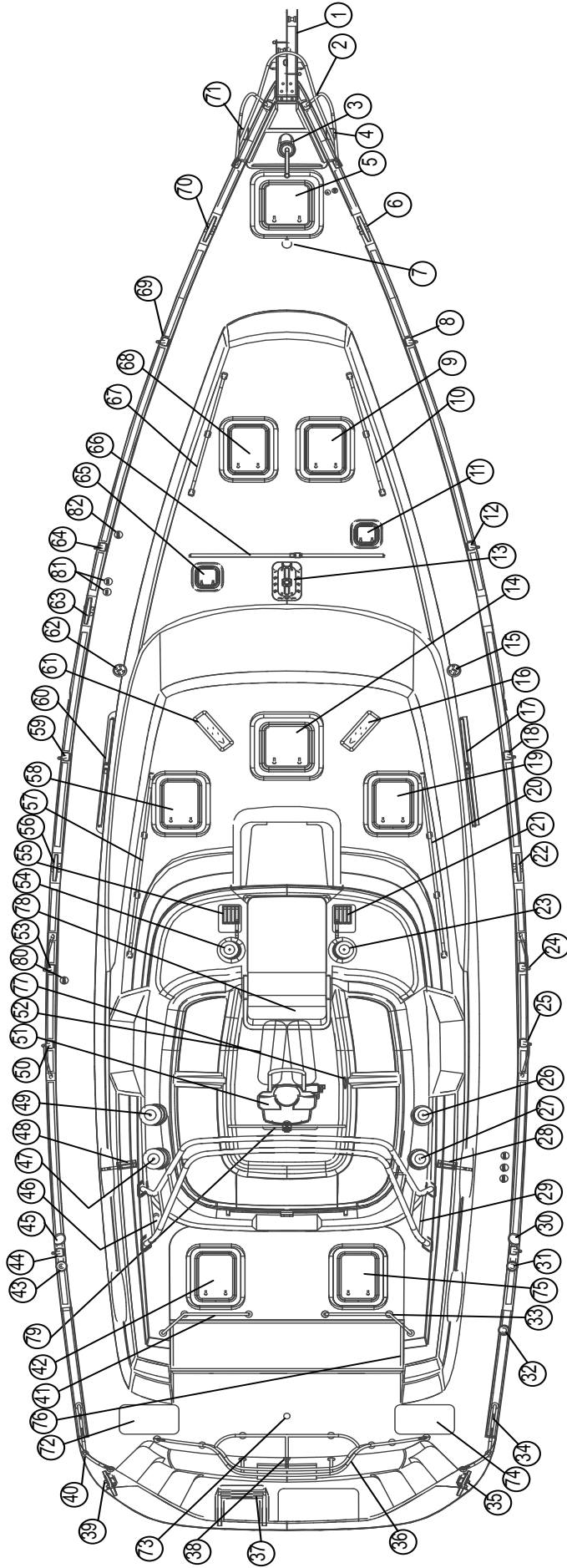



HUNTER®

MARINE CORPORATION

AN EMPLOYEE OWNERSHIP COMPANY

We Go The Distance

Chapter 5

Fuel Systems

Hunter 50cc



FUEL SAFETY CHECKLIST FOR BOARDING

This fuel safety checklist is designed to be used as a quick reference to minimize the risks associated with fuel hazards. You should refer to this checklist every time you board your boat. Read your owners manual so that you have a full understanding of the fuel system on your boat.

Before approaching your boat, extinguish all smoking materials and make certain there are no other sources of possible ignition near your boat.

Approach your boat alone to make the initial inspection. Have your guests and crew standby a safe distance away.

From the dock, visually inspect your boat for any fuel leaks from the deck fills or hull vents and take notice if there is any odor of fuel.

Once aboard, open the cabin door and sniff at the doorway then inside the cabin for fuel odor.

Open the engine compartment hatch and sniff for fuel odor.

Inspect the engine compartment and all bilge compartments for fuel leaks and sniff for fuel odor.

If there are any signs of fuel leakage, either visually or by odor, open doors, hatches, and windows. Evacuate the boat and inform the dock master. Have an authorized service technician inspect your boat.

If no signs of fuel are present, board your guests and crew.

Run exhaust blowers for five minutes before starting the engines or generator.

Always be aware of the hazards associated with fuel and practice good common sense.

"HAPPY AND SAFE BOATING" from the Hunter Team

Fuel Systems

The fuel systems aboard your Hunter yacht consists of the following components or sub-systems.

- Fuel Tank
- Fuel Fill
- Fuel Vent
- Fuel
- Lines
- Fuel Filters
- LPG (Liquefied Petroleum Gas) System

5.1 Fuel Tanks

Your boat is equipped with two fuel tanks, having a total capacity of 162 gallons (612 Liters). In the main cabin port side under the bunk.

The tanks are filled through a fuel fill (5.2), on the port forward amidship on deck of the boat.

If your boat has a metal or aluminum tank installed, then the fuel tank should be inspected for signs of leaks, corrosion, and/or pitting at least once a year. Corrosion normally appears as a white, chalky, or flaky substance on the surface of the tank. Sometimes, it also appears as pitting or small pockets of missing aluminum. Another indication of corrosion is bubbles on the paint that coats the tank. If any of these conditions are present, have an authorized service technician inspect the tank immediately. If a leak is found, turn off battery switches and disconnect shore power (See Connecting & Disconnecting Shore Power, AC Electrical System), which explains the proper way to disconnect and disable any possible source of ignition). Contact your dealer or Customer Service immediately.

5.1.1 Fuel Tank Capacity Monitoring

The fuel tank is equipped with a fuel level sending unit, which provides an electrical signal to the multi-purpose display located at the helm. The monitor (Fig. 5.1) also handles engine monitoring and general boat data from all connected items to this unit, and will allow the same to be displayed in a variety of formats.

This monitoring system also features a touch screen call up that is easily read at day or night.

Be sure and review the documentation for this monitor supplied to you by the manufacturer.

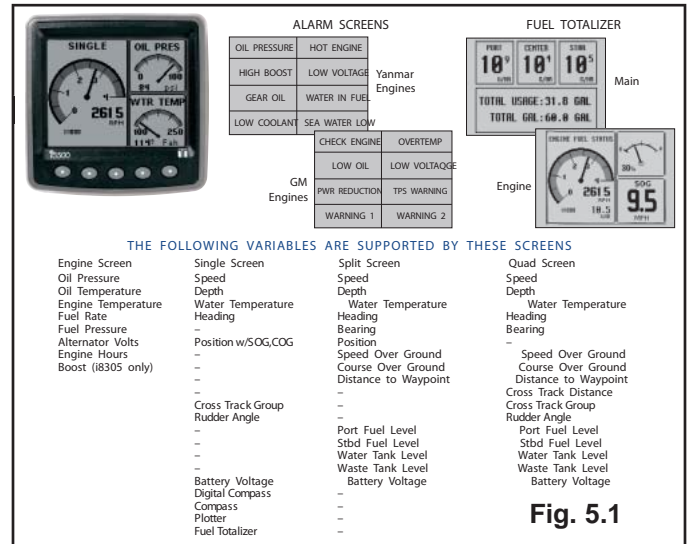

Fig. 5.1

5.1.1 Fuel Tank Grounding System

The fuel tank and fuel fill on your boat are electrically grounded to the engine negative. (see the DC Electrical chapter). This grounding system is designed to prevent the discharge of static electricity when fueling your boat. An authorized service technician should inspect this system at least once each year.



Fig. 5.2

5.1.2 Fuel Gauge

The fuel gauge as shown in Fig. 5.1 is located at the helm, and is the indicator of the fuel level in your tank. Visually inspect the reading against what is showing in the tank to see that the gauge is operational.



Never enter the engine room without proper ventilation first. A spark caused by power tools or lighting equipment could result in fire or explosion which

could cause personal injury or death.



WARNING

Fuel leaking from any part of the fuel system can lead to fire and explosion that can cause serious bodily injury or death. Inspect system before fueling.



CAUTION

Using the wrong type of fuel will result in severe damage to the engines. Refer to your owner's manual for fuel recommendations.



DANGER

Leaking fuel is a fire and explosion hazard. Personal injury or death could occur.

5.1.3 Fuel Tank Fill & Vent

The fuel tank fill fittings are located on the port forward side of amidship. The fuel tank also has a hull vent fitting. This fitting is also located on the port side near the fuel fill. You can see the fill in detail in Fig. 5.2, on page 5.3.

The fuel tank vent serves as a pressure / vacuum release and a safety overflow. The vent is a thru hull fitting with a flame arrestor, so it is imperative that you keep the screens clear and in excellent repair. Replace the screen immediately if it becomes damaged or displaced. Periodically check the vent to see that it is not clogged.

The fuel fill and fuel vent hoses, fittings, and connections should be inspected for leaks and signs of dry rot or swelling at least once a year. If any of these conditions are present, have an authorized service technician inspect the fuel system immediately. If a leak is found, turn off battery switches, disconnect shore power, and disable any possible source of ignition. Contact your dealer or Customer Service immediately.



DANGER

The use of any hose other than the USCG Type A1 or A2 could result in fuel leakage. Leaking fuel is a fire and explosion hazard. Personal injury or death could result.

5.2 Fuel Supply Lines and Hoses

If any fuel fill or vent hose's are in need of replacement, ensure that only USCG Type A1 or A2 are used. The engine has a fuel supply hose that runs from the pickup tube in the fuel tank to the fuel water separator (commonly referred to as the fuel filter), then from the filter to the engine. Also, the engine has a fuel return hose that runs from the engine back to the fuel tank. If your boat has a generator, the generator will have somewhat the same setup, with the supply and return hose. The fuel supply lines or hoses, fitting, and connections should be inspected often for leaks and signs of wear, dry rot, chafing, or swelling. A good way to inspect the fuel hoses is to run your hand along the length of the hose including the fittings. Leaks will be revealed as wet spots on your hand. If any evidence of hose deterioration is present, have a qualified technician replace all the hoses with USCG Type A1 hoses immediately!

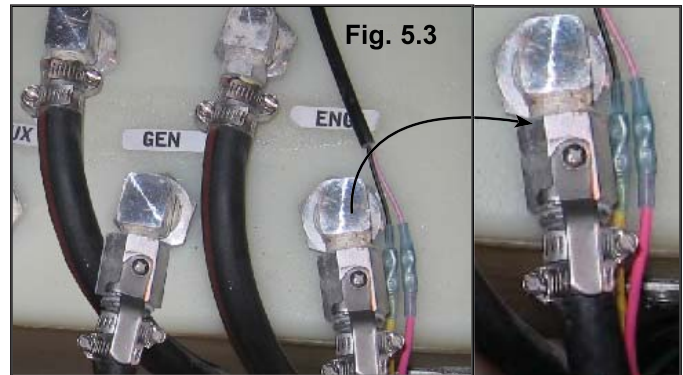

In Fig.5.3 you can see the fuel supply fittings. The photo inset shows the close-up of the fuel valve as an example.

Note: If a leak is found, turn off battery switches, disconnect shore power, and disable any source of ignition. Do not start your engines, the generator, or any devices that could create a spark. Contact your dealer or our Customer Service Department immediately! If hoses need to be replaced, make sure only USCG Type A1 are used.

5.2.1 Generator Fuel Supply Notice

In Fig. 5.4 we demonstrate the layout of your boat's fuel pick up lines in the fuel tank. See the Mechanical Arrangement Drawing in the Boating Safety chapter of this manual for more location information. In the image you can see the pick up for the generator is located higher than the engine pickup

This is a safety feature of your boat, to ensure that the generator never depletes the fuel to the engines.

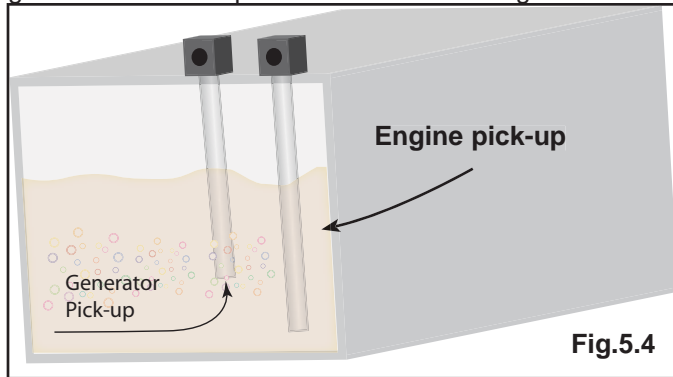

With two fuel tanks the boat is also required with valve for selecting which tank to draw fuel from. The valves are located in the first bilge compartment in the main salon. For fuel tank selection, by rotating both valve handles for the fuel supply and one for the return. Align with the placards that mark tank to use.

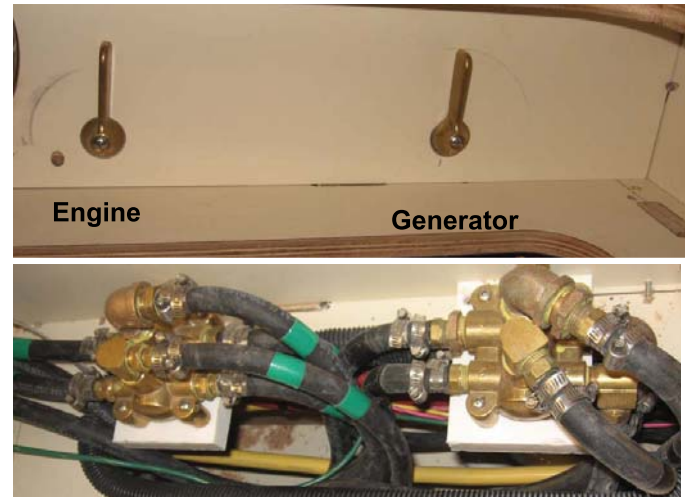

Fig. 5.6 Fuel tank selection control valve

5.3 Fuel Valves

Your boat has fuel shutoff valves located at the tank in the supply line route. These valves are used to start or stop the flow of fuel through the supply lines.

Note: Even if the fuel supply valves are closed, there may be fuel in the supply lines to the filters and engines (or generator). Disconnecting these fittings without properly bleeding the system of fuel could result in emptying the fuel filters and causing a fuel spill. Only a qualified technician should ever make repairs to your fuel system.

The fuel supply valves are the “ball type” valves. Turning the handle so it is perpendicular to the valve body shuts off the supply or return. Turning the handle so it is in line with the valve body opens the valve, as shown in Fig. 5.5.

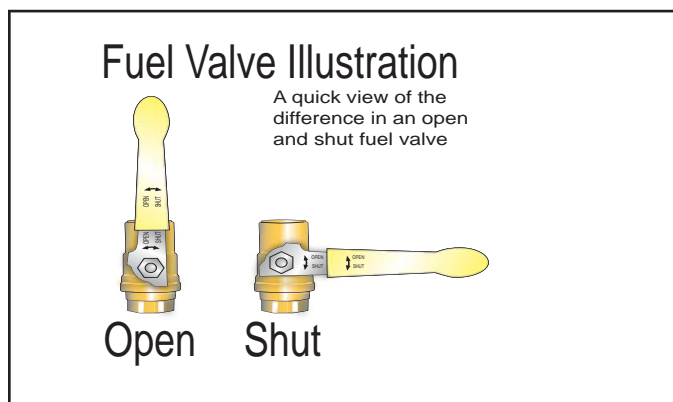

Fig. 5.5 Example of Fuel Supply Lines and Valves

Note: This configuration may not reflect the configuration of what your fuel valves are. This can be found in the Fuel System Arrangement at the end of this chapter.

5.4 Filters (Fuel Water Separators)

The fuel supplied to the engines or the generator (if so equipped) may contact impurities found in the fuel tanks or in the fuel from your supplier. If these impurities are not removed prior to starting the engine or generator, performance may be seriously affected. Removal of the fuel impurities is accomplished by external fuel filters.

5.4.1 Main Engine Filters

Each engine has a separate filter located away from the engine. Check the Fuel Arrangement illustration at the end of this chapter for the exact location of these filters.

An authorized service technician should replace all filters annually prior to spring launch. They may need more frequent replacement if you notice poor engine/generator performance due to contaminated fuel.

You will find an illustration for the Racor Fuel Water separator

rator in the following page (commonly referred to as the fuel filter). This will break down the components of the filter and their uses within the filter.

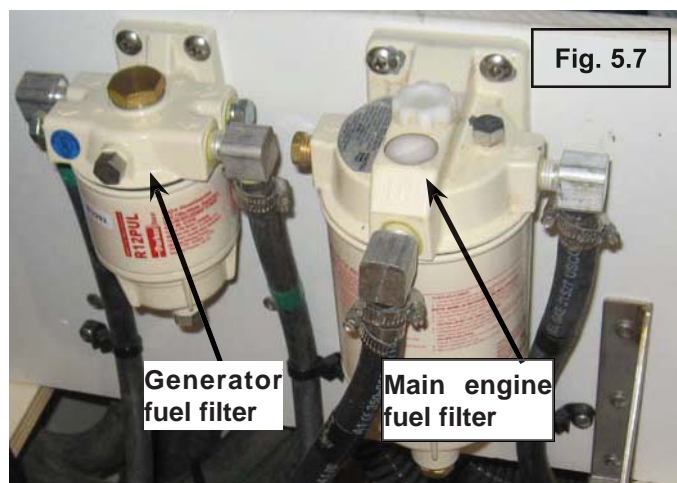

5.4.2 Generator Fuel Filter

Check your fuel system arrangement at the end of this chapter for the location of the Generator Filter (tagged). This is a fuel – water separator type filter.

To service the filter:

1. Make sure the engine is off.
2. Close shut-off valve between fuel tank and filter if applicable.
3. Open vent plug on mounting head with a ½” wrench.

Note: Do not leave drain open for very long as it will empty filter of all fuel.

4. When fuel is detected coming out of drain, close drain quickly.
5. Close vent plug and tighten snugly.
6. Open shut off valve.
Follow priming instructions.

Consult your owner’s packet for more information concerning this filter or for replacement parts.

5.4.3 Here are some general guidelines for fueling your boat:

! CAUTION !

Using the wrong type of fuel will result in severe damage to the engines. Refer to your owner’s manual for fuel recommendations.

! WARNING !

Fuel leaking from any part of the fuel system can lead to fire and explosion that can cause serious bodily injury or death. Inspect system before fueling.

Before fueling, check the fuel system for leaks. Check components for weakening, swelling, or corrosion. Immediately replace any leaking or defective components before operating an engine. Keep the tank as full as practical to reduce condensation and the accumulation of moisture in the fuel system. In warm and hot weather, allow for expansion of the fuel. A fuel tank may overflow when the fuel expands after being pumped from cool underground storage tanks or after fueling when air temperatures are cool (night and early morning).

5.4.4 Follow these procedures to fuel your boat:

- Safely and securely moor your boat to the dock.
- Turn off engine and generator.
- Turn main battery switches off to prevent sparks from electrical equipment (lights, blowers, pump, etc.)
- Disconnect shore power if connected.
- Put out all cigarettes, cigars, pipes, or other items that may produce a spark or flame.
- Ask guests to leave the boat during fueling.
- Remove cap from the fill pipe.
- Insert the fuel hose nozzle into the fill pipe. During fueling, maintain contact between the nozzle and the fill pipe.
- After pumping several gallons of fuel, inspect engine compartment for any signs of fuel leakage.
- Fill the tank completely, allowing space at the top of the tank for thermal expansion.

Fig. 5.7

A Quick Fuel Filter Reference

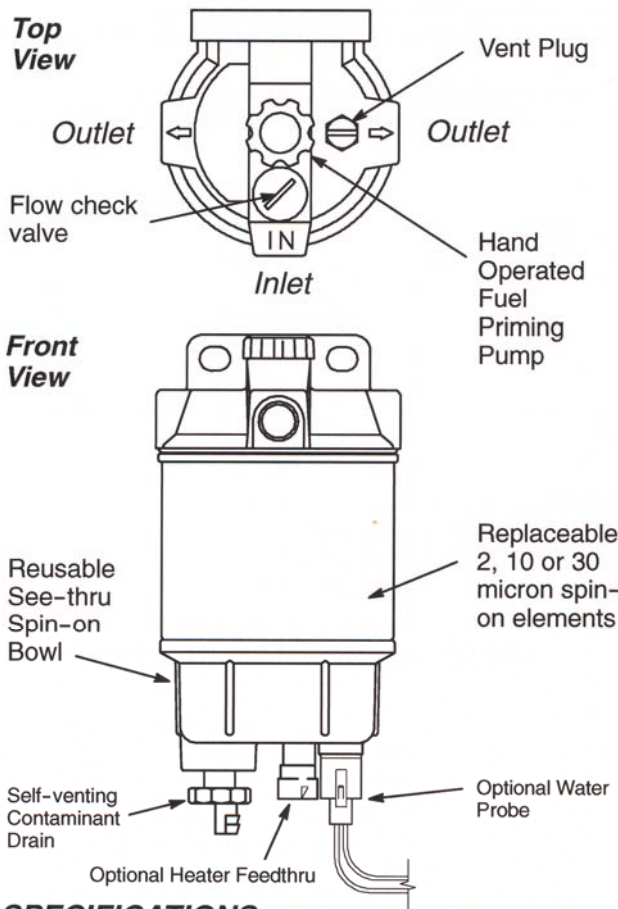

Racor's 215R, 230R, and 245R Fuel Filter/Water Separators are specifically designed to handle today's tough diesel filtration problems. These units feature a standard in-head fuel priming pump and are different from one another only in flow capacity and element size.

These units may be used on the suction (vacuum) side or pressure side (up to 30 PSI) of the fuel transfer pump. The die-cast aluminum mounting head features two outlets and one inlet for installation to most fuel systems. The fuel ports are standard SAEJ476 1/4" NPTF (tapered dryseal pipe thread). Many varieties of fittings are available from Racor or hardware dealers. (Fittings may not be supplied with this unit).

A vent plug is fitted to easily evacuate trapped air, making fuel priming an easy, no-mess experience.

Engines will benefit from near 100% water separation and fuel filtration with Racor's proprietary *Aquabloc™* water repelling media. The replaceable spin-on filter elements are available in 2, 10, and 30 micron ratings.

The reusable see-through contaminant collection bowl allows the operator to check contamination build-up at a glance. The contaminant drain is opened by rotating the knob counterclockwise (if facing the bowl's bottom side).

OPTIONAL FEATURES:

An available option is a water probe which alerts the operator when it's time to drain the bowl. (The probe must be used with a 12 or 24 vdc powered Water Detection Kit. See Accessories for available models). For use with diesel fuel systems, only.

A powerful 12 or 24 vdc 200 watt In-bowl heater option is available to quickly warm the element fuel thus providing easier starting and optimum operating efficiency in cold weather or climates. **Danger! Accessories are not intended for use with gasoline or flammable liquid applications.**

Additionally, a metal bowl is available for severe service, heavy duty, or marine applications. This bowl features a 3/8"NPT drain plug which may be replaced by a UL listed drain valve (refer to parts list).

For marine applications, specify Models: 215RMAM, 230RMAM or 245RMAM. *Note: Heaters may not be used with these models.*

PART NUMBER IDENTIFICATION

The example below illustrates how part numbers are constructed.

245R	M	P	12	2
215R =	Metal bowl.	In-bowl	In-bowl	Filter
15 GPH	(Omit if	Water	Fuel Heater:	Micron
230R =	not desired)	Probe.	12 vdc or	Rating:
30 GPH	Specify		24 vdc. Not	Specify
245R =	MAM for UL	(Omit	for marine	one:
45 GPH	Marine	if not	use. (Omit if	2, 10
	Models.	desired)	not desired)	or 30

SPECIFICATIONS

MODEL		215R	230R	245R
Maximum Flow Rate	GPH	15	30	45
	LPH	57	114	170
Replacement Element Series		R15	R20	R25
Fuel Ports (SAEJ476)	NPT	1/4"	1/4"	1/4"
Clean Pressure Drop	PSI	0.12	0.31	0.61
	kPa	0.82	2.14	4.21
Height	in.	8.3	9.0	10.5
	mm	211	229	267
Width	in.	4	4	4
	mm	102	102	102
Depth	in.	4	4	4
	mm	102	102	102
Weight, Dry	lbs.	1.8	2	2.2
	kgs.	.80	.90	1.0
Operating Temp.		- 40° / +255°F / - 40° / +121°C		

- Fill slowly near the top to avoid overflow.
- Remove nozzle after tank is full and replace fill cap.
- Make sure cap is tight.
- After fueling is complete, open all hatches, doors, and compartments.
- Visually check all fuel fittings, lines, and tanks for fuel leakage.
- Check all lines up to engines and generator. Smell for fumes.
- Correct any problem before you start the engines.
- Turn main battery switches on.
- Restart engines and restore boat to operating condition.

5.4.5 Bleeding the Fuel System

The fuel system has an automatic air bleeding device that purges air from the fuel system. No manual air bleeding is required for normal operation. Bleeding must be done if any fuel system maintenance has been performed (replacement of fuel filter, etc.) or if the engine does not start after several attempts.

5.4.6 Handling of Diesel Fuel

1. Water and dust in the fuel may cause engine failure. When fuel is stored, be sure that the inside of the storage container is clean and dry, and that the fuel is stored away from dirt or rain.
2. Keep the fuel container stationary for several hours to allow any dirt or water to settle to the bottom of the container. Use a pump to extract the clear, filtered fuel from the top of the container.

BEFORE YOU OPERATE THE ENGINE

Do not smoke until your boat is clear of the fuel dock.



Fuel vapors can explode. Do not smoke at the dock. Extinguish all flames, stove, and other ignition sources before you approach a fuel dock.



Explosive fuel vapors can become trapped in the lower portions of the boat. Close all hatch covers, windows, doors, and compartments while fueling your boat.

5.5 LPG (Liquefied Petroleum Gas) System

LPG (Liquefied Petroleum Gas) is a generic term to describe liquefied gasses consisting predominately of Propane (C3) and Butane (C4) hydrocarbons.

5.5.1 Hazards

Extremely flammable! These gasses readily form explosive air-vapor mixtures at ambient temperature. Vapor is heavier than air and may travel to remove sources of ignition (e.g. along drainage systems, into bilges, etc.).

Liquid from the tanks will generate large volumes of flammable vapor (approximately 250:1).

Cold burns (frostbite) will result from skin/eye contact with liquid from the tanks.

Liquid release or vapor pressure jets present a risk of serious damage to the eyes.

Abuse involving willful inhalation of very high concentrations of vapor, even for short periods, can produce unconsciousness or might prove fatal. Inhalation may cause irritation to the nose and throat, headache, nausea, vomiting, dizziness, and drowsiness.

Unconsciousness or asphyxiation may result in poorly ventilated or confined spaces.

5.5.2 First-Aid Measures

Eyes: Immediately flush eyes with plenty of cool water for at least 15 minutes. Hold eyelids apart while flushing to rinse entire surface of eye and lids with water. Get immediately medical attention.

Skin: In case of cold burns, immediately place affected area in warm water (41 degrees) and keep immersed until circulation returns. Get immediate medical advice.

Other requirements: Severe inhalation or overexposure

to this material may sensitize the heart to cat echo la mine-induced arrhythmia. Do not administer *cat echo la mine to overexposed individuals. Contact the Poisons Information Service and/or seek further medical advice.

*(Cat echo la mine are chemical compounds derived from the amino and tyrosine that act as hormones or neurotransmitters.) "Wikipedia Encyclopedia"

5.5.3 Fire-Fighting Measures

Activate emergency systems and/or sound the alarm. Call the Fire Department. Evacuate all persons from the area.

Ensure an escape route is always available from any fire. If it is safe to do so, close the container valves). Allow any gas-fueled fire to burn out. If unable to cut off supply of gas, allow it to burn.

Keep LPG cylinders or tanks cool, as pressurized containers will explode if subjected to high temperatures.

Small LPG fires can be attacked with dry powder fire extinguishers, provided the fuel supply can be turned off after the fire is extinguished.

5.5.4 Accidental Release Measures

As these substances have a very low flash point, any spillage or leak is a severe fire and/or explosion hazard.

If a leak has not ignited, stop gas flow at container, eliminate all sources of ignition, and evacuate all persons. Stay upwind of release. Inform emergency services.

Liquid leaks generate large volumes of flammable vapor, heavier than air, which may travel to remove sources of ignition (e.g. along drainage systems).

Where appropriate, use water spray to disperse the gas or vapor.

Vapor may collect in any confined space.

If spillage has occurred in a confined space, ensure adequate ventilation and check that a safe, breathable atmosphere is present before entry.

Do not enter a vapor cloud. Only trained specialized individuals should attempt to enter a vapor cloud.

Wear protective clothing. See 5.5.7

In the event of a major leak, contact the appropriate authorities.

Small quantities of spilled liquid may be allowed to evaporate. Vapor should be dispersed by effective ventilation.

5.5.5 Handling and Storage

Store and use only in equipment/containers for use with your particular appliance. Tanks should only be stored in a locker installed and designed for LPG storage, outside the living areas of the boat.

Installation or added appliances should only be performed by qualified personnel.

Follow manufacturer's instructions for changing tanks.

Ensure good ventilation.

Avoid inhalation of vapor.

When handling cylinders, wear protective footwear and suitable gloves.

When handling cylinders (above head height) protective headgear may be necessary.

When changing tanks, wear suitable gloves and safety goggles or face shields.

Avoid contact with the eyes.

5.5.6 Exposure Controls / Personal Protection

- Skin Protection – Wear suitable protective overalls with long sleeves to cover exposed skin.
- Eye Protection – Use chemical goggles or face shield when changing tanks.
- Hand Protection – Use impervious gloves when changing tanks.
- Use suitable protective gloves when handling cylinders.
- Foot Protection – Wear safety boots or shoes when handling cylinders.
- Head Protection – When handling cylinders above head heights, protective headgear may be necessary.

5.5.8 Stability and Reactivity

Stable at ambient temperatures.

Hazardous polymerization reactions will not occur.

5.5.9 Material to Avoid

Avoid contact with strong oxidizing agents.

5.5.10 Hazardous Decomposition Products

Normally Carbon Dioxide. Incomplete combustion will generate Carbon Monoxide. See the Boating Safety Chapter for more information on Carbon Monoxide.

Note: Can form explosive mixture with air.

5.5.11 Toxicological Information

Eyes: Will present a risk of serious damage to the eyes if contact with liquid or vapor pressure jet occurs.

Skin: Will cause cold burns (frostbite) if skin contact with liquid occurs.

Fig. 5.8 Exposure Limits

	Long Term Exposure Limit (PPM) (8 hr TWA)	Short Term Exposure Limit (PPM) (10 min period)
Butane	600	750
LPG	1000	1250
Propane	None Established. Considered to be an asphyxiate at high concentration in air	

(source: India LPG)

Inhalation: Low vapor concentrations may cause nausea, dizziness, headaches, and drowsiness. High vapor concentrations may produce symptoms of oxygen deficiency which, coupled with central nervous system depression, may lead to rapid loss of consciousness.

ABUSE: Under normal conditions of use, the product is not hazardous. Abuse involving deliberate inhalation of very high concentrations of vapor, even for short periods, can produce unconsciousness and/or result in a sudden fatality.

5.5.12 Environmental Information

Spills are unlikely to penetrate the soil.

Unlikely to cause long term adverse effects to the environment. Will photo-degrade under atmospheric conditions.

Unlikely to cause long term effects in the aquatic environment.

5.5.13 Disposal Considerations

Product discharge may only be carried out by qualified persons.

- Do not dispose of any LPG container.
- Return all cylinders to the supplier.

Note: This section on LPG is to be considered as a Danger alert. However, we have added in the following additional precautions and warnings.



Open flame cooking appliances consume oxygen. This can cause asphyxiation or death.

Maintain open ventilation.

Liquid fuel may ignite, causing severe burns.

Use fuel appropriate for the type of stove installed.

Turn off stove before changing tank.

Do not use for comfort heating.

Use special care for flames near urethane foam.

Once ignited, it burns rapidly, producing extreme heat and releasing hazardous gasses and consuming large amounts of oxygen.

Specifically follow all warnings and instructions in your Owner's Manual, your Operator's Manual, and the equipment Manufacturer's Manuals provided to you.

5.6 Troubleshooting

Though we cannot cover every problem you might encounter in boating, we hope to assist you in the basic operation and maintenance of the components aboard, or installed on your boat.

As difficult as it would be to also cover every option or component installed we hope we have covered the basic essentials you will need in order to have many a safe and comfortable outings in your new boat. As in all cases always consult your OEM manuals in all cases of review of the documentation of the components aboard or installed on your boat. If the manuals are not available in your owner's packet, contact Hunter Marine, or your dealer. It is the ultimate in importance that you understand all you should about the equipment on your boat.

Here we give you a short guide concerning the troubleshooting of the equipment that fall in the underwater gear section of your boat. Read this guide, and use it in trying to discover the root of any issues that might arise.

Remember: OEM manuals take precedence over any information you may find in the Hunter Owner's or Operator's Manual Packet.

NOTE:

The following information is only a basic recommendations on the fuel systems's trouble shooting. Please refer to engine manufacturer's manual for for details on troubleshooting and maintenance.

Troubleshooting		
Problem	Cause	Solution
Fuel overflows at the fill plate (tank not full)	Fill or vent line blocked	Check lines. Clear obstruction from line or straighten line if kinked.
Water or moisture in fuel tank	Cap on deck fuel fill plate not tight	Check cap. Tighten.
	Condensation forming on walls of partially filled tank. Poor quality fuel from marina tanks.	Follow remedies for "Condensation" above. If remedies fail to correct problem, fuel tank and lines may need to be drained and flushed. See your dealer for service. Diesel engines. Check fuel/water separators. Drain if necessary. Check with your dealer.
Engine cranks but will not start (fuel system)	Lack of fuel.	Clean fuel filter, check fuel level. Check whether anti-siphon valve, if so equipped, is stuck shut. Improper starting procedure. Re-view starting procedures in engine manual.
	Clogged fuel filter.	Check and replace fuel filter. Check fuel pump, fuel pump filter, fuel filter, and fuel tank line for cracked flanges or restricted fittings.

50cc ENGINE FUEL SYSTEM

- A. GENERATOR FUEL CONTROL VALVE
- B. ENGINE FUEL CONTROL VALVE
- C. ENGINE FUEL RETURN LINE
- D. ENGINE FUEL LINE
- E. ENGINE FUEL FILTER

- F. FUEL TANK VENT THRU HULL FITTING
- G. FUEL TANK VENT HOSE
- H. PORT FORWARD FUEL TANK
- I. PORT AFT FUEL TANK
- J. ENGINE COMPARTMENT
- K. FUEL FILL FITTING (ON DECK)

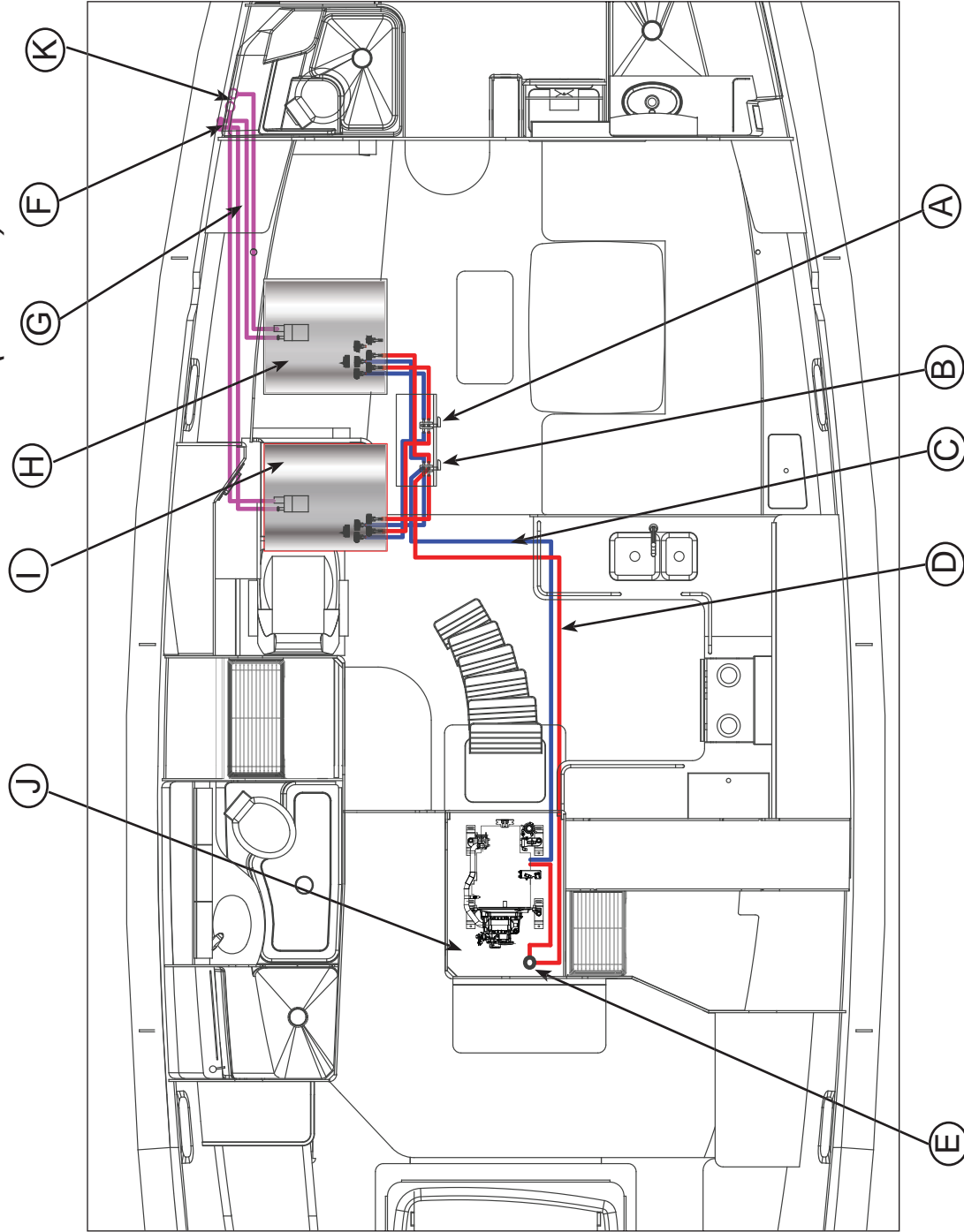

▲ DANGER ▲

California Proposition 65

Diesel Engine Exhaust and some of its components are known by the state of California to cause cancer, birth defects, and other reproductive harm.

Leaking fuel is a fire and explosion hazard. Avoid serious injury or death from fire or explosion.

NO SMOKING

Keep both sight gauge valves closed except when checking fuel level.

Do not mistake the water fill, waste pumpout, or even a rod holder for the Fuel Fill, ensure you are placing fuel in the correct deck fitting.

Before starting the engines, open the engine compartment and check for fuel smell.

*If you smell fuel, do not start the engine; get everyone off the boat and get trained help to find and fix the problem.

▲ CAUTION ▲

The "Fuel System" chapter 5, and "Boating Safety" chapter 4 both contain important fuel related information. Take the time to read all the fuel related information in your Operator's Manual, Owner's Manual, as well as the O.E.M. manuals.

50cc GENERATOR FUEL SYSTEM (OPTION)

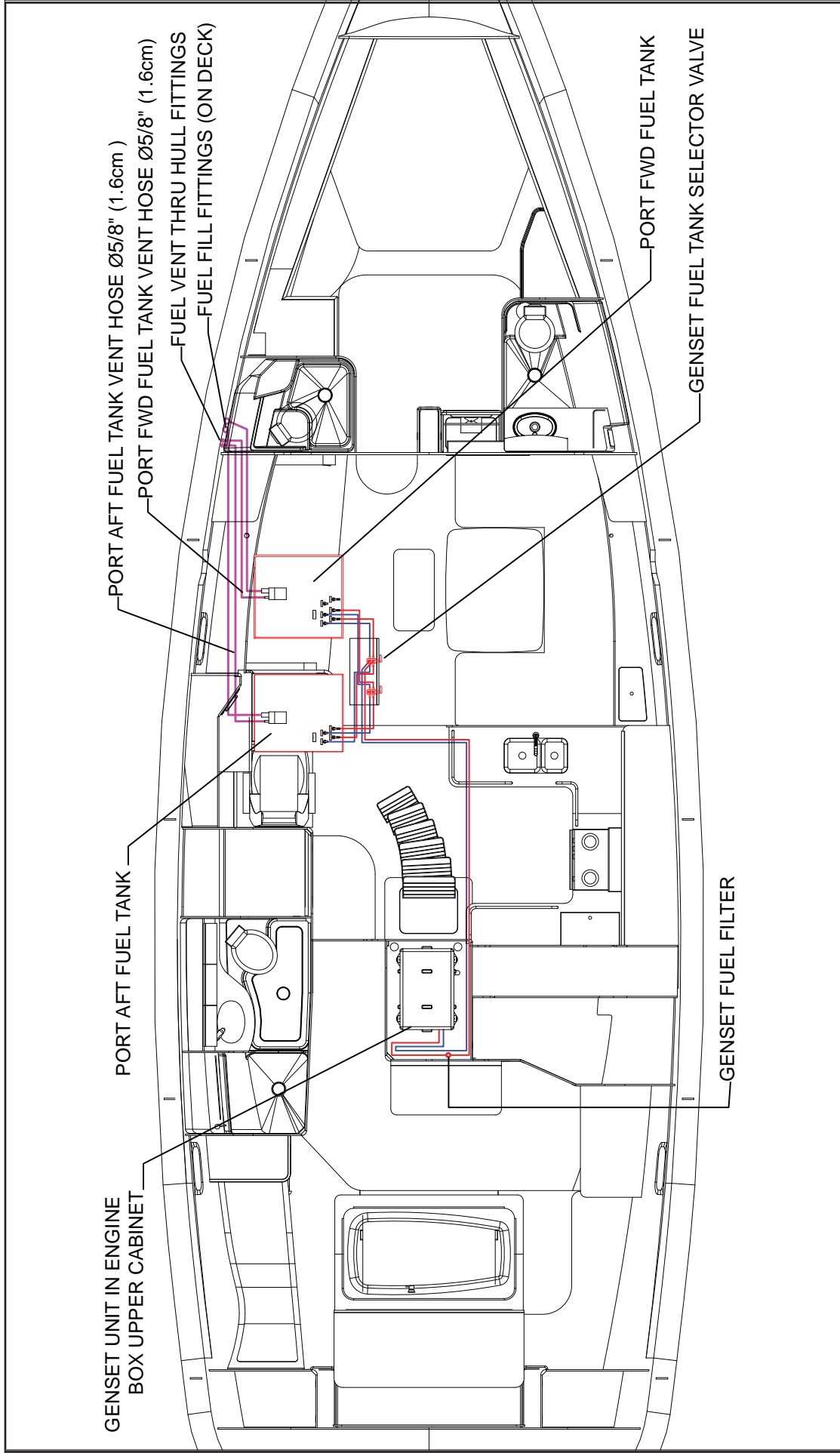



HUNTER®

MARINE CORPORATION

AN EMPLOYEE OWNERSHIP COMPANY

We Go The Distance

Chapter 6

***Underwater
Gear***

Hunter 50cc



Underwater Gear

Your underwater Gear consists of the following:

- Propulsion components (sail drive and bow thruster)
- Steering components
- Seawater Intake, and discharge skin fittings
- Monitoring Equipment
- Keel

6.1 Mechanical Propulsion Components



Keep clear of moving parts at all times. Protect moving parts from access during normal use.

Propulsion components are any component that would be involved in the movement of your boat.

6.1.1 Propellers

The propeller supplied with your boat has been selected as the best propeller for average use. Propellers use “pitch” or the angle of the blades to determine the amount of power exerted from your engines. Do not change the pitch of your propellers without getting your dealers recommendations first. If you change to a different propeller pitch, under no circumstances use a propeller which allows the engine to operate at a higher than recommended RPM. Your engine manual will specify the maximum recommended RPM.

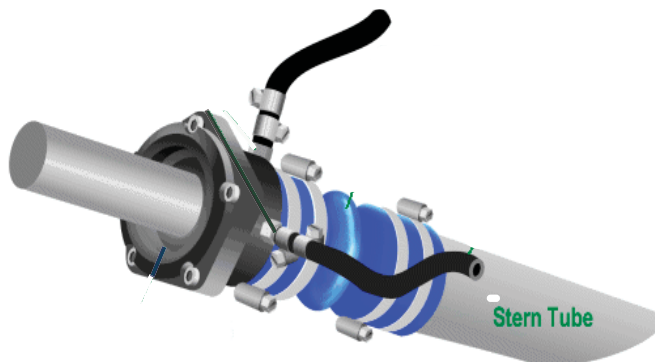

Fig. 6.1 shows the image of dripless stuffing box used on your boat

To maintain rated power, propellers should be free of nicks, excessive pitting and any distortions that alter them from their original design. Badly damaged propellers should be replaced, but those that are chipped, bent or merely out of shape can be reconditioned by your marine dealer.

6.1.2 Propeller Shaft

The propeller shaft is made of Aquamet 19 or equivalent stainless steel which has excellent corrosion resistance and very high strength. The coupling at one end of the shaft is bolted to the transmission. The other end of the shaft is tapered, threaded, and keyed for installation of the propeller. The propeller shaft passes through the hull encased in the shaft log.

6.1.3 Alignment

Aligning the engine with the propeller shaft is critical for smooth operation of your boat. Shaft alignment may change slightly after your boat is in use. Your dealer should check alignment as part of commissioning, particularly if there is vibration, a drumming sound, or loss of RPM's.

Below is an illustration showing the steps for alignment, however we recommend this practice be performed by competent professionals.

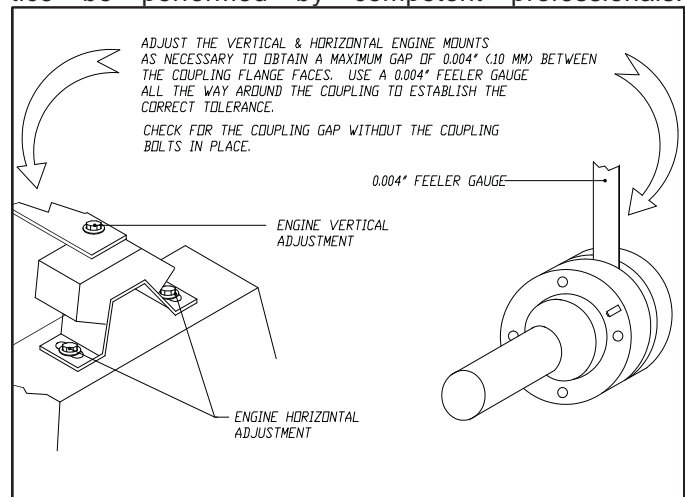

6.1.4 Struts

Each propeller shaft is supported by manganese bronze struts fastened to the bottom of the hull. The struts have replaceable bearings to minimize wear and to protect the shaft at the points where it passes through the strut

hubs. The strut bearings should be inspected annually and replaced as necessary. Location of the struts can be found in the Underwater Gear Components illustrations at the end of this chapter.

6.1.5 Shaft Log / Stuffing Box (Shaft Seal)

Your boat is equipped with drippless SureSeal as standard. The stuffing box keeps water from leaking around the shaft into the boat. The stuffing box has a Flex packing system. See fig. 6.1

Do your pre-departure routine check on the rubber tubing, hose clamps for cracking or loosen fasteners. Make sure to re-tightened all fasteners to avoid possible of leaking.

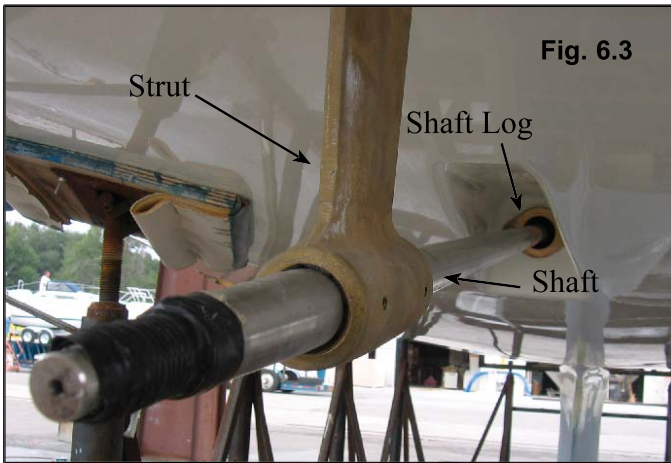

6.1.6 Alignment

Aligning the engine with the propeller shaft is critical for smooth operation of your boat. Shaft alignment may change slightly after your boat is in use. Your dealer should check alignment as part of commissioning, particularly if there is vibration, a drumming sound, or loss of RPM's.

If alignment is necessary, see your authorized service technician.

6.2 Steering Components



Keep clear of moving steering parts at all times. Protect moving parts from access during normal use!

6.2.1 Steering System

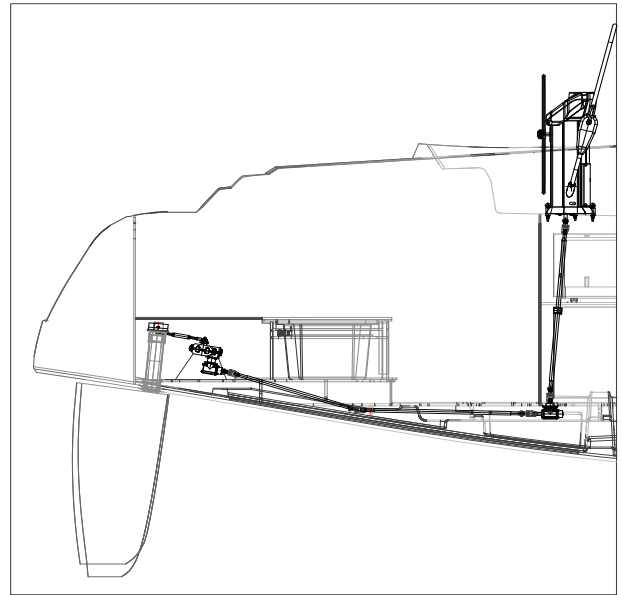

Fig. 6.4 the illustration shows basic steering mechanism and components of the boat

The steering system on your boat contains a steering wheel, shafts that connect the wheel to the steering gear via universal joints at each connection. Fig. 6.4 gives you a look at some of the basic components of this system.

The steering system also contains optional autopilot drive unit and rudder reference installed. The autopilot drive connects to the steering system via the output shaft of gearbox. IT'S STRONGLY RECOMMEND that a competent marine technician do the service or installation of the system.

WARNING: Keep clear of moving steering systems at all times. Protect moving parts from access during normal use

To keep the steering system in the top operating condition please **DO PRE-DEPARTURE ROUTINE CHECK UP ON THE STEERING SYSTEM OF YOUR BOAT.**

Note: If the steering system needs repair, your dealer has the correct tools. Do not try to service the system yourself.

6.2.2 Rudders

Your Hunter 50cc rudder is constructed with a foam filled composite blade by hand lay-up connected to an internal 316L stainless steel grid and rudder stock structure. The rudder bearings are self lubricating high tech needle type bearings with a double lip seal. Ensure to inspect the free and smooth operation of the rudder stock and bearings at regular intervals. This Figure gives you a look at the rudder under your boat. Your steering system is a very important part of your boat and very important to your boating safety. However, all boat operator's should be prepared for rudder failure or loss. That is why Hunter Marine has a backup rudder system that can be purchased for our current models. Other commercial suppliers offer similar systems at differing benefits and costs and you should conduct your own analysis to determine which alternative is best for you.



Fig. 6.5 shows image of rudder

Make sure the rudder swings easily & correct with wheel direction. Rudder and post inspected for cracks and/or concealed damage. Only a qualified Technician should repairs or doing the inspections for your need.



Because the backup system can also be lost an operator must be able to sail without a rudder or otherwise be prepared to assemble a makeshift rudder.

Important: Look to the Getting Underway Chapter (chapter 12) for information about using your emergency tiller system. The connections and use are detailed in that section.

The next Figure in this section will allow you to observe the cross section illustration of the rudder installed on your boat. This view also shows you the upper and lower rudder bearings.

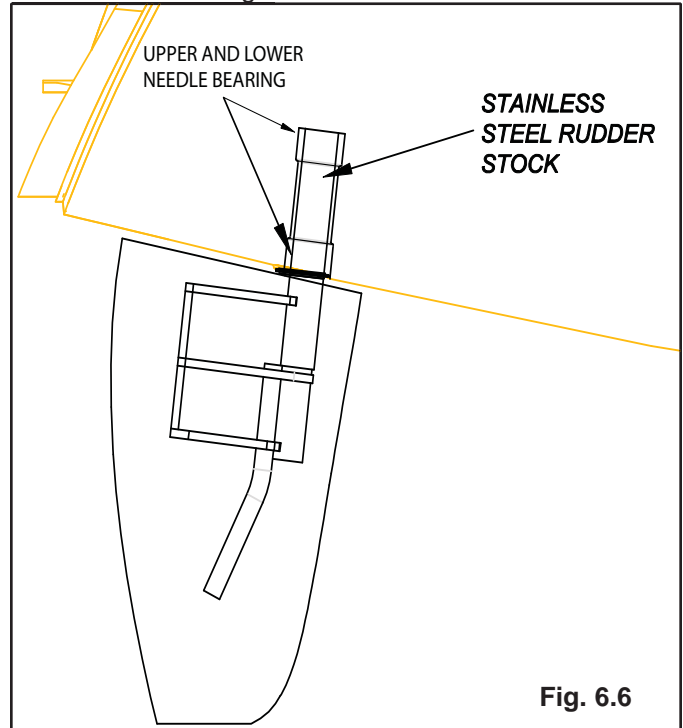

6.3 Seawater Intake

6.3.1 Pick Ups and Intakes

On the bottom of your boat, you will find pick ups and intakes for the supply of raw water to your boat's various systems.

The boat's operator should become familiar with the layout of the water and waste systems by walking through the boat with the diagrams provided in this manual. It is especially important that the operator knows all the thru-hull valve locations and inspects for leaks frequently.

Shown in the Fig. 6.7 is an example of three types of water intake fittings. These intake fittings are the "gravity fed" type, and the water forced type. The forced type is fed by the velocity of seawater being forced through the intake by the boat speed.

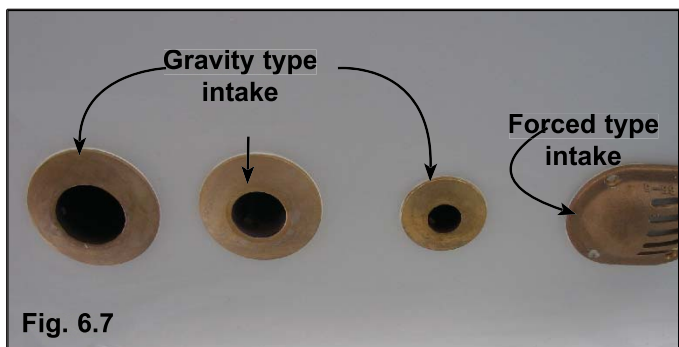

These types are always positioned with the opening side of the intake in the forward position. Gravity fed intakes are the opposite.

Care should be taken that these intakes and pick ups are cleaned of barnacles and other growth as specified in the maintenance section of this manual to maintain a clear, open passageway.

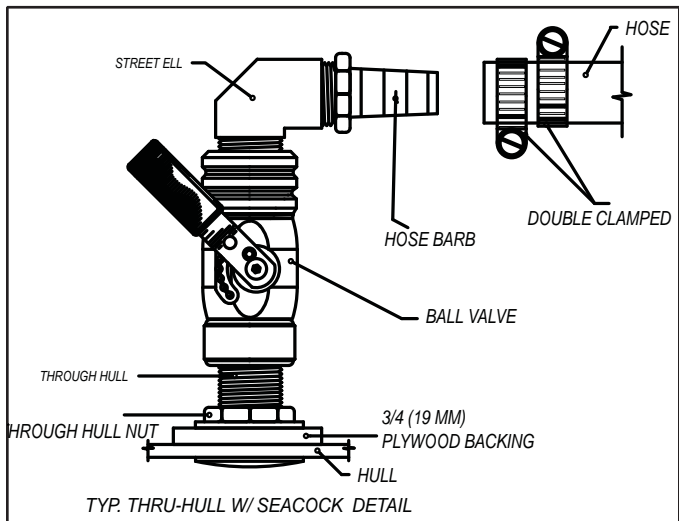

Fig. 6.8

The optional electronics package you have ordered on your boat will largely determine the underwater gear that is related to the monitoring equipment. Be sure and refer to your documentation in your owner's packet to find out the details about this equipment.

6.4 Windlass and Anchoring (Option)

6.4.1 Windlass

The windlass facilitates the anchoring of your boat by automatically raising and lowering the anchor. To operate the windlass, the windlass breaker at the battery switch panel must be switched on.

6.4.2 Windlass Operating

Please refer to the equipment's owner's manual for more details on the winlass specification and operating instruction.

Note:

It is important that the windlass clutch is tight for proper operation and safety. Periodically check the clutch and tighten if necessary.

Manual Chain Release - Turn off power at circuit breaker. Place handle in bi-square and undo the top nut approximately half of a turn. This will allow the chain gypsy to run free. The descent of the chain can be controlled and stopped by tightening the top nut with the winch handle.

Capstan Operation - Gypsy/Capstan models - To use the capstan independently, it is important to tie off or remove rope/chain from gypsy (engage gypsy pawl). The top nut can then be loosened allowing the capstan to be powered independently.

Emergency Manual Override - Where Fitted

Turn off power at circuit breaker. Place winch handle in bi-square and rotate clockwise. Remove winch handle after use.

Capstan Only Operation - Use Power up switch. Capstan units do not include manual chain release or emergency override.

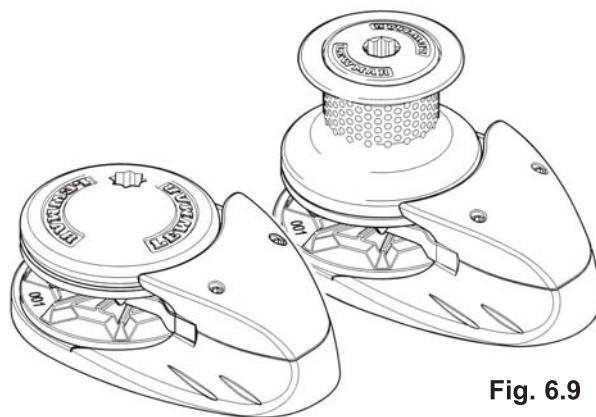

Fig. 6.9

⚠ DANGER ⚠

Make sure that the power is off before performing any maintenance or work on the windlass.

- Periodically check the motor and control box electrical connections, remove any residue and cover connections with a small coating of grease.

It is recommended that you, once a year, disassemble the windlass and remove residue buildup. To perform

Hunter 50cc• Underwater Gear

this maintenance follow all safety procedures and complete the following:

- Using the emergency handle, unscrew the nut by turning the handle counterclockwise.
- Remove the drum, upper cone, chain wheel, and lower cone.
- Wash down with water to remove any residue
- Coat surfaces with a light film of lubricant

- Reassemble the unit and tighten the clutch by turning the handle clockwise.

Note: Refer to your Owner's / Operator's Manual in your owner's kit for detailed information about your windlass.

6.4.2 Anchor

Your Hunter is equipped with a Danforth type anchor well and drain and a Danforth type anchor as standard equipment. The anchor is selected to suit the size and weight of your boat under normal anchoring conditions, and is most effective in muddy or sandy bottoms.

Fig. 6.10 will show you the details of the windlass and anchoring system in illustrated detail, showing the plan view.

Fig 6.11 shows you a profile view of the anchoring, and windlass system. This illustration shows the smaller and the larger anchor well, in relation to the location.

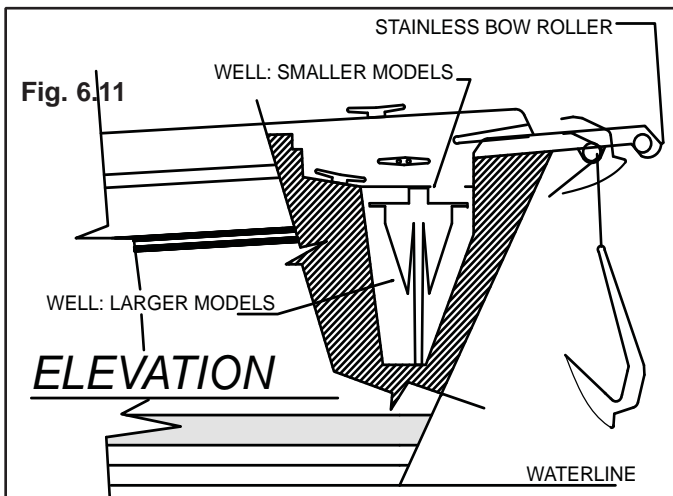

Anchoring in unusual water, and or weather conditions will require additional precautions. Consult an approved guide for suggestions.

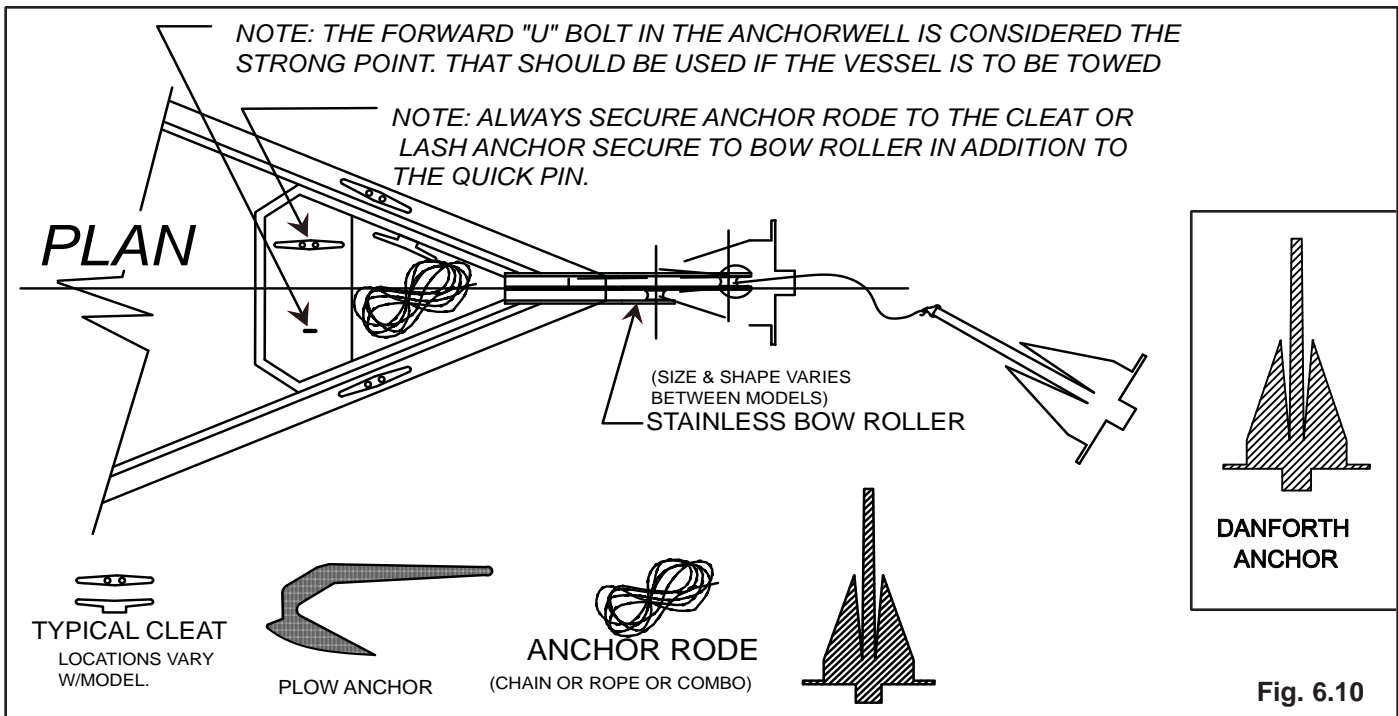

6.5 Bow Thruster (Option)

Your Hunter boat is offered with a bow thruster option. If installed the bow thruster will assist maneuvering in tight spaces or marinas and with adverse wind directions. The bow thruster is installed below your v-berth bunk into a tunnel that is built into the hull structure under the waterline. When operated it forces a jet of water from one side of the bow to the other and consequently pushes the bow towards the opposite direction of the jet. You should familiarize yourself with the maneuvering and operation of the bow thruster in open and still water before attempting to maneuver in tight spaces or marinas! The bow thruster is powered by your on board DC system and it is vital for this to be at full charge and capacity to assure full functionality. Please refer to the supplied vendor specific manual for safety tips and service requirements.



DANGER OF SERIOUS INJURY:

ROTATING PROPELLER – DO NOT SWIM IN THE VICINITY OF THE BOW THRUSTER!



Fig. 6.12 bow thruster tunnel



Fig. 6.13 The bow thruster control panel located on cockpit pedestal. See instructions on Bow Thruster user's manual for bow thruster operation. Refer to Bow thruster owner's manual for more details

6.6 Troubleshooting

Though we cannot cover every problem you might encounter in boating, we hope to assist you in the basic operation and maintenance of the components aboard, or installed on your boat.

As difficult as it would be to also cover every option or component installed we hope we have covered the basic essentials you will need in order to have many a safe and comfortable outings in your new boat. As in all cases always consult your OEM manuals in all cases of review of the documentation of the components aboard or installed on your boat. If the manuals are not available in your owner's packet, contact Hunter Marine, or your dealer. It is the ultimate in importance that you understand all you should about the equipment on your boat.

Here we give you a short guide concerning the troubleshooting of the equipment that fall in the underwater gear section of your boat. Read this guide, and use it in trying to discover the root of any issues that might arise.

Remember: OEM manuals take precedence over any information you may find in the Hunter Owner's or Operator's Manuals.

6.7 Emergency Tiller System

The tiller assembly is stored in transom upper locker. The location of the tiller assembly is very visible when you open the locker.

Emergency tiller system of your boat contains tiller base and tiller lever. The bottom end of tiller is fitted on the rudder quadrant and secured by a safety pin, the upper end

attaches to tiller level and secured by a safety pin which holds the tiller base and the lever together.

6.7.1 Before Using Emergency Tiller System

1. If the boat is equipped with autopilot, disengage the system.
2. Ensure the safety pin on rudder quadrant is secured in place.
3. Check on the rudder assembly, make sure the rudder will rotate freely.
4. If steering gear jams, rudder will not turn from its quadrant. The tie rod linked between gear box and rudder quadrant should be removed using appropriate tools. Rudder should rotate freely as soon as the lock nuts are loosened and removed.
5. If the boat is equipped with autopilot, you will need to disconnect rudder sensor from rudder quadrant, then the rudder quadrant should turn freely.

6.7.2 Use of Emergency Tiller System

1. Remove the stainless access plate which located in front of transom center seating on deck. Removing this access plate using designated wrench to open the plate.
2. Remove the tiller base access cover. this access cover is located on the center of aft cabin aft headliner.
3. Open aft cabin bunk aft lid. First, check on the possible loose connection of the gear, bolts that were mounted and secured on the rudder quadrant. Second, check on the rudder stock, make sure the safety pin is inserted in place.
5. Insert Tiller Base through access from outside through deck to rudder quadrant. Install tiller lever into handle base and have safety pin inserted.
6. Install the tiller assembly on rudder stock with the safety pin inserted in place.
7. Secure control line around tiller handle through hook eye on tiller handle then lead lines port & starboard through stern rail seats then on both aft winches. securing and tightening the control sheeting on both jib furling winches.

Note:

Use extremely caution when the boat is operating under using of emergency tiller.

6.8 Back-Up Rudder System (Option)



Because the Backup Rudder System may also be lost, Boat Operator MUST be able to sail without a rudder or otherwise be prepared to assemble a makeshift rudder.

6.8.1 SAFETY FIRST

1. **BE SURE TO SECURE YOURSELF AND ANYONE ASSISTING WITH RUDDER INSTALLATION WITH A SAFETY HARNESS, SAFETY LINE AND WEAR A PERSONAL FLOTATION DEVICE AT ALL TIMES.**
2. Drop sails, cut engine power and deploy anchor during installation to minimize stress on the backup system. Do not attempt this installation with the propeller shaft engaged.
3. Secure Rudder to prevent its loss. Always attach safety/recovery lines to the eyes located on the top and bottom of the rudder before attempting to install.
4. It is our recommendation that the Backup Rudder System be stowed in an easily accessible location such as an aft bulkhead.

6.8.2 Limitations on Backup Rudder System Use

1. Do NOT operate the boat over 4 knots with the Backup Rudder System in place.
2. The system is not designed to handle the rigors of racing or reaching full hull speed.
3. The Backup Rudder System is not designed or meant to be a replacement for your boat's originally equipped rudder. The Backup Rudder System should only be used to bring the boat to the closest port for a full repair.

50cc BILGE THRU HULL ARRANGEMENT

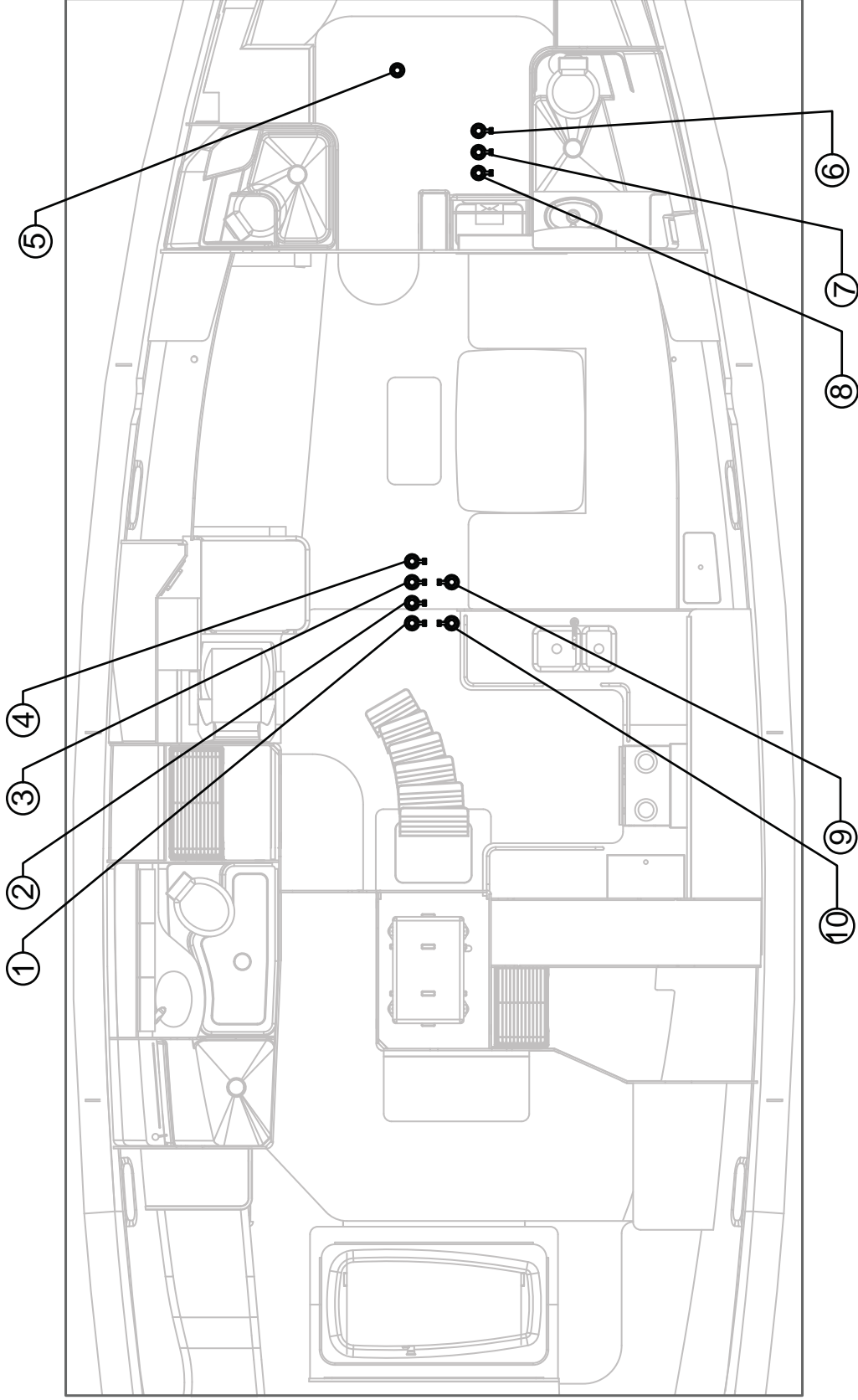

- 1. ENGINE PICK UP
- 2. GENERATOR PICK UP
- 3. MAIN CABIN MACERATOR DISCHARGE
- 4. OPTIONAL WASTE OVERBOARD DISCHARGE
- 5. MULTI FUNCTION TRANSDUCER

- 6. OPTIONAL FWD WASTE OVERBOARD DISCHARGE
- 7. FWD MACERATOR DISCHARGE
- 8. FORWARD VANITY DISCHARGE
- 9. OPTIONAL AIR COND PICK UP
- 10. COMBINED VANITY AND GALLEY DISCHARGE



50cc PORT SIDE SHEER THRU HULL ARRANGEMENT

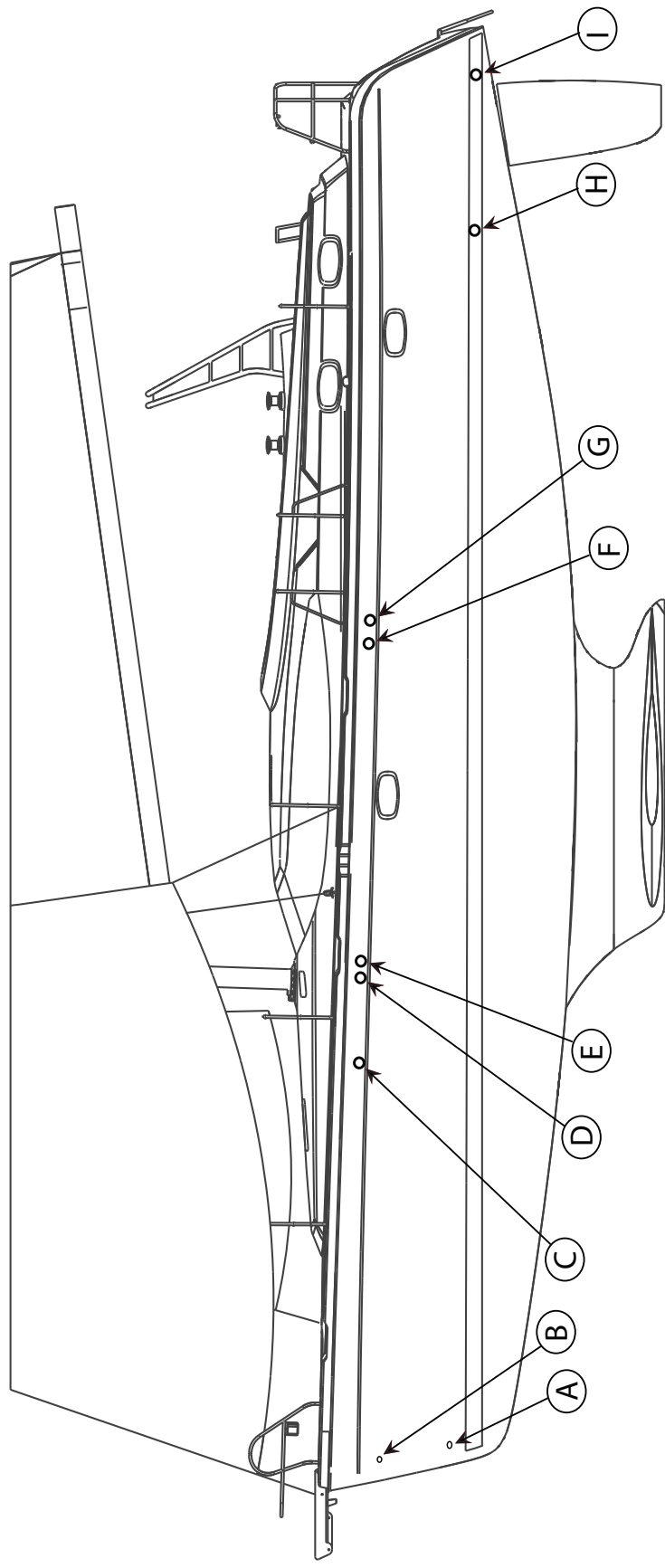

- A. ANCHORWELL LOW WATER DRAIN
- B. ANCHORWELL HIGH WATER DRAIN
- C. FORWARD WASTE TANK VENT
- D. FORWARD FUEL TANK VENT
- E. AFT FUEL TANK VENT
- F. ELECTRIC BILGE WATER DISCHARGE THRU HULL FITTING
- G. AFT WASTE TANK VENT
- H. AFT AIR CONDITIONING DISCHARGE THRU HULL FITTING
- I. ENGINE EXHAUST PORT



50cc STARBOARD SIDE SHEER THRU HULL ARRANGEMENT

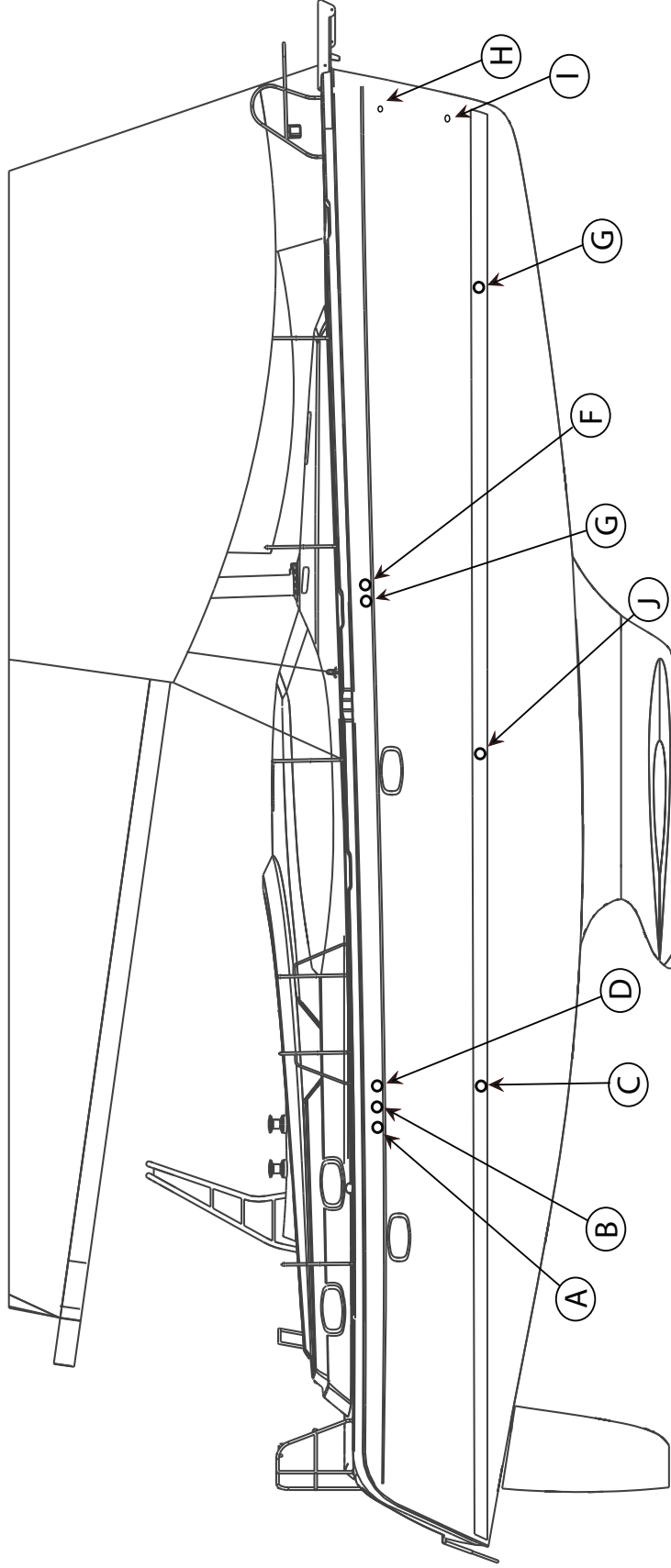

- | | |
|------------------------------------|---|
| A. STBD AFT WATER TANK VENT | F. FORWARD SUMP PUMP DISCHARGE THRU HULL FITTING |
| B. STBD FWD WATER TANK VENT | G. FORWARD AIR CONDITIONING UNIT DISCHARGE THRU HULL FITTING |
| C. GENERATOR EXHAUST PORT (OPTION) | H. ANCHORWELL HIGH WATER DRAIN |
| D. CENTER WATER TANK VENT | I. ANCHORWELL LOWER WATER DRAIN |
| E. N/A | J. MAIN CABIN AIR CONDITIONING UNIT DISCHARGE THRU HULL FITTING |





H U N T E R[®]

MARINE CORPORATION

AN EMPLOYEE OWNERSHIP COMPANY

We Go The Distance

Chapter 7

***DC Electrical
Systems***

Hunter 50cc



DC Electric Systems

This section will provide you with the information necessary to understand and operate your DC Electrical Systems.

It is not the scope of this manual to educate you on repair, or extending the electrical system. We cannot educate you in the principals of basic electricity. The scope of your manual is to provide you with the basic information you will need for safety, operation, and maintenance of these systems.

There are two main categories, the DC Electrical system and the AC Electrical systems. These are two entirely different systems though in lots of areas one dependant on the other.

From that point we will subdivide the main categories into sections beginning with the source of the power and continuing throughout the system to the component based in the systems circuitry. Remember within each main system are many sub-systems or circuits. These will be outlined as best as we can from beginning to end.

⚠ WARNING ⚠

Do not rely on the information in this manual as a repair guide, as always only competent electrical service personnel should attempt to repair any electrical equipment or extension of the electrical systems. To do so would risk electrical shock, or damage to the boats systems or components.

7.1 The DC Electrical System

The DC System consists of the following systems or components:

- Batteries
- Battery Switches
- Main Panel
- Lighting
- Pumps
- Distribution Panel
- Oil Changer (Option)
- Shower Sump
- Windlass
- Generator Starter
- Engine Starters
- Head Components
- Refrigerator / Freezer
- Fresh Water Pump
- Macerator
- CO Monitors
- Ventilation
- Entertainment Centers
- Fire Extinguishing System

Throughout this section, the components will be separated into categories of Power Supply and related components such as switches, breakers, fuses, panels, chargers, grounding and bonding, the components that are powered by the DC electrical system, and finally operations and suggestions for control or usage of the systems or components. At the end of the section, you will find a

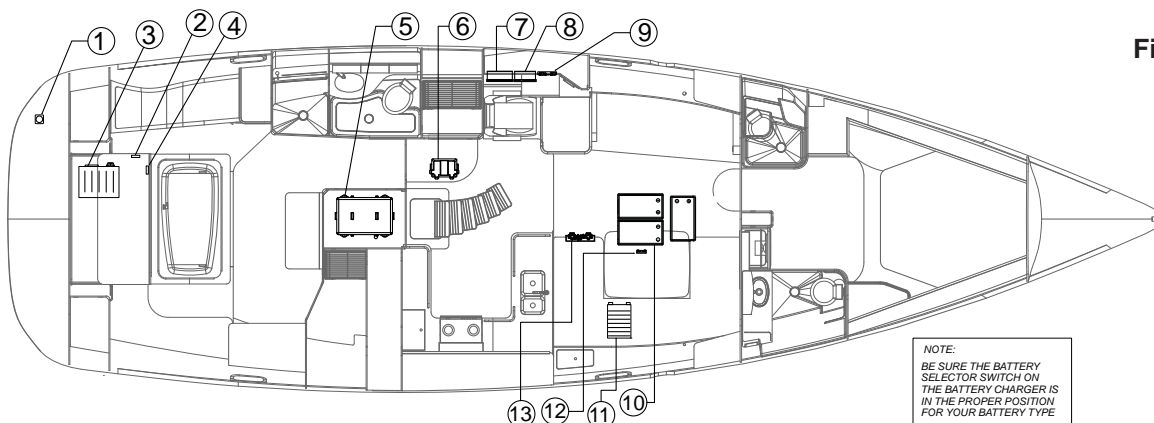

Fig. 7.1

- | | |
|---|--|
| 1. SHORE POWER | 8. DC DISTRIBUTION BOX (NAV STATION LOWER CABINET) |
| 2. SHORE POWER BREAKER (ON SIDE OF BUNK) | 9. AC/DC CONTROL PANEL (NAV STATION) |
| 3. ISOLATION TRANSFORMER (IN THE BUNK) | 10. HOUSE BATTERIES |
| 4. SECONDARY TRANSFORMER BREAKER (IN THE BUNK) | 11. OPTIONAL INVERTER |
| 5. OPTIONAL GENERATOR (LOCATES IN ENGINE BOX UPPER CABINET) | 12. HOUSE BATTERY BANK 300A FUSE |
| 6. ENGINE START BATTERY (IN BILGE COMPARTMENT) | 13. BATTERY SELECTOR SWITCH PANEL |
| 7. AC DISTRIBUTION BOX (NAV STATION LOWER CABINET) | |

“Legends” section that will detail the switch, breaker, and control panels aboard your boat.

7.1.1 Batteries



Batteries contain Sulfuric Acid and can cause severe personal injury if mishandled.
Avoid contact with eyes, skin, or clothing. In case of contact, flush with water at least 15 minutes.
If swallowed, drink large quantities of water or Milk of Magnesia, beaten egg, or vegetable oil and get medical attention immediately.



Charging batteries produces gasses which can explode if ignited.
Explosion can shatter a battery.
Battery acid can cause severe personal injury such as blindness.
Keep flame, spark, and smoking materials away from batteries while charging. Charge in a well ventilated area.

The DC System derives its power from two separate battery banks.

The negative terminal of all banks are attached to the DC Ground connection on the engine. This system, known as the negative ground system, is the approved system for marine DC electrical systems. The battery wiring system has two color coded wires. The yellow wire is the ground (negative), and the red wire is (positive).

To avoid explosions, do not use jumper cables and a booster battery to start the engine. If batteries are dead, then remove and recharge them ashore.

Batteries produce hydrogen and oxygen gasses when they are being charged. These explosive gasses escape through the vent/fill caps and may form an explosive atmosphere around the battery if ventilation is poor. This gas may remain around the battery for several hours after charging. Sparks or flame can ignite the gas and cause an explosion.



Batteries contain a large amount of potential electrical energy!
Extreme care must taken when working with batteries.

An improper connection to a battery can release enough energy to cause severe personal injury or fire.

The following precautions must be taken:

- The wiring to the batteries must have proper over current protection in the form of fuse or breakers.
- Use only battery chargers that have been listed by a testing agency, such as Underwriters Laboratories, Inc.
- Follow the wiring diagrams exactly.

To remove the battery:

1. Turn off all power drawing breakers and isolate battery.
2. Remove negative (-) cable first, then the positive (+).

When you install a battery, the battery connections must be made properly.

1. Attach the positive cable to the positive (+) terminal on the battery.
2. Attach the negative cable to the negative (-) terminal on the battery.

Note: Batteries should always be removed and installed by trained, qualified persons to avoid all damages.

7.1.2 Battery Switch

Each battery has a battery selector switch (Fig. 7.2) located in the bunk face forward of the chart table.

The selector switches are marked as to which battery they control. Turning the selector switch to the Off position turns power off to the respective circuits, likewise, the On position turns power on.

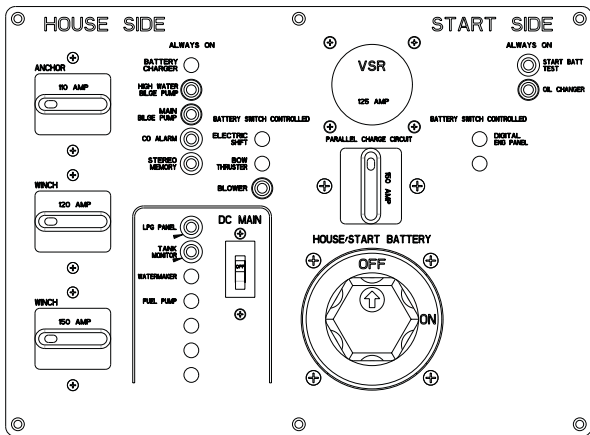

Fig.7.2

The battery switch panel houses the breakers for some of the main components in your DC system. The breaker controls are marked at the switch panel, and control systems or components on your boat that require a connection that remains energized even through the Main Panel may be de-energized.

The breakers and switches are described in greater detail in the “Breakers and Switches” section of this chapter.

7.1.3 Battery Charging System

Refer to the power supply locator drawing (Fig. 7.1) at the beginning of this section for the location of the battery charger. The charger is protected by a fuse on the positive and ground side at the charger.

To operate the charger, ensure that it is operating:

1. Connect the shore power cord to the shore power inlet on the stern of the boat on the stbd. side. Then to the dockside supply.
2. Turn on the AC Main breaker, located in the aft cabin.
3. Turn on the Battery Charger switch on the control panel.

7.1.5 Breakers, Switches, and Fuses

All electrical systems aboard your boat are provided with over-current protection in the form of breakers or fuses. Examples of breakers are the system or component controls at the Main Distribution Panel, or MDP, or in the battery selector switch panel. Systems that would normally

require you to energize them for use are provided with switches.

The breaker and switch panels are detailed further in the end of this section under “Legends.”

7.1.7 Generator (Option)

Although, technically, the generator is part of the AC System, because it supplies AC power, the starting of the generator requires DC power. The generator starting receives power from the start battery bank.

The generator supplies 120/240, volt 60 hz AC power for operating devices and equipment controlled through the AC control panel (Main Distribution Panel, MDP).

When the generator indicating light is on and the generator breakers are on, AC power is supplied to AC control panel devices and equipment.

Refer to the “Operation and Procedures” part of the AC Electric section for information on starting the generator.

You can find or locate the generator and all the respective components using the Generator System Drawing at the end of this chapter.

7.1.8 Main Control Panel (DC Side)

You can view the parts of the DC side of the main control panel here (Fig. 7.3). Notice the battery selector switch at the top left, when switched on the respective voltage of the battery is shown on the right by the digital volt meter. Indicator lights are built into most switches and alert you that the selected system is powered.

The distribution panel is outlined in the legends section of this chapter.

Refer to the “Operations” section of this chapter to view instructions on how to energize the separate systems on your boat.

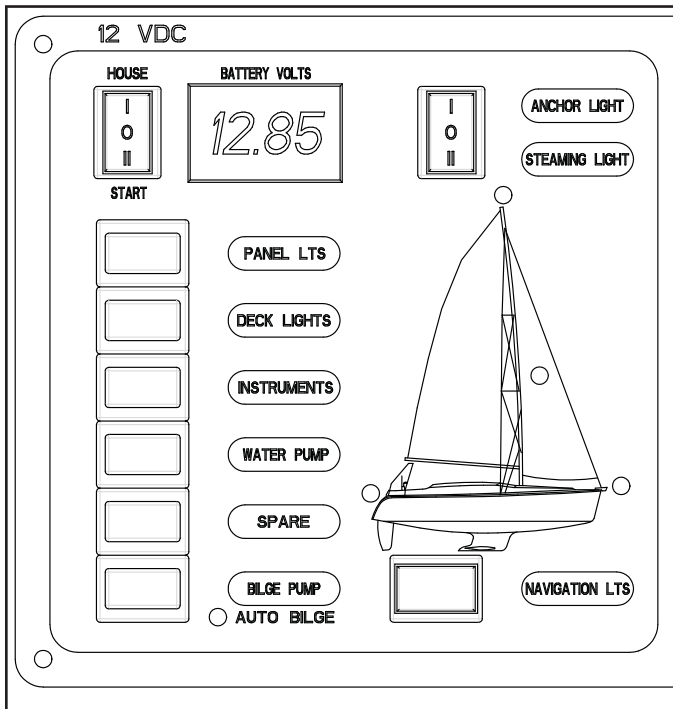

Fig.7.3

7.2 Systems and Components

There are many systems and components on the DC side of your boat from emergency and safety to entertainment. These systems make up the largest part of your electrical system.

Here we will discuss the electrical parts of those systems and try and give you a better understanding of the uses and features of your DC electrical systems and components. Since the largest part of your controls are at the MDP, we will start there and run down the systems and components as they are listed on the MDP. From there, we will look at the battery switch panel, and finally, the helm controls.

7.2.1 DC Main

In order to energize the DC system aboard your boat, you must turn the breaker marked “DC Main”, on the battery switch panel, to the “On” position. This supplies power to the remaining breakers and systems on the distribution panel.

7.2.2 Water Systems

The water systems are outlined in the Water Systems chapter in this manual. However, the controls and

monitors for these systems are all powered by the DC Electrical system.

The water tank monitor as shown in Fig. 7.4 allows you to select the tank to monitor the water level in the respective tank.



Fig.7.4

The power switch turns the monitor on, then select the tank you want to monitor. The gauge on the left will show the amount remaining in the tank.

The waste tanks are also monitored from this location by selecting numbers six, or seven from selector switch #1 on Fig. 7.4.

7.2.3 Refrigerator

The breaker marked “refrigerator”, on the main breaker panel behind navigation station access panel, supplies power to the DC powered refrigerator aboard your boat. See Fig. 7.5 for the arrangement layout of this system.

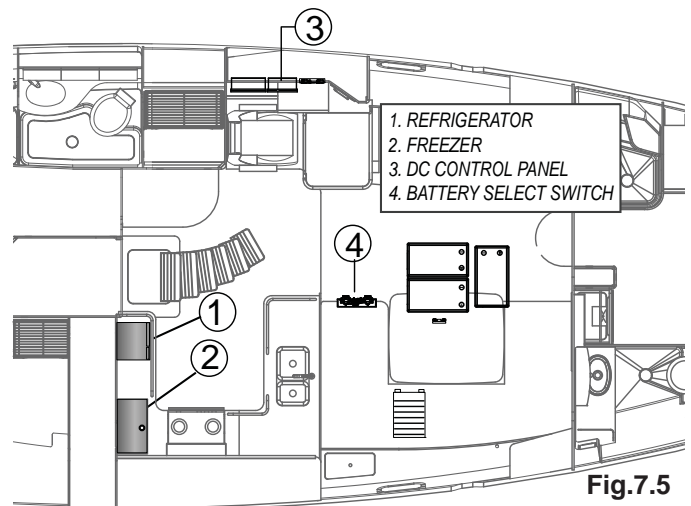

Fig.7.5

7.2.4 Lighting Systems

There are basically four different lighting systems aboard your boat. These are the interior and exterior lighting, the safety and navigational lighting, and, if supplied, the courtesy lighting.

The interior and exterior lighting systems are separated because of the method in which power is supplied to the two systems. The interior lights are powered from the MDP and marked Cabin Lights. The exterior lighting is powered from the MDP and have switches on the main control panel for their operation.

The engine room area lighting are also powered from the MDP.

The next area, safety and navigational lighting, closely follows Coast Guard regulations regarding safety and navigational lights. They are as follows:

- Nav Lights
- Steaming Light
- Mast Light
- Deck Light

The red and green lights on the bow rail and the white facing light on the transom are known as “Nav Lights”. These lights should always be on when motoring.

The “steaming” light is the forward facing light mounted halfway up the mast. This should be on when underway with sail power only.

The anchor light is a 360° light mounted at the top of the mast and should only be on when anchored.

The engine area lighting is controlled by the courtesy light breaker, and the Deck light gives lighting to the foredeck area.

Lighting circuits and locations are outlined in the end of this chapter.

7.2.5 CO Monitors

In each area aboard your boat, you will find a CO Monitor (Carbon Monoxide Monitor). We care about your safety and have installed these CO Monitors to show our concern. For more information about the CO Monitors mounted on your boat, consult your owner’s packet and

find the documentation for the CO Monitors.

7.2.6 Entertainment Centers

The entertainment centers in the berthing areas of your boat are 12 volt DC powered. The power is supplied through the distribution panel. The television is AC powered from a DC to AC inverter, and the stereo is DC powered. More information about the controls of your entertainment centers and equipment can be found in your owner’s packet.

7.2.7 Oil Changer (Option)

Your boat may be equipped with the optional oil changer. The oil changer receives its power from the DC Electrical System. The breaker is located on the Battery Switch Panel. The breaker is marked “OIL CHANGER.”

Consult your mechanical arrangement for the location of the oil changer.



Fig.7.6

Note: Discharge of oil is prohibited. The Federal Water Pollution Control Act prohibits the discharge of oil or oily waste into or upon navigable waters and contiguous zone of the United States. If such discharge causes a film or sheen upon, or discoloration of the surface of the water, or causes a sludge or emulsion beneath the surface of the water, violators are subject to a penalty of \$5,000.

7.2.10 Bilge Pump Systems

Your boat is equipped with 2 bilge pumps and one emergency bilge pump. For locations of the bilge pump systems, consult your Mechanical Arrangement Drawing or the Sanitary Systems Drawing.

The Bilge Pump System consists of a pump and a float

switch. When the water level rises far enough to activate the float switch, this activates the pump which lowers the water level down to a point that the float switch stops the power. Fig. 7.10 shows you the typical wiring.

For more information about your bilge pump system, see Sanitary Systems.

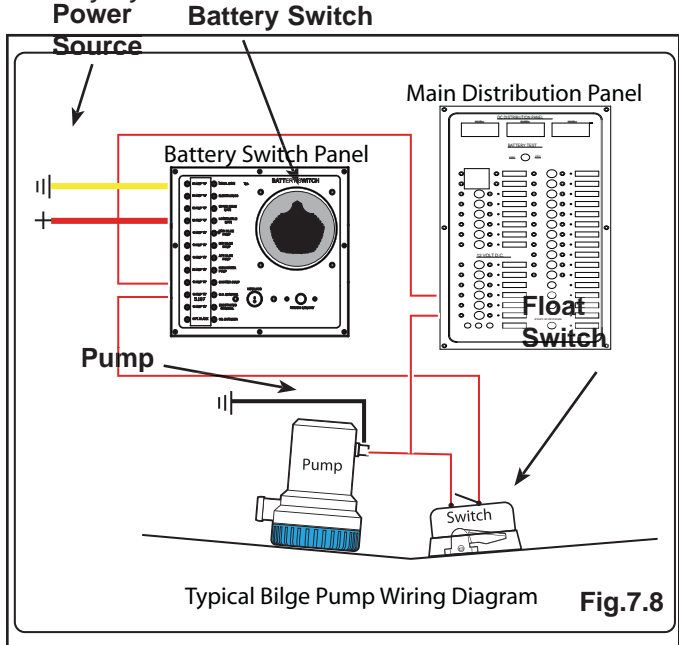

Typical Bilge Pump Wiring Diagram Fig.7.8

7.2.11 Ventilation

Ventilation is a very important issue with your boat, with the potential for Carbon Monoxide buildup (See Boating Safety Section), along with the simple comfort of fresh air or air conditioning, ventilation is a standard that is a necessity.

On your boat, there are essentially three types of ventilation, the air conditioning system (AC system), the blower, and the Bomar hatches, which supply you with fresh air when opened. Since the air conditioning system is AC powered (see AC Electric Section) and the hatches require no power, we will detail the blower (or fans), and their function, here.

For blower location, consult your Mechanical Arrangement illustration in the Boating Safety Section, or the Ventilation illustration in the same section.



Fuel fumes in the engine compartment can explode.

Before working on electrical wiring, ventilate engine room and disconnect battery cables to prevent sparks.

The engine room blower is an exhaust fan which will remove any exhaust fumes from the engine room, as well as, removing heated air.

7.2.12 Fire Extinguishing Systems

In the engine room, there is a fire extinguishing bottle installed. This system is DC powered with the relay, or “module”, and the alarm at the helm station.

When a fire is detected on your boat, the alarm will sound and set off the Halon bottle. This relay will shut down the engines, the blowers, and the generator. To reset the system, activate the reset switch on the monitor at the helm. See Fig. 7.9.

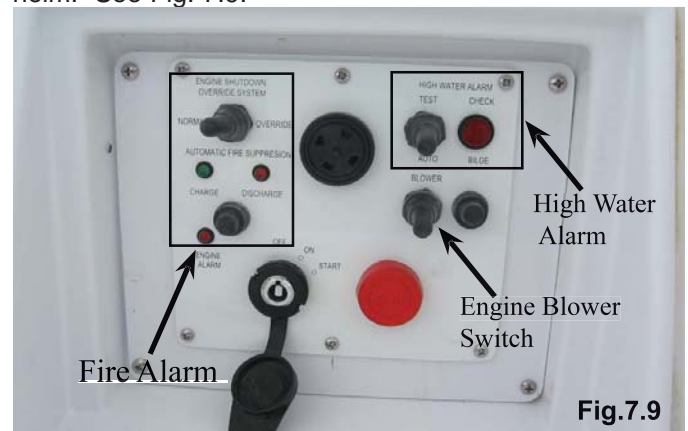

Fig.7.9

7.2.13 Shower Sump

The shower sump is part of the Sanitary System and more information about the Shower Sump can be found in that section. However, the breaker control for the Shower Sump can be found on the MDP.

7.2.14 Windlass

Your boat may be equipped with an optional windlass. It receives its power from the DC electrical system. The windlass offers you the ability to raise and lower your anchor. There is also a circuit breaker at the battery switch. The windlass can be operated from the bow. See manufacturer’s owner’s manual about the proper and safe operating procedures. See Fig. 7.12.

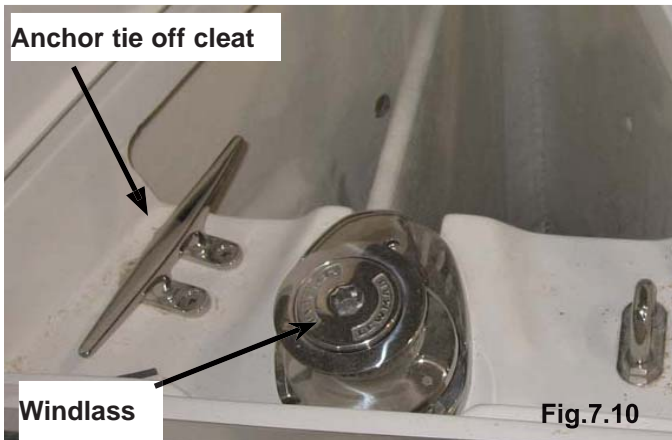

Important: U.S.Coast Guard regulations require that boats have a sanitation system on board to control pollution. Waste is to be stored in a holding tank or other device so it can be properly disposed of at a shore facility. Discharging this waste overboard in the U.S. lakes, rivers, bays, and sounds and within 3 miles of shore in international waters is prohibited. Check with the Coast Guard regarding regulations in your area.

1. Power up the DC panel as described in this section.
2. Open the seacock valve located under the steps to salon.
3. Switch the MACERATOR breaker at the DC main electrical control panel to ON.
4. Turn the macerator switch to the “on” position at the Nav Station. This is a momentary switch, you must hold the switch to operate.
5. Allow the macerator to run until the holding tank is empty, but no longer. Running the macerator when the tank is empty will damage the pump. When full, the macerator will have a low pitch grind. When empty, this changes to a high pitch grind.
6. When you hear the pump speed up (indicates tank is empty), immediately switch the MACERATOR breaker to OFF.
7. Close the seacock.

7.3 Operations and Maintenance

7.3.1 To operate the 12 Volt DC System:

1. Switch the main battery switch in the main salon bunk
2. Switch the DC main circuit breaker at battery switch panel to ON.
3. Switch on relevant breakers at the MDP.

Note: Always switch circuit breakers off when you leave your boat unattended.

7.3.2 To manually operate your bilge pumps:

Note: The power to the MDP does not need to be energized in order to manually operate your bilge pumps.

1. Locate the bilge pump switches at the Nav station and switch them to the manual position.
2. Another procedure to be used in extreme circumstances involves locating the float switch and manually rotating the float handle on the side of the float switch to simulate the float switch being underwater. This will energize the pump and the pump will operate.

7.3.3 To operate the macerator pump:



Do not place facial tissue, paper towels, or sanitary napkins in head. Such materials can damage waste disposal systems and the environment.



If the seacock is not closed, the holding tank will fill with sea water and could possibly flood the boat.

7.3.4 To operate the engine compartment blower:

Power up the DC system as discussed in this section. Turn on the rocker switch located in the aft cabin.

7.3.5 To operate the windlass:

1. Power up the windlass from the battery switch.
2. The controls for the windlass are on the deck to the right of the anchor well.

For more information about your windlass, refer to the Underway Section of this manual.

7.3.6 CO Monitors

For your protection, we have installed CO monitors aboard your boat. Be sure and check your Owner's Packet for more info concerning your CO detectors. You can also review that dangers of CO in the Boating Safety Chapter of this manual.

Do not spray waxes or cleaning agents on the monitor.

7.3.7 Maintenance

The maintenance of your DC system is ensuring that all connections are clean, tight, and covered with a corrosion inhibitor compound.

Hunter 50cc • DC Electric

Troubleshooting		
Problem	Cause	Solution
12 volt equipment not working	Battery selector switch turned off	Check battery selector switches and ensure they are on
Battery not charging with engine running	Check alternator, belt, etc.	Change alternator, tighten belt
Battery not holding a charge	Faulty Battery Faulty battery charger	Replace battery Have your dealer check battery charger
12 volt DC device not working	Circuit breaker for device is off Weak or dead battery Faulty electrical connection	Switch breaker to on Change battery selector switch position, recharge battery Check 12 volt DC connections, tighten or repair as needed
Cabin lights not working (off or dim)	Cabin breaker for device is off Weak or dead battery Light bulb burned out	Switch breaker to on Change battery selector switch position, recharge battery Replace bulb
Blower inoperative	Tripped breaker Weak or dead battery	Switch breaker on Recharge or replace battery

Basic Power Supply System Layout

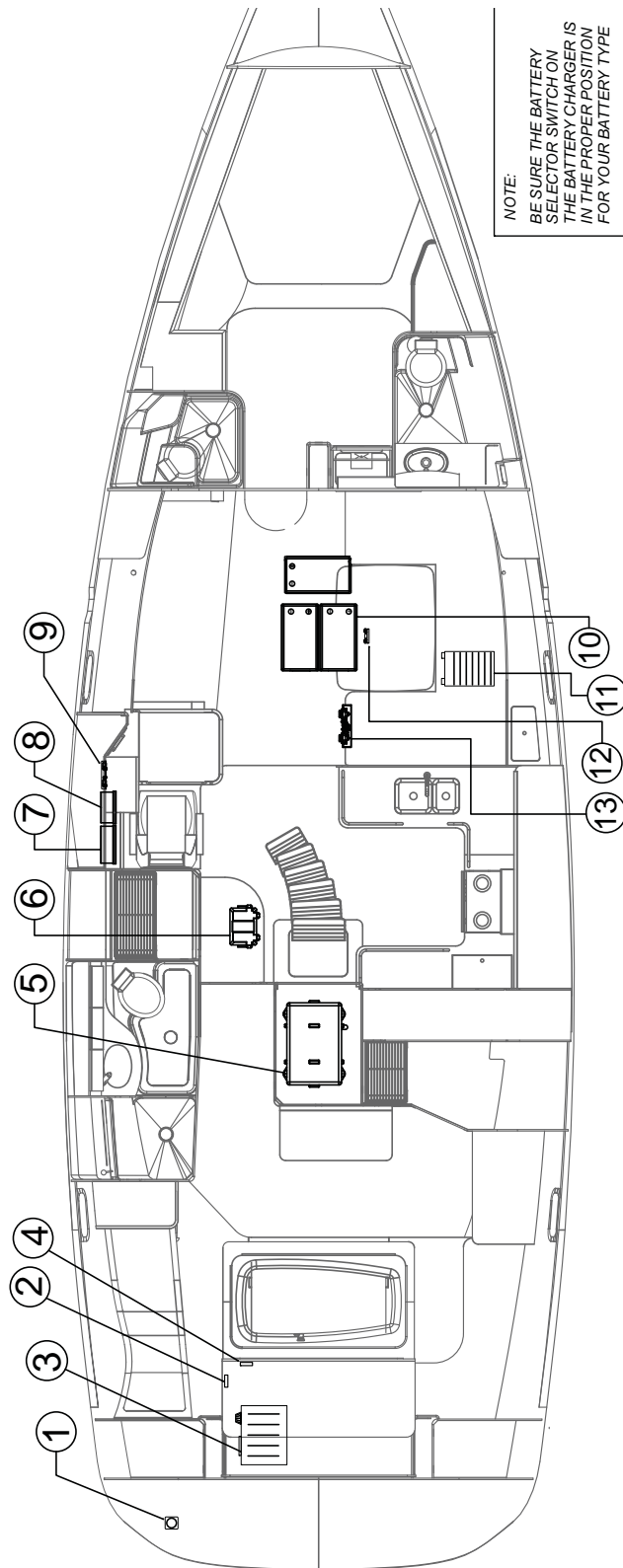

NOTE:
BE SURE THE BATTERY
SELECTOR SWITCH ON
THE BATTERY CHARGER IS
IN THE PROPER POSITION
FOR YOUR BATTERY TYPE

- | | |
|---|---|
| <ul style="list-style-type: none"> 1. SHORE POWER 2. SHORE POWER BREAKER (ON SIDE OF BUNK) 3. ISOLATION TRANSFORMER (IN THE BUNK) 4. SECONDARY TRANSFORMER BREAKER (IN THE BUNK) 5. OPTIONAL GENERATOR (LOCATES IN ENGINE BOX UPPER CABINET) 6. ENGINE START BATTERY (IN BILGE COMPARTMENT) 7. AC DISTRIBUTION BOX (NAV STATION LOWER CABINET) | <ul style="list-style-type: none"> 8. DC DISTRIBUTION BOX (NAV STATION LOWER CABINET) 9. AC/DC CONTROL PANEL (NAV STATION) 10. HOUSE BATTERIES 11. OPTIONAL INVERTER 12. HOUSE BATTERY BANK 300A FUSE 13. BATTERY SELECTOR SWITCH PANEL |
|---|---|

⚠ DANGER ⚠

Fuel Fumes in the engine compartment can explode! Before working on any electrical wiring, ventilate the engine compartment and disconnect the batteries to prevent sparking.

Never use an open flame in a battery storage area.

Batteries can explode if a spark or flame ignites the free hydrogen given off during charging.

Batteries contain Sulfuric Acid and can cause severe personal injury if mishandled. Avoid contact, flush with water for at least 15 in. If swallowed, drink large quantities of milk of magnesia, beaten egg, or vegetable oil, and get medical attention immediately.

Never reset a breaker that has tripped without first correcting the problem. Electrical system devices can be damaged and be faulty which can cause fire. Always correct the problem causing the tripped breaker before re-energizing.

Alterations or extensions to your electrical system can cause electrical fire or shock.

NOTE: BE SURE THE BATTERY SELECTOR SWITCH ON THE BATTERY CHARGER IS IN THE PROPER POSITION FOR YOUR BATTERY TYPE.

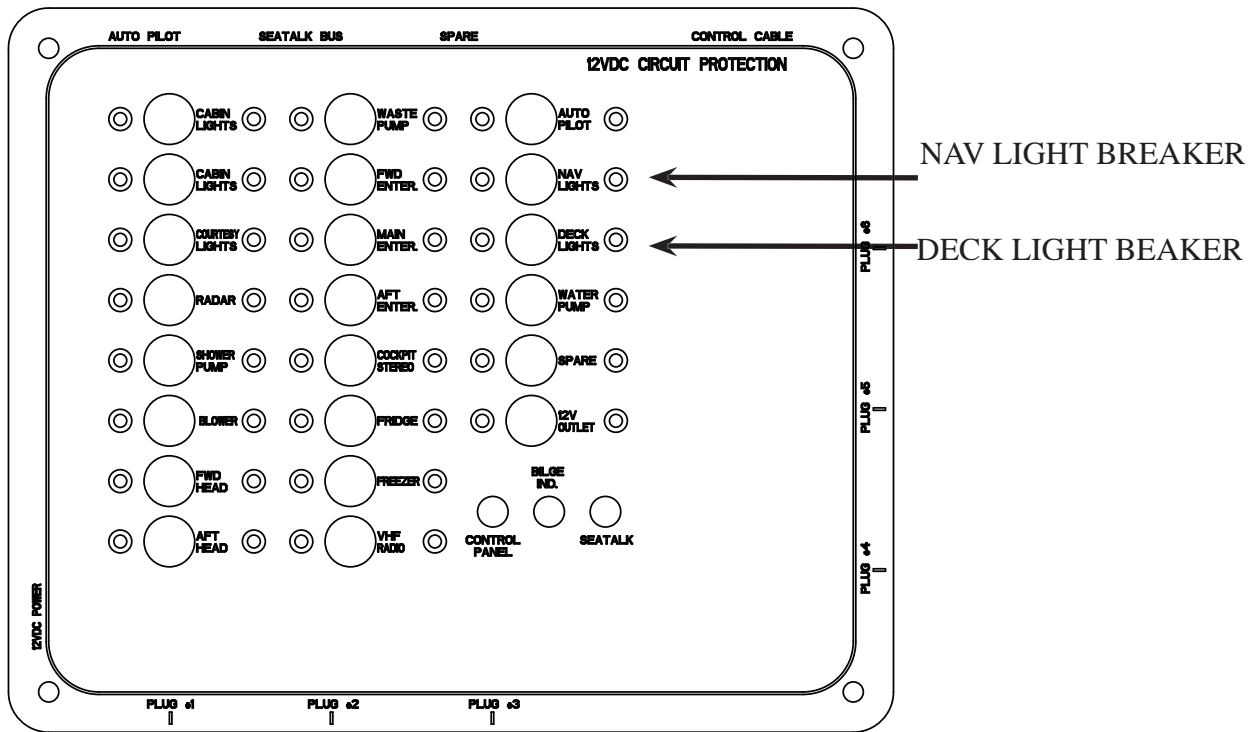
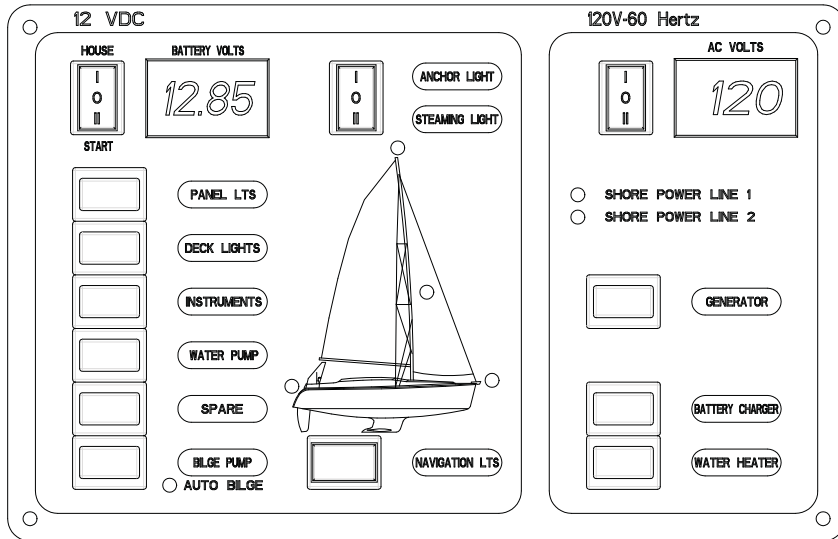



H U N T E R[®]

MARINE CORPORATION

AN EMPLOYEE OWNERSHIP COMPANY

We Go The Distance

Chapter 8

AC Electric Systems

Hunter 50cc



The AC System consists of the following systems or components:

- Shore Power Connection
- Shore Power Breaker
- Isolation Transformer
- Generator (Optional)
- MDP
- Breakers
- Components

Important: The AC system is connected to the living quarters of your boat through an AC junction panel located on the Port side behind the cabinets in the Salon area. See the AC Mechanical Arrangement for further location details.

! WARNING !

Electricity cannot be detected without the use of specialized test equipment. Never think you know whether a circuit is “live”. Always have qualified, competent professionals inspect or make repairs to your electrical systems.

Throughout this section, the components will be separated into categories of Power Supply and related components such as switches, breakers, fuses, panels, chargers, grounding and bonding, the components that are powered by the AC electrical system, and finally, operations and suggestions for control or usage of the systems or components. At the end of the section, you will find a “Legends” section that will detail the switch, breaker, and control panels aboard your boat.

The sources for power supply in your AC electric system are the shore power, the generator, and AC electric supplied through the inverter. We will explain both systems as if your boat came to you with a generator installed. If you opted not to have the generator, then simply omit the sections that deal with that part of the boat. They will not apply to your boat.

Note: It is important that you review the “Electric Shock” pamphlet included with your manual and understand the importance of electrical safety. While electricity is one of our greatest friends, it can well be your worst enemy. Be sure and follow the warnings posted in this manual and your component or systems manuals in your owner’s packet and practice good safety. Always have trained, competent technicians to service your electrical systems, it could mean your life.

8.1 Power Supply Components

As we mentioned, the two main sources for AC power are the shore power and the generator. There is a breaker switch on the control panel that allows you to switch between the two power sources without energizing both at once.

The branch breakers are in the MDP located port main salon behind aft seatback.

! DANGER !

Never work on an energized circuit! Always treat any circuit as if it were live! Always have trained, competent technicians to service your electrical systems!

8.1.1 Shore Power Supply

Your boat has a shore power inlet a 50 amp 120/240 volt (230 overseas) line supplies power to the AC MDP.

! WARNING !

Using a damaged or improper cord for shore power can cause electrical shock and serious injury. Use a cord specifically designed for shore power connection. Do not use a household extension cord.

! CAUTION !

Water is an excellent conductor of electricity. Keep shore power cord out of water. Do not operate any AC device while you or the cord are in the water. To prevent injury or equipment damage, keep all AC system components dry.

! WARNING !

DO NOT connect the shore power cord to the dock-side electrical source first. You could accidentally drop the cord into the water, which may result in electrical shock and serious personal injury.

! CAUTION !

Be certain the water heater is full of water and does not contain air. If the water heater is not full of water, damage to the heating elements may result when the electrical power is turned on to the unit.

Fig. 8.1 gives you a look at the shore power connection on the transom of your boat.



Fig. 8.1
Shown is the aft shore power connection.

Later on in this section, we will detail the steps to connecting your shore power. Lets take a look at more of the shore power components.

8.1.2 Shore Power Cord

We have supplied you with a durable 50' shore power cord. The cord will have a male connection on one end and a female connection on the other end. Do not use chemicals to clean or service your shore power cord, unless specified by the manufacturer. Follow the manufacturer's recommendations on servicing or cleaning your shore power cord.

8.1.3 Isolation Transformer

Beyond the shore power connection and the shore power breaker, your AC power will be routed through the Isolation Transformer. See the Mechanical Arrangement Illustration for the location of the ISO Transformer.

The ISO Transformer is a standard "dry" type 12 KVA transformer that basically isolates your boat from the shore power. It is a valuable safety feature aboard your boat.

8.1.4 Distribution Panel (MDP)

Here is a look at the distribution panel installed on your boat. The distribution panels for both AC and DC power are located behind the nav station seat.



Fig. 8.2 Generator (Option)

The generator is a diesel powered engine, so there are some safety rules for any type of fuel engine. Lets look at some instructions of the wired remote control panel and you can find more details on the generator's instruction manual.

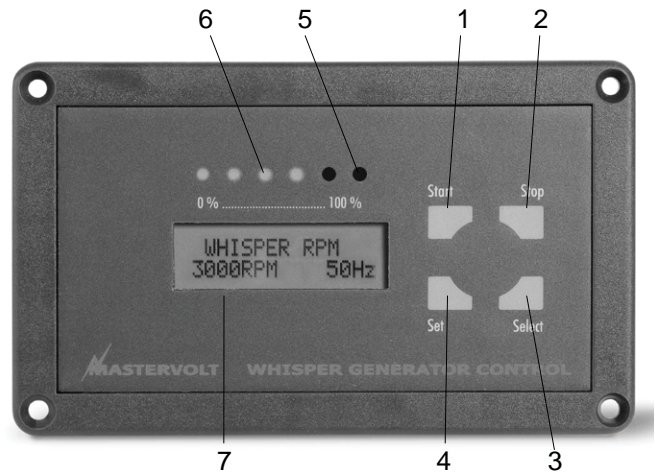

Generator Control Panel

- 1 Start button;
- 2 Stop button;
- 3 Select button;
- 4 Set button;
- 5 Failure lamp;
- 6 Generator load indicator.
- 7 Display

! DANGER !

Fuel leaking from any part of the fuel system can lead to fire and explosion that can cause serious bodily injury or death. Inspect system before starting engines.

! DANGER !

Never enter the engine compartment without proper ventilation first. A spark caused by power tools or lighting equipment could result in fire or explosion which could cause personal injury or death.

! DANGER !

As with any fuel burning engine, Carbon Monoxide is a concern. Read the Boating Safety section of this manual, and educate yourself about Carbon Monoxide poisoning. It could mean the difference in your life and the life of your loved ones.

For the more details on operating instructions, maintenance instructions of the generator, please refers to the generator owner's manual.

8.1.7 Breakers, Switches, and Fuses

All electrical systems aboard your boat are provided with over-current protection in the form of breakers or fuses. Examples of breakers are the system or component controls at the Main Distribution Panel, or MDP Systems that would normally require you to energize them for use and are provided with switches.

The breaker and switch panels are detailed further in the end of this section under "Legends."

8.1.9 Outlets and GFI Components

The outlets aboard your boat are for AC electrical connections to supply power to your AC accessories. They are just like your outlets in your home and supply 110 volt (230 volt overseas) AC power.

There are 2 required GFI outlets aboard your boat. One is in the galley, one at the Nav station. Though there are several other outlets, they are wired in the circuit of an

existing GFI. The other outlet such as the one that supplies power to your microwave receives power from the MDP and breaker protected at that point. These are usually placed behind cabinets or the components that they supply power to and aren't visible.

Though the outlets are a system or a component such as in the next subject, we have placed the descriptions in the Power Supply subject due to the purpose of their installation.

As with the DC System, there are several AC powered systems or components aboard your boat. Here we will break those down for you with a function and description of each one. Later in the Operations and Maintenance section, we will describe the use or operation of these systems or components.

8.2 Systems and Components.

8.2.1 Inverter (option)

The inverter locates in main cabin starboard bunk. Typically, there are two modes of operation associated with an inverter/charger:

Inverter Mode:

Direct current (DC) from the boat's batteries is transformed into alternating current (AC) for use with you household electrical appliances.

Charger Mode:

Alternating current (AC) is taken directly from shore power (or other AC sources) and passed directly to your household appliances. At the same time, the incoming AC is also converted to DC to recharge the boat's batteries.



Fig 8.3

8.2.2 Water Heater



Be certain the water heater is full of water and does not contain air. If the water heater is not full of water, damage to the heating elements may result when electrical power is turned on to the unit.

The water heater use and function is described in the Water Systems Section. Here we will detail the electrical side of the heater.

The water heater is powered by the MDP on the Navigation Station. It is much the same as an electric water heater in your home, Consult the manufacturer's documentation for any internal information about the water heater.

When the Water Heater is operating from the Heat Exchanger, water temperature in the tank will approach the temperature of the engine coolant.

The Temperature Control Valve (TCV) regulates the flow of coolant through the Heat Exchanger by sensing the output temperature of the water in the tank

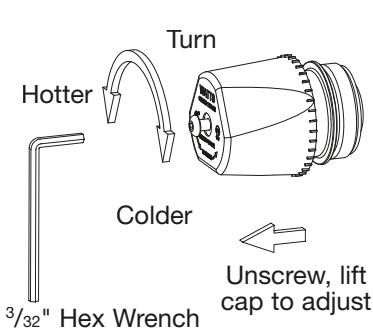

WARNING!!
Water temperatures in excess 110°F (43°C) are dangerous and may cause scalding, severe injury or death!
See the equipment's owners' manual for more details

8.2.2.1 Water Heater Maintenance

1. Disconnect AC Power prior to draining the water system.
2. Flush Tank periodically.
3. If the temperature in the tank environment is going to drop below 32 deg F (0 C), drain the tank to prevent freezing and possible damage. (See water heater owner's manual for detail)

8.2.3 Microwave and Coffee Maker

The microwave is powered with the 120 volt (230 overseas) power through the breaker marked "Microwave." There is a 120 volt (220 overseas) receptacle behind the microwave that it is plugged into. This outlet is not part of the GFI circuit. It is protected by the breaker on the MDP. Refer to microwave user's manual, coffee maker user's manual for more detail operating instruction information.

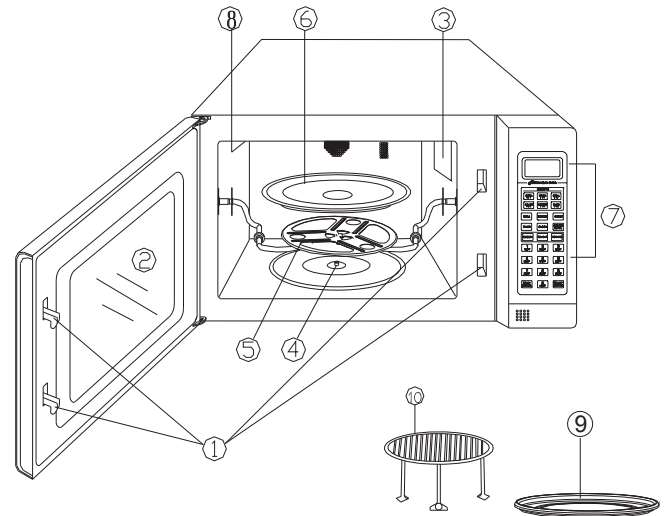

Fig. 8.3.5 shows the basic description of the microwave

1. Door Safety Lock System
2. Oven Window
3. Oven Air Vent
4. Shaft
5. Roller Ring
6. Glass Tray
7. Control Panel
8. Grill Heater
9. Baking plate
10. Baking Rack

8.2.6 Air Conditioning

The Air Conditioning system is 240 volt (230 overseas) AC powered and powered from the AC sub panel at the lower helm.

The cooling water pump is controlled by a relay at the compressor and is energized when the Air Conditioning Compressor comes on.

You can consult the Arrangement Illustration at the end of this section for location information, or see the Mechanical Arrangement in the Boating Safety Section. The Water Systems will show you the Pick-up and Strainer for this

system.



Fig. 8.4 shows one of three air conditioning unit wired remote control panels. For more detail information, please refer to the A/C owner's manual

It is very important for you to read and understand the operation and the maintenance for the systems or components in your AC Electric System. This will save failure of components or systems, as well as, make your boat a safer, more enjoyable investment.

⚠ CAUTION ⚠

Always make certain that the pick-up and discharge valves for the Air Conditioning System are opened before using. Failure to do so will cause permanent damage to your compressor. Also, be certain that the strainer is clean. See the Water Systems section for details on cleaning the Strainers.

8.3 Operations and Maintenance

8.3.1 To Operate the AC Electrical System

If you opted for the generator system, then you will, as we have mentioned, have the capabilities for two separate AC Electric systems. We will discuss the procedures for energizing both.

⚠ CAUTION ⚠

DO NOT LEAVE THE BOAT UNATTENDED WHEN SHORE POWER IS CONNECTED OR CHARGING BATTERIES

8.3.2 Shore Power

First the Shore Power System is a convenient way to obtain power should you be docked. Be sure to read the warnings posted earlier in this section on shore power safety.

1. Turn off shore power / generator selector on the breaker panel.

2. Shut down the generator if it is in operation.

3. Connect the female end of the shore power cord to your boat's shore power inlet receptacle. Be certain that the lock ring is tightly secure. If there is a cord already supplied at the dock be sure to unhook the cord from the dockside outlet.

4. Connect the shore power cable to the power supply. When connecting the shore power cable to the dockside outlet, be sure to make certain that the cable has sufficient slack to prevent stretching during tidal changes.



Fig. 8.5 the stainless shore power connector located on transom port side next to mooring cleat. the upper connector is for AC connection, and the lower connector is for TV antenna connection.

5. Select shore power on the breaker panel.

If there is no power to the electrical distribution panel (MDP), check the following:

- * Breaker switch at dockside power.
- * Main breaker switch located in the aft cabin.

8.3.3 To Disconnect the Shore Power:

1. Turn off shore power / generator selector on the aft breaker panel which located in the rudder post compartment.

2. Turn off the dockside breaker.

3. Disconnect the shore power cord from the dockside outlet.

4. Disconnect the shore power cord from the boat's shore power connection.

5. Store your cord in a safe, dry location.

⚠ DANGER ⚠

Carbon Monoxide can be harmful or fatal if inhaled. Inspect generator exhaust system for leaks at each generator startup.



DO NOT MIX WATER AND ELECTRICITY. WHILE AC ELECTRICAL POWER IS POTENTIALLY DEADLY IN ANY LOCATION, IT IS ESPECIALLY DANGEROUS IN AND AROUND THE WATER.

8.3.4 Generator Start-up

1. To gain access to the generator, remove engine box access doors. Check generator for signs of fuel or oil leaks. If your boat has diesel engines, check the fuel filter.
2. Check area for fuel fumes. If you detect fuel fumes:
 - a. Evacuate the boat immediately
 - b. Notify the dock, fire department, or Coast Guard of the condition.
 - c. Open all hatches, doors, and ports for natural ventilation.
 - d. When you can no longer smell fumes, locate the source. Using a hand held pump, carefully remove any fuel from the bilge. Dispose of this fuel in a safe, approved location.
3. If you do not smell fuel fumes, make sure fuel shutoff valve on fuel line to generator is open.
4. Check generator oil level. Refer to the generator manual for instructions. Add oil if necessary.
5. Check generator coolant level. See generator manual for instructions.
6. Open generator seacock. Valve is open when the handle is in line with hose. Seacock is located forward of the generator sea strainer.
7. At main breaker, make sure all breakers are off.
8. Consult your Generator OEM manual for proper start up procedures.

9. Check for water coming from the exhaust outlet pipe. Water flowing from the pipe indicates the water is circulating through the generator cooling system. You should see water flowing shortly after generator starts.

10. Inspect the exhaust system for leaks. If you detect leaks or smell fumes, shut down the generator immediately. Do not restart the generator until you have corrected the problem.

11. Allow the generator to warm up before connecting a heavy electrical load. Keep the load within the nameplate rating.

Note: Infrequent use of the generator may result in hard starting. For detailed start-up information, refer to the generator operating manual.

8.3.5 To Start the Generator System Generator Basic Operating Instruction:

Routine “pre-start” checks:

- 1 Check oil level.
- 2 Engine cooling system (all valves open).
- 3 Power source selector switch (off/shore power/generator power). Switch to power source switch “OFF”, or switch off all consumers in the usual way. If a Mass Systemswitch is installed, this operates automatically.
- 4 Switch on battery switch.
- 5 Fuel valve: open.

Starting:

Push the start button to initiate the full automatic starting procedure. You can monitor the procedure on the display.

In operation checks:

- 1 Check for abnormal noise or vibration
- 2 Check the voltage
- 3 Check sea water flow at exhaust outlet
- 4 Power source selector switch (off/shore power/generator power). Switch to power source generator. If a Mass Systemswitch is installed, this operates automatically.
- 5 Before loading the generating set up to maximum, have

it run warm. Continuous load should be restricted to 70 % of maximum load.

Stopping generator:

- 1 Switch off all electrical devices (consumers). If the generating set has been running under full load for a longer period, do not shut it down abruptly. Reduce the electrical load to about 30% of the rated load and let it run for approx. 5 minutes.
- 2 Press the STOP button.
- 3 Close the inlet sea water cock.
- 4 Switch to an other AC power source, if available. If a Mass Systemswitch is installed, this is done automatically.

8.3.6 The Air Conditioning System (Option)

There are three air conditioning units installed on your boat. Ensure that you read the instructions on the air conditioner’s owner’s manual for more detail operating information.

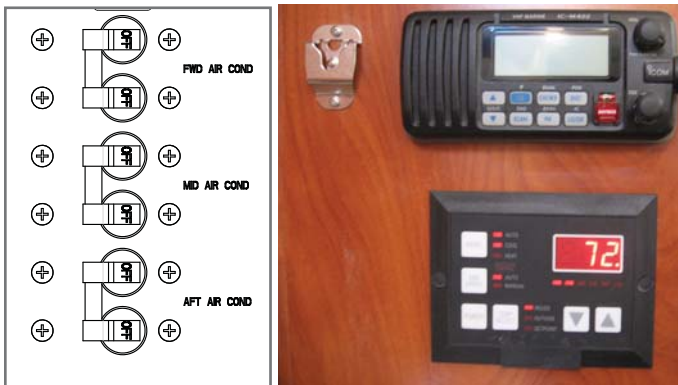

Fig. 8.6 Air conditioner breakers on AC control panel. the air conditioner control panel on main cabin navigation station

1. Ensure you have 240 volt (230 overseas) power to the MDP.
2. Check to make sure that the seawater intakes, and discharge for the A/C system cooling is open and that the strainer is clean and debris free.

3. Energize the Air Conditioning system at the MDP panel.
4. Check to make sure that the discharge is flowing at the Air Conditioning cooling water discharge.

General Operation:

The A/C unit reverse cycle air conditioner has both a heating and cooling mode of operation. It uses R-22 or R407c refrigerant in a conventional vapor compression cycle to transfer heat from the air in the boat to the water. In the cooling mode, a blower blows the cabin air through the indoor or evaporator coil where it is cooled and dehumidified. Liquid refrigerant passing through the evaporator is boiled into a gas by heat removed from the air. The warmed refrigerant gas enters the compressor where its temperature and pressure are increased. The hot refrigerant gas travels to the water coil or condenser where it is cooled by the water and condenses to a liquid. Liquid refrigerant is metered back into the evaporator coil to repeat the process.

In the heating mode, the process is reversed. A special reversing valve reverses the flow of the refrigerant throughout the system exchanging the roles of the condenser and evaporator. The refrigerant flows through the water or evaporator coil, picks up heat from the water, and becomes a vapor. The vapor then enters the compressor where it is compressed to a higher temperature. It is then pumped to the indoor coil where the air moving across the coil picks up the heat and the warm air is blown into the room. The compressed refrigerant vapor condenses to a liquid as it gives up heat. Finally, liquid refrigerant flows into the capillary tubes into the indoor coil where the cycle is repeated.

The reverse cycle air conditioner is controlled by a controller mounted on the main cabin navigation station, port side aft engine bulkhead in aft cabin and above port hanging locker in the forward cabin.

Please refer to air conditioner’s owner’s manual for detail information regarding operating of the A/C unit and maintenance information.

Hunter 50cc • AC Electric Systems

Troubleshooting		
Problem	Possible Cause	Solution
No AC power	Main breaker(s) aft cabin tripped or off Shore power cord not connected Loose or disconnected wire	Turn breaker on or reset Check cord, plug in if necessary Tighten connections. See your dealer
No power to AC devices	Breaker(s) at AC control Center tripped or off Shore power cord not connected Loose or disconnected wire	Turn breaker on or reset Check cord. Plug in if necessary Check cord. Plug in if necessary Tighten connections. See your dealer
Inadequate power to AC devices (generator running)	Electrical demand greater than generator output	Switch off devices and equipment not needed Switch PARALLEL breaker off to reduce demand Use shore power AC line if available
Continuous tripping of main breaker	Cause of problem not corrected	Determine cause and correct problem before resetting breaker See your dealer if problem persists
Generator will not start	Battery discharged or dead	Recharge or replace battery
No power at AC outlets	Outlet breaker in AC control center OFF Ground fault interrupter tripped	Switch breaker to ON Reset button on outlet and test



H U N T E R[®]

MARINE CORPORATION

AN EMPLOYEE OWNERSHIP COMPANY

We Go The Distance

Chapter 9

Water Systems

Hunter 50cc



The fresh and raw water systems consist of the following components:

- Dockside Water Supply
- Fresh Water Tanks and Fills
- Fresh Water Pump
- A/C Cooling Pump
- Raw Water Pick-up and Strainer
- A/C Pick-up and Strainer
- Generator Cooling Pick-up and Strainer
- Engine Seacocks and Strainers
- Fixtures and Valves
- Water Heater

9.1 Dockside Water Supply

When you are docked, you can connect a pressurized dock water supply to your boat. A dockside water supply will pressurize the boat's water system without using the water pumps. The dockside system is connected after the water pump which then will act as the check valve.

The dockside water inlet is standard on the transom. Connecting a portable (drinking) water hose from a local water source to this inlet provides water under pressure to the fresh water system without using the pumps.

Dockside water often comes from a municipal water supply or similar sources which supplies water at a higher pressure than the boat's onboard system pressure. The pressure regulator on the water inlet reduces the pressure of the dockside supply to match the boat system's lower pressure which is normally around 35 psi.

This dockside water does not fill the water tanks.

Important: Always disconnect the dockside water supply when you leave your boat unattended. A major leak or break in the system could flood your boat. Excess water in the bilge may sink your boat or flood the batteries and engine. Your warranty does not cover this damage.

Note: Before you connect your boat's water system to the dockside water supply, make sure the dockside water supply is suitable for drinking. Check with the dockmaster to be sure.

9.1.1 To connect the potable water inlet to your boat's water system:

1. Connect a drinking water hose to the potable water supply.
2. Connect the other end of the hose to the potable water

spigot.

3. Open the cold water faucet closest to the potable water inlet on the boat.

4. Open the potable water supply spigot. As soon as a steady stream of water comes out of the faucet on the boat. Close the spigot.

5. Check the boat's water system for leaks. This inspection is particularly important when you use the potable water hookup the first time.

The fresh water system is now ready for use.

9.2 Water Tanks (on board water supply)

The fresh water system on your boat has three water tanks and three fresh water fills located on the starboard midship on deck. The vent for each tank is located on the side of the hull, at each fill. There is an isolator valve which allows you to select which tank is supplying water.



Fig. 9.1

Note: Whenever servicing the fresh water pumps, shut off the DC breaker for the water system.

9.2.1 To fill the fresh water tank:

1. Make sure the potable water supply is suitable for drinking. Not all potable water is drinking water. Check with the dockmaster if necessary.
2. Open the water tank fill fitting. Fig. 9.1
3. Using the hose from the potable water supply, fill the tank until water starts flowing through the vent.
4. Close the fill fitting.



Always ensure that when filling the fresh water tanks that you are filling through the fresh water fill. Other fills or pump outs may visually look the same. Filling fresh water in to the waste pump out could flood your boat, or filling the diesel fuel tank could damage your fuel system.

9.2.2 Fresh water sanitation

NOTE: Be sure and read the OEM manuals that are supplied with your boat, the next section is taken from one of those manuals.

Sanitizing Potable water systems require periodic maintenance to deliver a consistent flow of fresh water. Depending on use and the environment the system is subjected to, sanitizing is recommended prior to storing and before using the water system after a period of storage. Systems with new components, or ones that have been subjected to contamination, should also be disinfected as follows:

NOTE: The sanitizing procedure is in conformance with the approved procedures of the US Public Health Service.)

1. Use the following methods to determine the amount of common household bleach needed to sanitize the tank:
 - A. Multiply “gallons of tank capacity” by 0.13; the result is the ounces of bleach needed to sanitize the tank (30 gallons X .13 = 3.9 oz bleach).
 - B. Use the number of liters of tank capacity to determine the number of milliliters of bleach needed to sanitize the tank (120 liters of tank capacity = 120 milliliters of bleach).
2. Mix into solution the proper amount of bleach within a container of water
3. Pour the solution (water/bleach) into the tank and fill the tank with potable water.
4. Open all faucets (hot and cold) allowing the water to run until the distinct door of chlorine is detected.
5. The standard solution must have four (4) hours of contact time to disinfect completely. Doubling the solution concentration allows for contact time of one (1) hour.
6. When the contact time is completed, drain the tank. Refill with potable water and purge the plumbing of all sanitizing solution.

9.2.3 Fresh Water Manifold

The fresh water manifold is basically a diverter for the separate water systems aboard your boat. It has both a cold water and a hot water side to it and is made up of a supply line that supplies the water to the manifold. The manifold is then separated into lines that feed the various systems.

Usually centrally located in the galley, it allows the owner some control over which branches of the water system are being supplied.

Later in this chapter (Fig. 9.6) you will find a photo guide to the Fresh Water Manifold with some instructions on its use.

The actual look or shape of your manifold may vary some from the photo on Fig. 9.10, however the manifold operations will be the same.

The manifolds vary depending upon the options or equipment installed on your boat.



Fig. 9.2

Note; Examine the differences between the hot, and cold water lines in Fig. 9., you will notice that the cold water lines are blue while the hot water lines are red.

9.3 Pumps

On board your boat there are both fresh water and raw

Hunter 50cc • Water Systems

water pumps that control the flow of water to the related components. These are electrically powered pumps . Some of the features of these pumps are:

- Smooth Flow
- Self-Priming up to 10 feet (3m)
- Dry running capability
- Soft noise absorbing mounts
- Snap-fit port fittings
- Built-in bypass — less pulsation
- Reduces need for accumulator tank
- Corrosion resistant materials

Remember to read your OEM manuals for complete information, as well as safety warnings, or notices.

9.3.1 Fresh Water Pump

The fresh water pump supplies water to the system under pressure when the potable water supply is not connected.



Fig. 9.3. Replace the strainer periodically for better performance of the entire fresh water system. The water pump unit with strainer locates underneath the galley shelf.

The water pump with water strainer locates underneath the galley shelf. The WATER PUMP breaker switch is on the DC side along with the remote switch on the AC/DC control panel. When the breaker is switched to ON, the pumps will run until the hot and cold water systems are pressurized. An automatic pressure switch shuts the pumps off until the pressure drops to a preset level (for example, a pressure drop caused by opening a faucet). The pumps will then run again until the system is pressurized and turn itself off. The pumps have a built-in check valve to prevent backflow through the pumps.

To prime the plumbing system, open all the faucets and turn on the power to the pump. Shut off each faucet as it begins to run free of air. As the last faucet is closed the pump will slow down and shut off. (See OEM packet the equipment's owner's manual for more details on the operating instructions)



Fig. 9.4

The fresh water washdown connection is located on the transom.

Important: Operate the fresh water pumps only when there is water in the tank. Running the pumps dry will damage the diaphragm.

Note: If the pumps run from time to time even though no water is being used, a leak in a water line is a likely cause. Check all lines for leaks and repair immediately.

9.3.2 A/C Cooling Pump (Option)

Your boat may be equipped with the optional air conditioner reverse cycle unit. This type of unit can heat or cool your boat.



Fig. 9.5

The Air Conditioning system is made up of a pickup valve (or thru hull) (See Underwater Gear for its location), a sea strainer, an A/C cooling pump, and the major compressors and air handlers.

To find the A/C cooling pumps locates in the main bilge where next to thru hull fitting's.

The A/C cooling pump receives sea water from the pick-

up strainer and pumps it through the A/C compressor to cool the compressor.

See the AC Electric Section for an explanation of the electrical controls of this system.

9.3.4.1 To operate the air conditioner:

1. Open the air conditioner seacock. The valve is open when its handle is in line with the hose. The seacock is located to the aft bilge compartment, aft of the A/C pump, in the bilge.
2. Check the strainer. Clean if necessary to assure a steady flow of water to the unit.
3. Set the thermostat to the temperature desired. The thermostat is located next to the MDP.

Important: Be sure to close air conditioner seacock when the air conditioner is not in use. Refer to the manufacturer's owner's manual furnished with the air conditioner for more information regarding its operation.

9.3.3 Toilet water supply

The toilet aboard your boat is supplied with flushing water from the fresh water system.

More information concerning the operation and maintenance of this system can be found in the Waste and Sanitation chapter, Chapter 10 of your Operator's Manual.

9.4 Pickups and Strainers

There are various pickups and strainers installed aboard your boat. Here we will discuss the pick-ups and strainers associated with the water systems.

9.4.1 Pick-ups

Pick-ups, or through hulls are placed in various locations in the hull of your boat. The intakes usually have a ball type valve which controls the flow of raw sea water to the specific component, or system associated with the pick-up.



It is very important that you ensure that the intake valve is open before using a raw water supplied system. Failure to do so could damage or break down a

system or component.

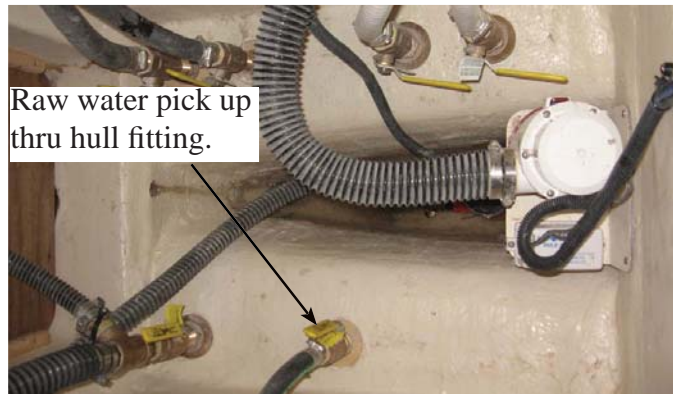

Fig. 9.6 the figure shows the location of air conditioner raw water pick up thru hull fitting with ball valve.

9.4.2 Strainers

Your boat is equipped with strainers that strain the raw water taken in the thru hulls or pickups for objects that could damage the impeller or pump equipment. Strainers are equipped with a screen or a filter inside that collect objects taken in. They must be cleaned as part of routine maintenance.

To clean a strainer, first, make sure that the supply valve is in the Off or closed position. Failure to close the intake or seacock could result in a flooded boat. Next, remove the "collector" or glass encasement that houses the screen. Remove any objects collected inside and wash the screen.

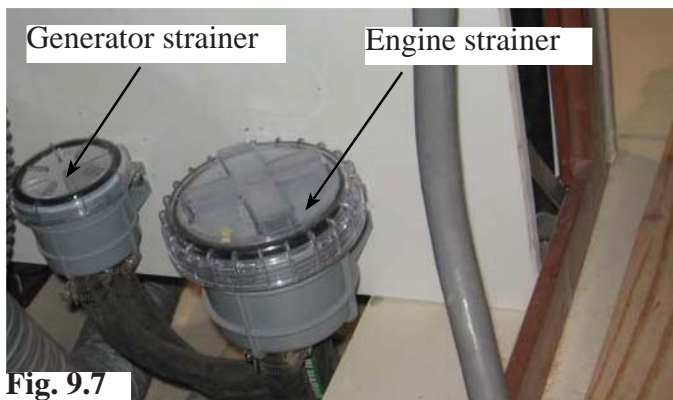

Fig. 9.7

9.4.3 A/C Pickup and Strainer (Air Conditioning Option)

At the end of this section, you will find an illustration of the A/C cooling water arrangement. It is important to always ensure that the intake valve (see mechanical arrangement in the Boating Safety Chapter, as well) is always open before using the A/C System. In the pumps subsection of this chapter you will see the image of these components.

If you purchased your boat with the air conditioning option, you will find the documentation for the operation of this system in the owner's packet of the manufacturer's owner's/operator's manuals.

9.4.4 Generator Cooling Pickup and Strainer (Generator Option)

The generator is an engine and, just like the main engines, requires cooling water. Water is supplied to the generator through the intake and strainer located just aft of the generator. Raw water is taken in via the raw water intake and then passes through the strainer and is discharged through the exhaust of the generator. (See Generator Owner's Manual for more details)

9.4.5 Engine Seacocks and Strainers

It is a very important function for your main engines to remain a specific temperature when operating. This is done with the aid of raw water from the main engine seacocks. Heat from the closed cooling system on the engines is transferred to the cooler seawater through heat exchangers inside the engine. The raw water is then discharged through the exhaust.

To clean your main engine strainer, first close the main engine seacock, remove the top cover on the strainer remove the screen and clean.



Always ensure engine, or generator seacocks, or intakes are open before starting. Failure to do so could overheat and a damage these components.

Before re-installing the cap onto the strainer, check the 'o' ring that is the seal on the cap. Check for wear, or leakage. Replace if needed (Contact your dealer for replacement).



Hot coolant under pressure may boil or explode and

cause burns or other personal injury when the pressure cap is removed. Allow the engine to cool, then open the cap slowly to allow any pressure to vent before completely removing the cap.



Before using any system that requires raw cooling water, ensure that the intake valve is opened and the strainers are not clogged. Section 9.4.6 illustrates the procedure for cleaning your strainers.

9.4.6 Water Heater

The fresh water pump supplies water to the water heater from the water tanks. A breaker on the AC side of the MDP, and a rocker switch on the control panel controls power to the heater.

Follow these procedures when using the water heater:

1. Make sure the water heater is full of water. Open a hot water faucet and allow a steady stream of water to flow out of the faucet to remove all air from the hot water circuit.
2. With the generator running or shore power connected to your boat, switch on the WATER HEATER circuit breaker at the AC side of the MDP.
3. Wait for the water in the tank to heat up, then use as you would at home.



IMPORTANT!

Water temperatures in excess 110°F (43°C) are dangerous and may cause scalding, severe injury or death

9.4.6.1 Water Heater Temperature Adjustment (Thermostatic Mixing Valve)

1. Let the water flow for at least 2 minutes to allow supply temperature to stabilize.
2. Calibrate the mixed water outlet temperature by placing a thermometer in the mixed water stream.
3. To adjust the setting of the valve, loosen locking cap with hex wrench, see figure 9.5.0. Cap must be lifted 1/4" to adjust temperature. To increase the temperature, turn counterclockwise. To decrease temperature, turn clockwise.

4. Lower handle and tighten screw.
5. Check outlet temperature.

NOTE: Refer to User’s manual in OEM Packet.

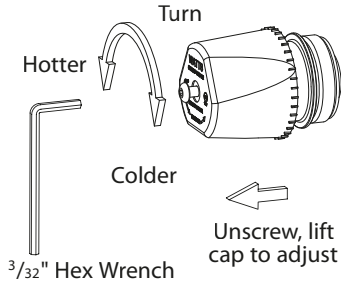

Fig. 9.8

**Table 1. Scald Time (Hot Water), References Only
Temperature Max duration until injury**

155F (68.3C)	1 second
145F (62.9C)	3 seconds
135F (57.2C)	10 seconds
130F (54.4C)	30 seconds
125F (51.6C)	2 minutes
120F (48.8C)	5 minutes

! WARNING !

Hydrogen gas may form in water heater if not used. Open valves. Do not smoke or use electrical appliances for several minutes before use.

Note: Actual water manifolds may vary in detail from the one pictured above. The manifold is based upon the amount of components, or systems being fed from the manifold.

Note that the manifold is made up of an Inlet, an outlet and valves located on each outlet. As noted the valve is tagged with a color coded washer to allow you to determine if the line is a “Hot” water line or a “Cold water line.



Fig.9.9

In Fig 9.9 shows by turning the control knob line-up with fitting to open the valve and turing the knob perpendicular with the fitting to close the valve.

! DANGER !

You should always be aware if the valve to the water heater is opened or closed. This should never be closed if there is a possibility of the water heater being energized. This could cause damage to your water heater.

! WARNING !

Leaving your boat unattended with the systems on water manifold on can sink your boat. If a leak developed while attached to a water source, or dockside supply. This could sink your boat! Always close all valves when leaving your boat attached to a dockside water supply while unattended!

Hunter 50cc • Water Systems

Troubleshooting		
Problem	Cause	Solution
Air in system	Tank empty	Fill all water tanks
Fresh water pumps cycle on and off	Tank empty Blocked or pinched water lines Loose electrical connections Defective pumps Leak in system	Refill Clear obstruction or straighten line Check connections. Tighten as needed See your dealer for service See your dealer for service See your dealer for service Repair leak. See your service dealer for repairs
Low water pressure at all sinks and showers	Defective pumps	See your dealer for service
Low water pressure at one sink	Pinched water line	Straighten line
No hot water (AC Power)	Water heater breaker OFF	Switch breaker to ON

50cc FRESH WATER SYSTEM ARRANGEMENT

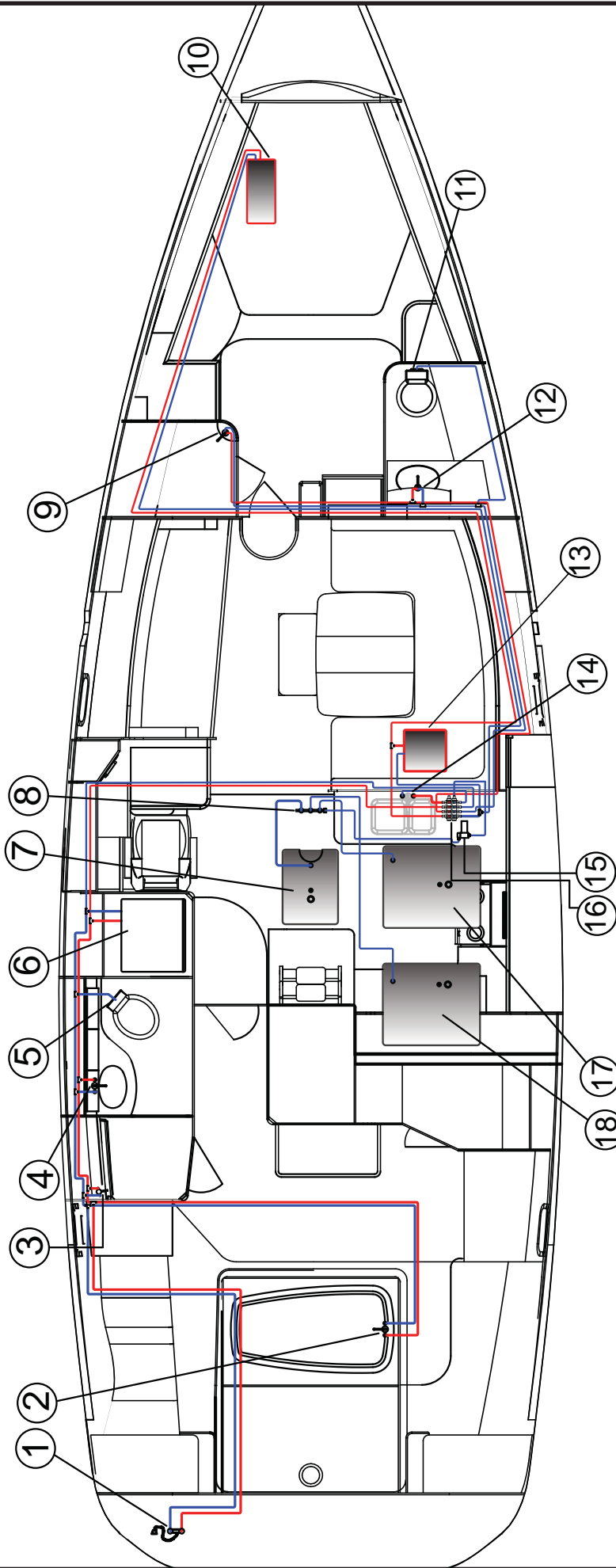

- 1. COCKPIT SHOWER (COLD & HOT)
- 2. AFT CABIN BATH TUB FAUCET (COLD & HOT)
- 3. MASTER SHOWER FAUCET (COLD & HOT)
- 4. MASTER VANITY FAUCET (COLD & HOT)
- 5. MASTER HEAD (COLD)

- 6. OPTIONAL WASHER AND DRYER (COLD & HOT)
- 7. CENTER WATER TANK (COLD)
- 8. WATER TANK MANIFOLD (COLD)
- 9. PORT GUEST SHOWER FAUCET (COLD & HOT)

- 10. FWD CABIN WATER HEATER
- 11. STARBOARD SIDE GUSET HEAD (COLD)
- 12. STARBOARD VANITY FAUCET (COLD & HOT)
- 13. WATER HEATER
- 14. GALLEY FAUCET (COLD & HOT)

- 15. FRESH WATER PUMP (UNDER GALLEY SINK)
- 16. GALLEY MANIFOLD (UNDER GALLEY SINK)
- 17. STARBOARD FWD WATER TANK
- 18. STARBOARD AFT WATER TANK

CAUTION ▲

Make sure that the water heater is full before energizing, bleed off any air by opening the hot water valve, close only when there is a steady flow of water, this will bleed the hot water system of air. Failure to follow these instructions could result in damage to the heating elements in your water heater.

WARNING ▲

Allowing your boat to stay connected to dockside water supply while unattended, could result in a sunken boat. A major leak or break in the system could flood the bilges, excess water in the bilges could, flood the batteries and result in your boat sinking.

Before connecting to a dockside water source make certain the water is suitable for drinking. Water that may be of questionable quality could result in serious illness or death.

Hydrogen gas may form in a water heater if not used. You should always open the valves!

Do not smoke or use electrical appliances for several minutes before use.



50cc FRESH WATER TANK ARRANGEMENT

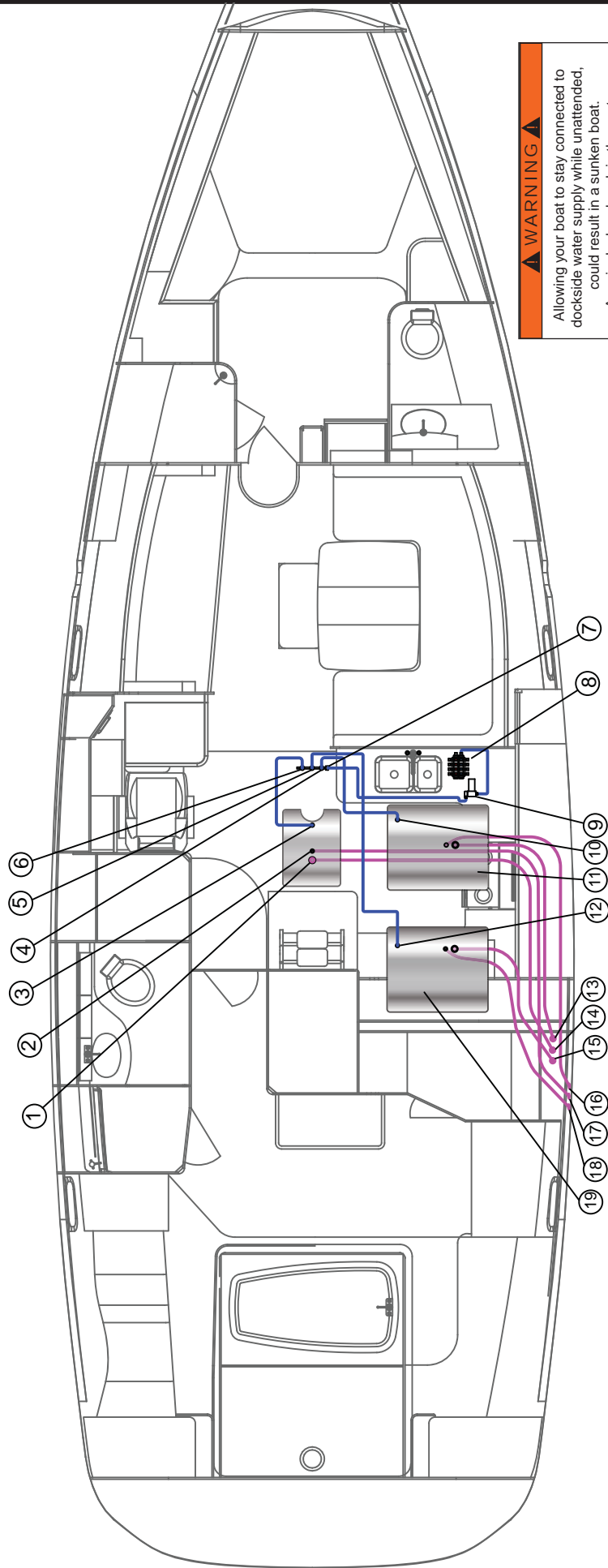

- 1. CENTER WATER TANK FILL FITTING
- 2. CENTER WATER TANK VENT FITTING
- 3. CENTER WATER TANK FITTING
- 4. STARBOARD FWD TANK SHUT OFF VALVE
- 5. STARBOARD AFT TANK SHUT OFF VALVE
- 6. CENTER WATER TANK SHUT OFF VALVE
- 7. COMBINED TANK WATER FEED ON MANIFOLD
- 8. COLD WATER INLET ON GALLEY MANIFOLD
- 9. FRESH WATER WATER PUMP

- 10. STARBOARD FWD WATER TANK FITTING
- 11. STARBOARD WATER TANK
- 12. STARBOARD AFT WATER TANK FITTING
- 13. STARBOARD FWD TANK FILL FITTING ON DECK
- 14. CENTER WATER TANK FILL FITTING ON DECK
- 15. STARBOARD AFT TANK FILL FITTING ON DECK
- 16. STARBOARD FWD TANK VENT THRU HULL FITTING
- 17. CENTER WATER TANK VENT THRU HULL FITTING
- 18. STARBOARD AFT WATER TANK VENT THRU HULL FITTING
- 19. STARBOARD AFT WATER TANK

CAUTION

Make sure that the water heater is full before energizing, bleed off any air by opening the hot water valve, close only when there is a steady flow of water, this will bleed the hot water system of air. Failure to follow these instructions could result in damage to the heating elements in your water heater.

WARNING

Allowing your boat to stay connected to dockside water supply while unattended, could result in a sunken boat. A major leak or break in the system could flood the bilges, excess water in the bilges could, flood the batteries and result in your boat sinking.

Before connecting to a dockside water source, make certain the water is suitable for drinking. Water that may be of questionable quality could result in serious illness or death.

Hydrogen gas may form in a water heater if not used. You should always open the valves!

Do not smoke or use electrical appliances for several minutes before use.



50CC GALLEY WATER MANIFOLD ARRANGEMENT

CAUTION ▲
 Make sure that the water heater is full before energizing, bleed off any air by opening the hot water valve, close only when there is a steady flow of water, this will bleed the hot water system of air. Failure to follow these instructions could result in damage to the heating elements in your water heater.

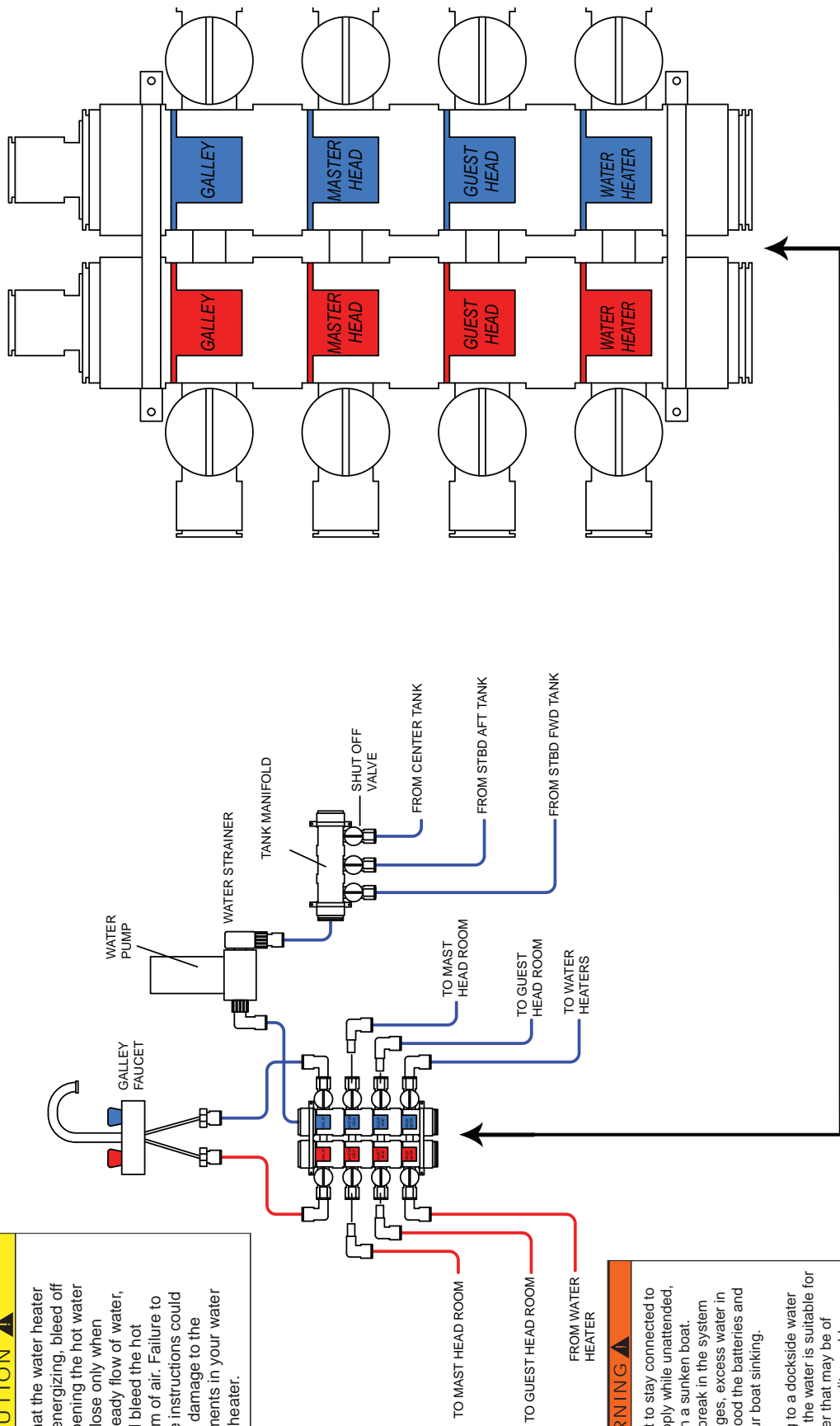

WARNING ▲
 Allowing your boat to stay connected to dockside water supply while unattended, could result in a sunken boat.
 A major leak or break in the system could flood the bilges, excess water in the bilges could, flood the batteries and result in your boat sinking.
 Before connecting to a dockside water source, make certain the water is suitable for drinking. Water that may be of questionable quality could result in serious illness or death.
 Hydrogen gas may form in a water heater if not used. You should always open the valves!
 Do not smoke or use electrical appliances for several minutes before use.



50cc AIR CONDITIONING PLUMBING ARRANGEMENT

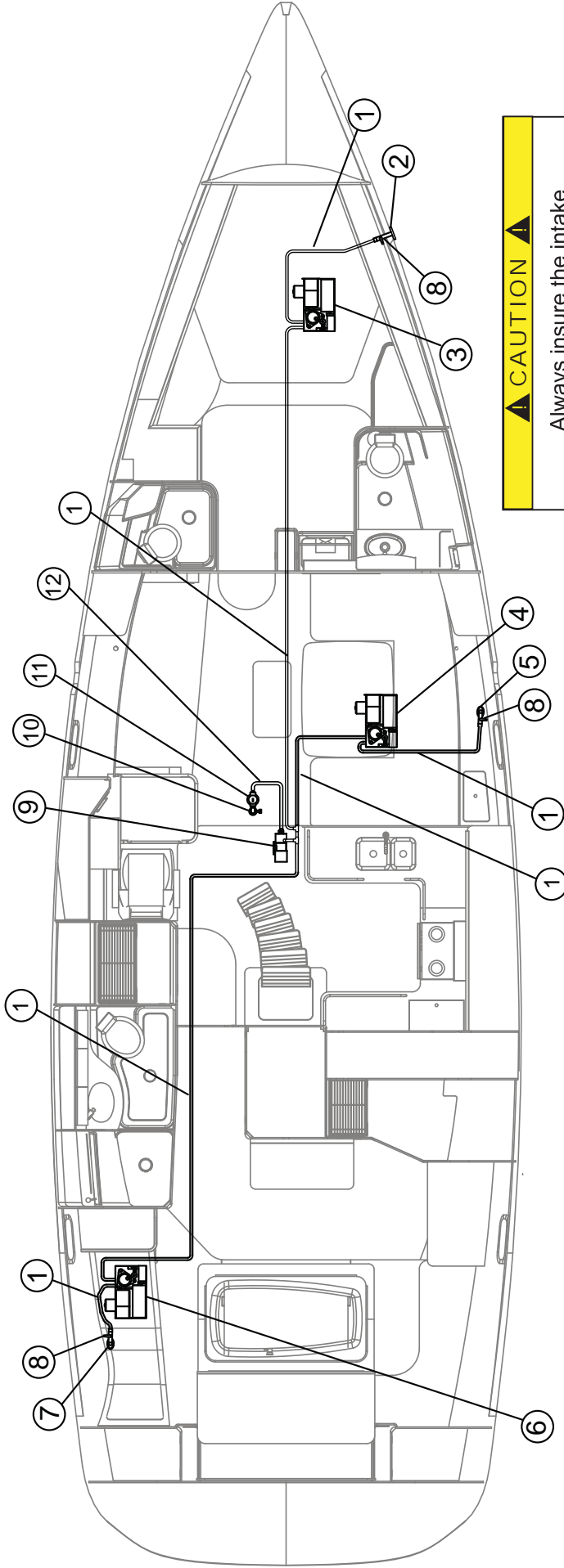

1. AIR CONDITIONER FEED DISCHARGE HOSE (Ø5/8" HOSE)
2. FWD CABIN AIR CONDITIONER DISCHARGE THRU HULL FITTING (Ø1/2")
3. 10K BTU FWD CABIN AIR CONDITIONER UNIT
4. 16K BTU MAIN CABIN AIR CONDITIONER UNIT
5. MAIN CABIN AIR CONDITIONER DISCHARGE THRU HULL FITTING (Ø1/2")
6. 16K BTU AFT CABIN AIR CONDITIONER UNIT
7. AFT CABIN AIR CONDITIONER DISCHARGE THRU HULL FITTING (Ø1/2")
8. BALL VALVE (Ø1/2")
9. AIR CONDITIONER RAW WATER PUMP
10. AIR CONDITIONER RAW WATER PICK UP THRU HULL FITTING (Ø3/4")
11. RAW WATER STRAINER (Ø3/4")
12. AIR CONDITIONER RAW WATER PICK UP HOSE (Ø3/4")

▲ CAUTION ▲

Always insure the intake valve for the AC pump is open before using the AC system

Never leave the intake valve open while the boat is unattended.
A major leak or break in the system will flood your boat!

Make sure you are aware of the laws for dumping waste overboard.





HUNTER®

MARINE CORPORATION

AN EMPLOYEE OWNERSHIP COMPANY

We Go The Distance

Chapter 10

***Waste
Systems***

Hunter 50cc



This section outlines the use, care, and maintenance of your boat's sanitary systems, as well as, bilge pumps and waste systems.

Important: U.S. Coast Guard regulations require that boats have a sanitation system on board to control pollution. Waste is to be stored in a holding tank or other device so it can be properly disposed of at a shore facility. Discharging this waste overboard in U.S. lakes, rivers, bays, and sounds, and within three miles of shore in international waters is prohibited. Check with the Coast Guard regarding regulations in your area.

Sanitation Systems

Your boat has a sanitation and bilge system that is the cutting edge of sanitation. The components are designed to fit the most demanding environment. Some of the following components are listed in the Sanitation and Bilge Section.

- Head Systems
- Drains
- Pumps
- Holding Tank
- Macerators
- Shower Sump

In this section, we will break the systems down into a format to help you better understand how your systems work and what it takes to maintain them. These systems are further divided into four types of discharge, Gray water, Black water, Raw water, and Gaseous discharges. The gray water system is comprised of waste that is not considered raw sewage, which is categorized as Black water. Raw water is the cooling water that is taken in through pickups, etc. and discharged back. Gaseous discharges are your exhaust, or fuel vents. Parts of the sanitation systems are Drains / Discharges, Pumps, Holding Tanks / Sumps, the lines or hoses that feed or drain these systems, and the components that make up the collective point for waste, and the access point for sanitation.

10.1 Drains / Discharges

Most drains are in the form of through hulls or overboard discharges. These fittings connect to a component, or line, that is routed from a collection point or point of waste origin. Any waste outlet that is gravity fed would be called a drain. Likewise, anything that was fed by a pump would be called a discharge.

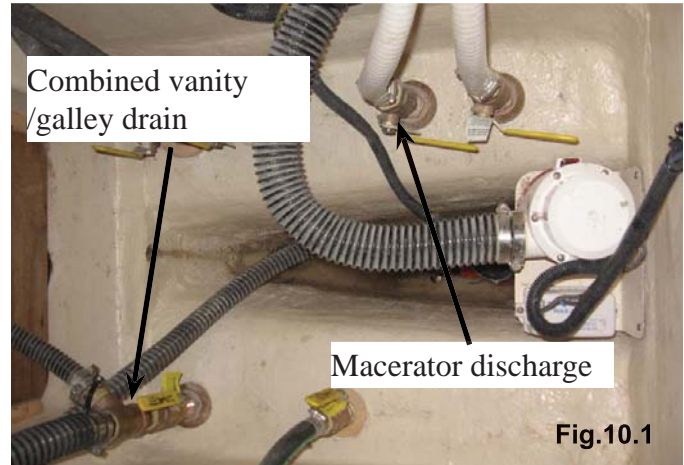

However, waste is not limited to liquids, so, an example might be the exhaust system on your engine or generator. This system disposes of the Carbon Monoxide gas through the exhaust system.

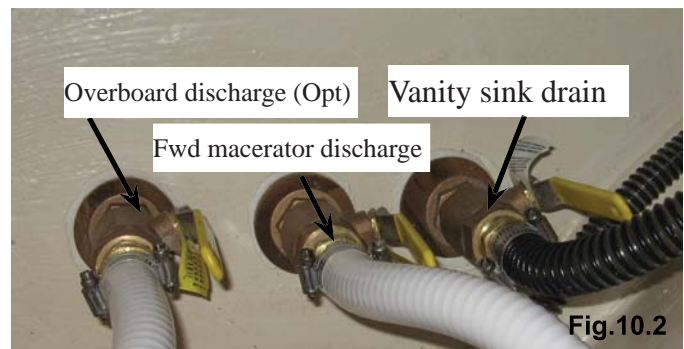

In this section, we will cover all the types of drains and discharges aboard your boat, give you the details of how they work, and the information so you can maintain these components.

10.1.1 Through Hulls

There has to be an outlet or a way to discharge the liquid waste. These are called through hulls, and they are openings in the hull or sides of your boat with bronze fittings. These are fitted to drain hoses and sized to be compatible with the system that they drain. At the end of this section, you will find illustrations showing you the locations of your through hulls and their specific function. The hoses that feed the through hulls on your boat are looped over the fitting in order to prevent any water or waste from leaking or draining back into your boat. Fig. 10.1 and fig. 10.2 give you a look at some through hulls. Vents, also shown in Fig. 10.2, are another type of through hull and, yet another type of waste disposal.

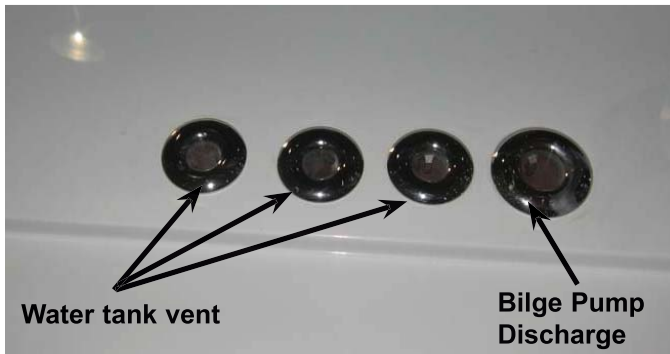

Fig. 10.3 shows starboard side sheer thru hull fittings locate above feature line

These are limited to allowing over flow or air to escape the fuel and the holding and water tanks aboard your boat. This is one way that gaseous waste products, as well as in some instances, liquids are disposed. However, you should always avoid using the fuel tank vent as a way to tell if your tanks are getting full when fueling. Fuel spills are a dangerous hazard. (See the Fuel Section of this manual).

Any waste outlet (**macerator discharge thru hull fittings, ball valve and sanitation hoses**) that is gravity fed would be called a drain. Likewise, any that was fed by a pump would be called a discharge.

10.1.2 Overboard Discharge

Some discharges have valves associated with them. The Black water, or Raw sewage system from the head is one such system.



Fig. 10.4 shows overboard discharge valve as part of overboard discharge system

The overboard discharge overboard discharge valve locates near the macerator pump where in the forward

discharge bilge compartment, and the aft Y valve locates on platform by macerator unit, This is a ball type valve in which the chopped solid waste from the holding tank is disposed of after passing through the macerator.

Basically, all pumps are somewhat associated with the Waste / Sanitation system, but in this section we will focus on the pumps that are directly associated with the process of pumping waste overboard. The supply function of these pumps are discussed in other sections.

Note: The Overboard Discharge Valve should remain closed at all times except when in use.

10.2 Pumps

Probably the most important pump system on your boat is the bilge pump system. Your boat is supplied with one bilge pump and one high velocity emergency bilge pump. All are part of the Gray water system. This emergency bilge pump has the pumping capacity of 66 gallons a minute from your bilges. Your other bilge pumps vary according to boat model and size, please refer to the documentation for your bilge pumps for the pumping capacities.

We are concerned about your safety. You should review all information contained in this manual, as well as, the manufacturer's manuals concerning all systems on your boat, but the bilge pump system will be one that is crucial to learn. These pumps have the function of clearing water from the bilges of your boat. You must ensure that they are kept clean and functional in order for these pumps to complete that task.

10.2.2 Emergency Bilge Pump

The emergency, or High Water Bilge pump, is generally located in the center bilge compartment of your boat. It is mounted about 12" off the bottom of the bilge. This is why it is referred to as a High Water Pump. We discussed in the DC Electric section about the float switch and the operation of the pump, so, you already understand that the water level has to be above a high water level to operate this pump. Fig. 10.2 gives you a look at the emergency bilge pump aboard your boat.

Should the water level rise above the high water mark, and the emergency bilge pump comes online, you will hear a high water alarm from the helm along with a solid red light. It would also be important to mention here that

when you hear the high water alarm (Fig. 10.3), it means that high water exists in the bilges and it is time to take action. Refer to the “Chapman’s Piloting, Seamanship and Boat Handling.” We have supplied you with a copy of this book aboard your new boat, but if you do not have one, it is a wise idea to purchase this boating manual. It is full of useful safety and navigational information.

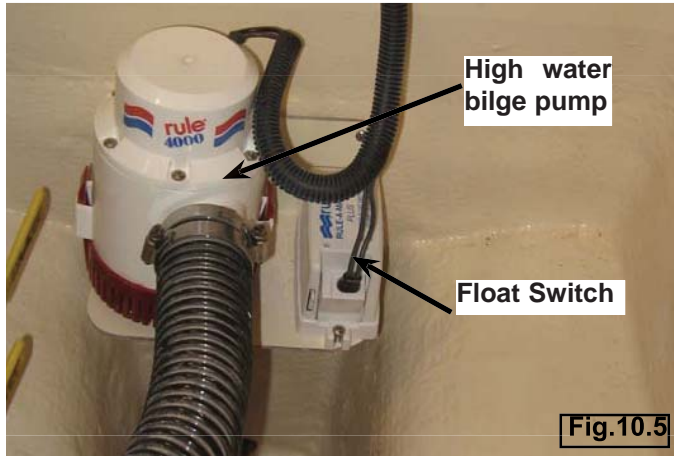

Fig.10.5

Check your Mechanical Arrangement illustration in the Boating Safety Section for the location, and the Waste / Sanitation illustration at the end of this section, for the discharge hose routing for this or any pump.

10.2.3 The main Bilge Pump

This pump is located in the lowest parts of the bilge. The function of this pump is to clear the water before it reaches the high water level.



Fig.10.6 shows the main bilge pump locates in main bilge compartment

Careful maintenance should be made to these systems to ensure they are always operational. Check the DC Electric Section, or the Operation and Maintenance

subject of this section, to find the details about operation of these pumps and the details of how to manually run them.

10.2.4 Forward and Aft Shower Sump Pump

Another pump that incorporates the float switch / pump system is your shower sump pump. Due to the level of the shower drain, we have installed a pump system to rid the boat of water from your shower. The small holding tank also acts as a collection point for hair and other waste materials that might get washed down the shower drain.



Fig. 10.7 Aft Shower Sump Pump

As in the bilge pumps, when the water reaches a certain level in the sump box, the float energizes the pump and clears the water. Refer to the Operation and Maintenance subject of this section for details on the servicing or maintenance of the shower sump.

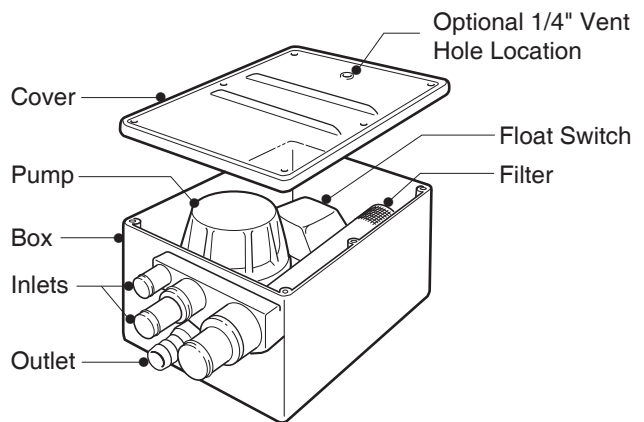

Fig. 10.7 Forward shower sump pump. the pump locates behind forward macerator.

10.2.5 Macerator Pump

The macerator pump disposes of black water discharge

or raw sewage. This will be any material from the holding tank.

Your toilet pumps the material to your holding tank, then when you are in legal waters to dispose of the materials, you can remove the materials from your holding tank with the macerator pump. Refer to the Operations and Maintenance subject in this section to learn how to operate the macerator safely.



Fig. 10.8 image of macerator

The macerator pump acts as a garbage disposal in your home. The pump contains “chopping wheels” that chop and grind the solid waste into pieces small enough to pass through the discharge hoses and the overboard discharge valve.

Important: U.S. Coast Guard regulations require that boats have a sanitation system on board to control pollution. Waste is to be stored in a holding tank or other device so it can be properly disposed of at a shore facility. Discharging this waste overboard in U.S. lakes, rivers, bays, and sounds and within 3 miles of shore in international waters is prohibited. Check with the Coast Guard regarding regulations in your area.

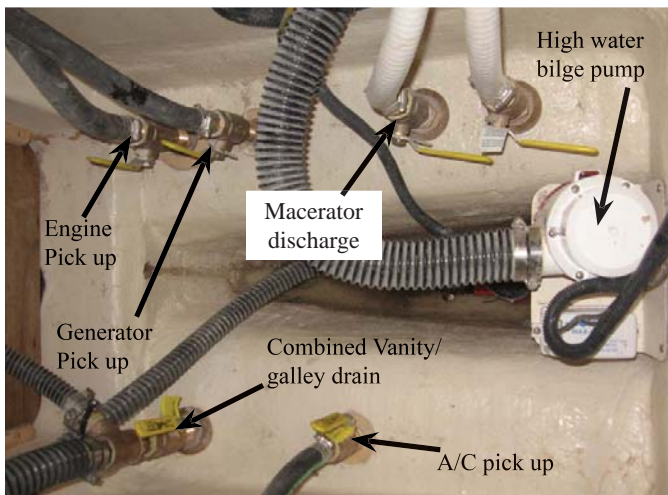

Fig. 10.9 shows the function of thru hull for different equipments onboard. They locate in the main bilge compartment

Refer to the mechanical arrangement illustration in the

Boating Safety section or the Sanitation arrangement at the end of this section for location information for the macerator pump.

10.3 Other Waste Related Equipment

10.3.1 Engine / Generator Exhaust

The subject here will be discussed in the Engine & Transmission Section. The motivation for placing this subject in the Sanitation System Section is due to the fact that exhaust is discharged from your boat. We will have an entire subject concerning engine and generator exhaust in the Engines and Transmissions Section. Here we will simply mention that the exhaust is a gas, Carbon Monoxide and is very dangerous. Be sure to follow all guidelines concerning Carbon Monoxide.

10.3.2 Holding Tank

The holding tank on your boat is installed to hold black water waste until you can safely dispose or pump it overboard. Refer to the Arrangement Illustrations in the Boating Safety section or at the end of this section for location information about the holding tank. Refer to the Operations and Maintenance subject of this section to learn how to perform maintenance on your holding tank, or to learn how to pump it out.

Remember: You must make sure it is legal to empty your holding tank in the waters you occupy. Some areas have restrictions on pumping out black water waste!

10.4 Head System

All vessels with fixed toilets that are operated on the waterways of the United States and some foreign countries are required to be equipped with an operable Marine Sanitation Device (MSD). The Marine Sanitation System aboard your boat is a waste tank system defined by the United States Coast Guard as a Type III System. Type III systems permit operation of the toilet without direct discharge of untreated waste after every flush. Type III systems can be discharged at a Marina, Dockside Pump-out stations or, if in coastal waters, at least three miles offshore.

Note: Overboard discharge capabilities must remain inoperative while within the 3 mile limit. This is accomplished by closing the macerator discharge through hull valve. Refer to the Mechanical Arrangement illustration in the Boating Safety Section or the Sanitation Arrangement illustration at the end of this section.

10.4.1 Electric Head System

These heads are typically designed to use raw water. There is a discharge. Between the toilet and the waste tank is a device called a macerator that is not totally unlike a blender or a garbage disposal in that it purees solid waste and paper. Macerating heads require more flush water than any other type of toilet, a minimum of 1 gallon to rinse urine completely out of the machinery, a minimum of 3 gallons of clear solids and paper. Insufficient flushing shortens the life of the motor and macerator.

The 12 volt electric marine toilet comes with a compact white vitreous china bowl and is equipped with a dual function pump which eliminates having to mess with hand pumps and dry bowl valves. With the simple push of a single switch, the self-priming flush pump rinses the bowl.

The toilet is controlled by a switch at the MDP. Refer to the electrical sections of this manual for more information about MDP. Refer to the location illustrations in this section or the Boating Safety section for location information of your sanitation system.

In Fig. 10.5, you will find a general outline illustration for the Electric Head systems. This illustrations will give you an idea about the components in the system and the routing of the waste lines.

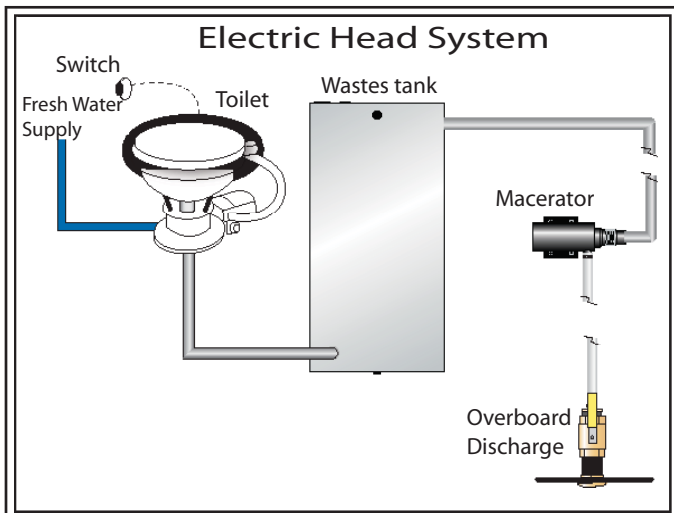

Fig. 10.10



Do not use chlorine-based or caustic cleaning agents, or chemicals such as a drain opening prod-

uct in your head systems. Use of these products may cause serious damage to the system's seals and hoses.

10.5 Operations and Maintenance

This section details the system's operation and maintenance on the components or systems if applicable.

10.5.1 Bilge Pumps

As we previously discussed in this section and in the DC Electric Systems Section, your boat has a total of four (4) bilge pumps. The Emergency, or High Water Pump, and the fwd, mid, and aft bilge pumps. We detailed the operations of these pumps in the DC Electric Section (Section 7).

Here are the steps mentioned in that subject:

10.5.1.1 To manually operate your bilge pumps:

Note: The power to the MDP does not need to be energized in order to manually operate your bilge pumps.

1. Locate the bilge pump switches at the MDP and switch them to the manual position.
2. Another procedure to be used in extreme circumstances involves locating the float switch and manually rotating the float handle on the side of the float switch to simulate the float switch being underwater. This will energize the pump and the pump will operate.

10.5.1.2 Maintenance on bilge pumps

No maintenance is required other than ensuring that the float switches are operational and that there is no debris clogging the pump intakes.



Running the macerator when the holding tank is empty will cause damage to the pump.

10.5.2 Macerator Operation

1. Open the macerator discharge valve (The discharge valve locates in main bilge discharge compartment by inboard side of galley).
2. Switch the "MACERATOR" breaker on at the DC

Panel. (The toggle switch locates by chart table)

3. Allow the macerator to run until the holding tank is empty, but no longer.
4. When you hear the pump speed up, indicating the holding tank is empty, immediately switch the pump off.
5. Close the overboard discharge valve.



Failure to close the overboard discharge valve when not in use could cause the holding tank to fill and possibly flood the boat.



Waste in the holding tank can form methane gas. Use suitable precautions when any maintenance is done to the sanitary system.

Note: The macerator pump unit has been designed to handle waste, toilet tissue, and facial tissue. It will not pump solid objects like fruit pits, rags, wet strength kitchen towels, tampons or sanitary napkins. Make sure the battery is fully charged. The dc motor is suitable only for intermittent duty and should not be run for more than 15 minutes continuously (Please refer to the equipment owner’s manual for more details)

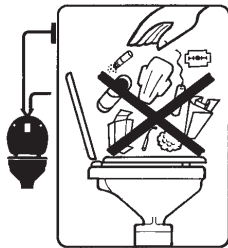

Fig. 10.11 Do not pump solid objects like fruit pits, rags, wet strength kitchen towels, tampons or sanitary napkins that will damage the macerator.

Helpful Hint: Should the macerator pump become clogged, you can manually rotate the internal grinder wheels by removing the small plastic cap on the back of the macerator pump. This encloses the screw which is attached to the grinding wheels and by inserting a flat screwdriver, you can rotate the wheels and possibly remove any debris clogging the pump.

10.5.3 Shower Sump

The shower sump is controlled by a rocker switch on the vanity face.

10.5.3.1 Maintenance Instruction

Drain the unit during the winter months when not in use. Disconnect and drain all lines to the unit. Remove hold-down clamps and empty the unit. For improved performance, periodically clean the filter. Remove the cover and slip the filter out for easy cleaning. Re-install the filter and cover when finished. (For more instructions about on the maintenance of this item, please refer to Original Equipment owner’s manual)

10.5.4 Holding Tank

The holding tank must be cleaned or pumped out when it becomes nearly full. There are two methods for removing waste from the holding tank, either by pumping overboard in coastal waters, or by dockside pump-out at a waste facility.

10.5.4.1 Overboard Pump-out Operation

See the macerator operation guide for pump-put the waste holding tank. Ensure the through hull ball valve is open before the macerator is activated. Close the ball valve when waste holding tank is empty.

Important: U.S. Coast Guard regulations require that boats have a sanitation system on board to control pollution. Waste is to be stored in a holding tank or other device so it can be properly disposed of at a shore facility. Discharging this waste overboard in U.S. lakes, rivers, bays, and sounds and within 3 miles of shore in international waters is prohibited. Check with the Coast Guard regarding regulations in your area.

10.5.4.2 Dockside Waste Removal

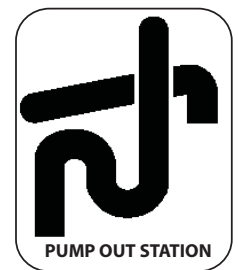

Fig. 10.12 shows waste holding tank pump out fitting. Only pump out sanitation material at pump out station where is available

To remove waste from the holding tank at a dockside

waste facility, insert the hose from the pump-out facility into the waste access on the coaming of your boat and follow instructions at the facility. Instructions from one facility to another may vary.

Fig. 10.12

10.5.4.3 Maintenance

Maintenance on the holding tank is best described as ensuring no methane gas is leaked and to keep odors down to a minimum. Any deodorizer may be used as long as it contains no alcohols or strong chemicals. Steer clear of drain opening type chemicals or strong bleaching type agents.

10.5.5 Toilet Operation

Ensure that the raw water system is operational.

Instructions for operating the electric head are mounted at the toilet. Follow these carefully.

10.5.5.1 Toilet Maintenance

Clean with mild cleaners and consult your owner’s packet for further instructions.

Save Our Seas !

It is illegal to dump plastic trash anywhere into the ocean or navigatable waters of the United States. Violation of these requirements may result in civil penalty up to \$25,000, a fine of \$50,000 and imprisonment for up to five years.

<p>PLASTIC - limited to : plastic bags styrofoam cups and lids, sixpack holders, stirrers, synthetic fishing nets, ropes, lines, and bio or photo degradable plastics. Includes but is not</p>	<p>GARBAGE - Means paper, rags, glass, metal, crockery (generated in living spaces aboard the vessel-what we normally call trash), and all kinds of food, maintenance and cargo-associated waste "Garbage" does not include fresh fish or fish parts, dishwater and gray water.</p>	<p>DUNNAGE- Material used to block and brace cargo, and is considered a cargo associated waste.</p> <p>GRAYWATER- Means drainage from a dishwasher, shower, laundry, bath, and washbasin, and does not include drainage from toilets, urinals, hospitals, and cargo spaces.</p>	<p>DISHWATER- Means the liquid residue from the manual or automatic washing of dishes and cooking utensils which have been pre-cleaned to the extent that any food particles adhering to them would normally interfere with the operation of automatic dishwashers.</p>
---	--	---	--

INSIDE 3 MILES	3 TO 12 MILES	12 TO 25 MILES	12 TO 25 MILES
(and in U.S. Rivers, Bays and Sounds) PLASTICS DUNNAGE, LINING AND PACKING MATERIALS THAT FLOAT ANY GARBAGE EXCEPT DISHWATER GRAYWATER, FRESH FISH PARTS	PLASTICS DUNNAGE, LINING AND PACKING MATERIALS THAT FLOAT ANY GARBAGE NOT GREATER THAN ONE SQUARE INCH	PLASTICS DUNNAGE, LINING AND PACKING MATERIALS THAT FLOAT	PLASTICS

Hunter 50cc • Waste and Sanitation Systems

Troubleshooting		
Problem	Cause	Solution
Head Not Flushing	Head breaker Off Battery Charge Low	Switch Breaker to on. If Breaker is tripped determine cause and correct. Charge Batteries
Head Not Emptying	Blocked line to tank	Remove material from line
Shower Sump Overflowing	Head Breaker OFF Discharge line blocked Pinched Line Defective Float Switch Defective Pump	Switch Breaker to on. If Breaker is tripped determine cause and correct. Clear material from line Straighten line Replace Switch (See your dealer for service) Replace Pump (See your dealer for service)

50CC WASTE WATER SYSTEM (BLACK WATER)

Save Our Seas!

It is illegal to dump plastic trash anywhere into the ocean or navigable waters of the United States. Violation of these requirements may result in civil penalty up to \$25,000, a fine of \$50,000 and imprisonment for up to five years.

PLASTIC: - limited to : plastic bags (generated in living spaces styrofoam cups and holders, stirrers, normally call trash), and all synthetic fishing nets, ropes, kinds of food, maintenance lines, and bio or photo degraded- "Garbage" does not include fresh fish or fish parts, dishwater and gray water.

DUNNAGE: Material used to block and brace cargo, and is considered a cargo associated waste.

GRAYWATER: Means drain water from a dishwasher, shower, laundry, bath, and washbasin, and does not include drainage from toilets, urinals, hospitals, and cargo matic dishwashers.

GARBAGE: - Means paper, rags, glass, metal, crockery (generated in living spaces), lids, aboard the vessel, what we normally call trash), and all kinds of food, maintenance and cargo-associated waste. "Garbage" does not include fresh fish or fish parts, dishwater and gray water.

DISHWATER: Means the liquid residue from the manual or automatic washing of dishes and cooking utensils which have been pre-cleaned to the extent that any food particles adhering to them would normally interfere with the operation of auto matic dishwashers.

INSIDE 3 MILES 3 TO 12 MILES 12 TO 25 MILES 12 TO 25 MILES

PLASTICS

PLASTICS
DUNNAGE, LINING AND PACKING MATERIALS THAT FLOAT

(and in U.S. Rivers, Bays and Sounds)
PLASTICS
DUNNAGE, LINING AND PACKING MATERIALS THAT FLOAT

PLASTICS
DUNNAGE, LINING AND PACKING MATERIALS THAT FLOAT
ANY GARBAGE NOT GROUND TO LESS THAN ONE SQUARE INCH
GRAYWATER, FRESH PARTS

- 9. WASTE TANK
- 10. WASTE TANK VENT FITTING (Ø5/8")
- 11. WASTE INLET FITTING
- 12. BALL VALVE (Ø5/8")
- 13. WASTE TANK VENT THRU HULL FITTING (Ø5/8")
- 14. MACERATOR PLATFORM
- 15. WASTE TANK MAINTENANCE PORT
- 16. WASTE TANK PUMP OUT FITTING

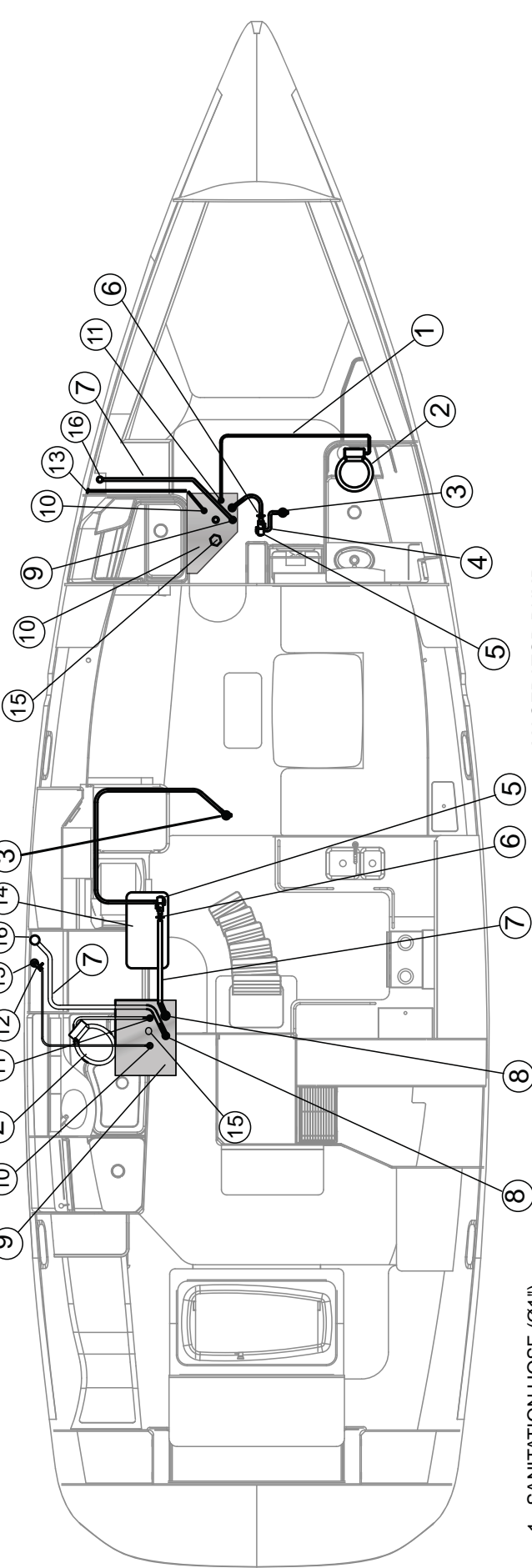

- 1. SANITATION HOSE (Ø1")
- 2. QUIET FLUSH TOILET
- 3. MACERATOR DISCHARGE THRU HULL FITTING WITH BALL VALVE (Ø1")
- 4. MACERATOR DISCHARGE HOSE (Ø1")
- 5. MACERATOR PUMP
- 6. MACERATOR BALL VALVE (Ø11/2")
- 7. WASTE TANK PUMP OUT HOSE (Ø11/2")
- 8. WASTE TANK PUMP OUT FITTING (Ø11/2")

50cc WASTE WATER SYSTEM (BLACK WATER)

- 9. WASTE TANK
- 10. WASTE TANK VENT FITTING (Ø5/8")
- 11. WASTE INLET FITTING (Ø1")
- 12. BALL VALVE (Ø5/8")
- 13. WASTE TANK VENT THRU HULL FITTING (Ø5/8")
- 14. MACERATOR PLATFORM
- 15. WASTE TANK MAINTENANCE PORT
- 16. Y VALVE
- 17. ANTI-SIPHON VALVE (Ø1")
- 18. OVERBOARD DISCHARGE THRU HULL FITTING (Ø1")

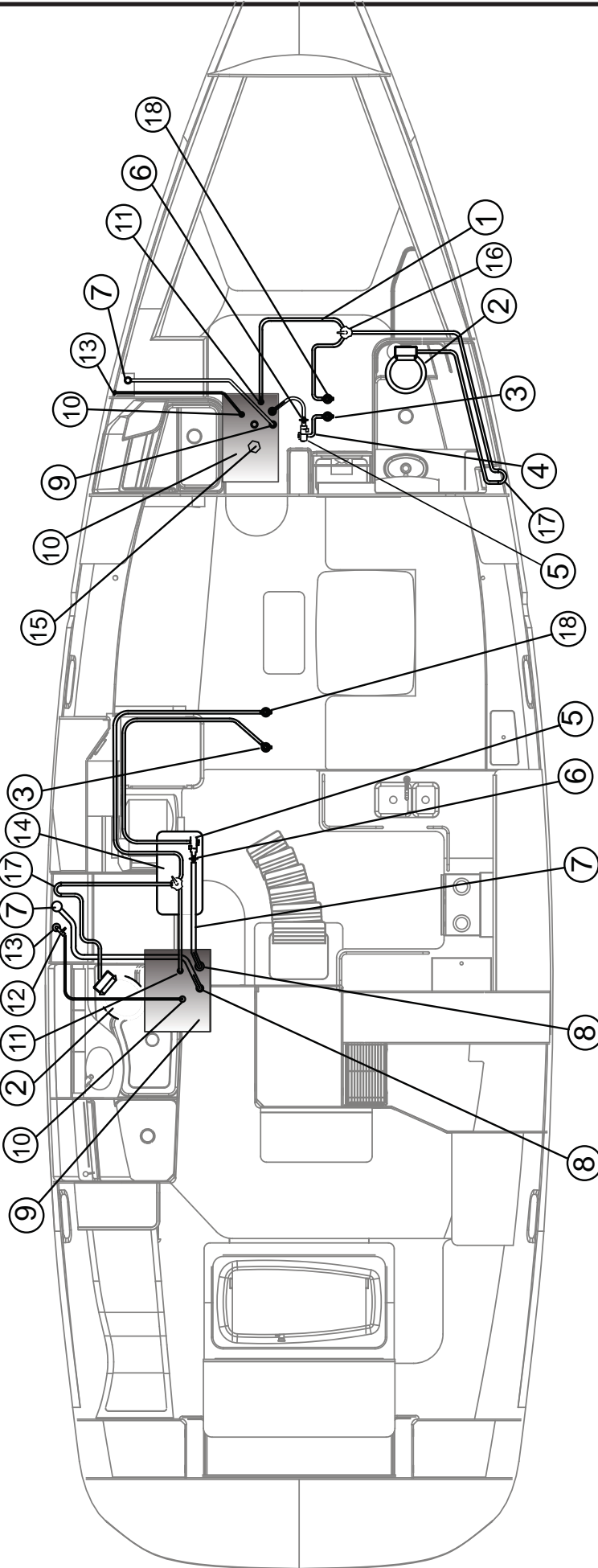

- 1. SANITATION HOSE (Ø1")
- 2. QUIET FLUSH TOILET
- 3. MACERATOR DISCHARGE THRU HULL FITTING WITH BALL VALVE (Ø1")
- 4. MACERATOR DISCHARGE HOSE (Ø1")
- 5. MACERATOR PUMP
- 6. MACERATOR BALL VALVE (Ø1 1/2")
- 7. WASTE TANK PUMP OUT HOSE (Ø1 1/2")
- 8. WASTE TANK PUMP OUT FITTING (Ø1 1/2")

Save Our Seas!

It is illegal to dump plastic trash anywhere into the ocean or navigable waters of the United States. Violation of these requirements may result in a civil penalty up to \$25,000 and imprisonment for up to five years.

<p>PLASTIC - Means paper, bags, glass, metal, crockery (generated in living spaces limited to : plastic cups and lids aboard the vessel-what we normally call trash), and all synthetic fishing nets, ropes, lines, and bio or photo degradable plastics includes but is not limited to :</p>	<p>GARBAGE - Means paper, bags, glass, metal, crockery (generated in living spaces aboard the vessel-what we normally call trash), and all synthetic fishing nets, ropes, lines, and bio or photo degradable plastics includes but is not limited to :</p>	<p>DUNNAGE-Material used to block and brace cargo, and is considered a cargo associated waste.</p>	<p>DISHWATER-Means the liquid residue from the manual or automatic washing of dishes which have been used to the extent that any food particles adhering to them would normally interfere with the operation of automatic dishwashers.</p>
<p>INSIDE 3 MILES (In U.S. Rivers, Bays and Sounds)</p>	<p>3 TO 12 MILES</p>	<p>12 TO 25 MILES</p>	
<p>PLASTICS DUNNAGE, LINING AND PACKING MATERIALS THAT FLOAT ANY GARBAGE NOT GROUND TO LESS THAN ONE SQUARE INCH</p>	<p>PLASTICS DUNNAGE, LINING AND PACKING MATERIALS THAT FLOAT</p>	<p>PLASTICS DUNNAGE, LINING AND PACKING MATERIALS THAT FLOAT</p>	<p>PLASTICS</p>



50cc WASTE WATER SYSTEM (GRAY WATER)

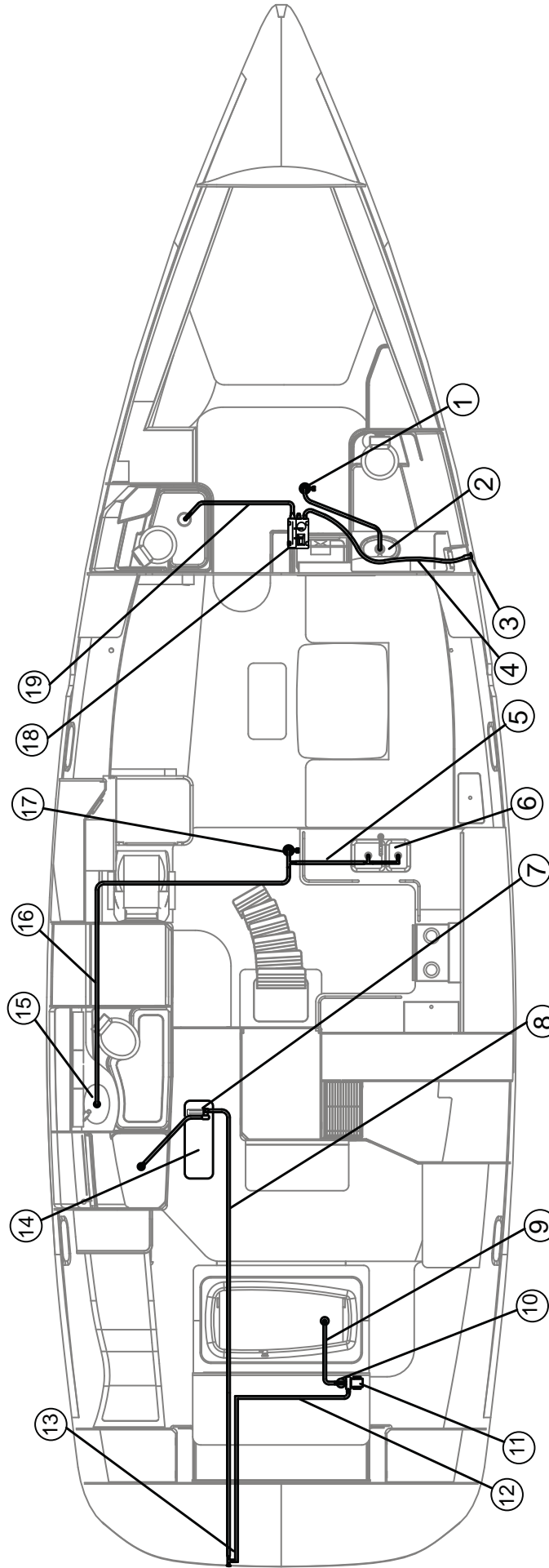

1. FWD VANITY THRU HULL FITTING WITH BALL VALVE (Ø 1")
2. FWD VANITY SINK
3. FWD SHOWER SUMP THRU HULL FITTING (Ø3/4")
4. FWD SUMP DISCHARGE HOSE (Ø 3/4")
5. GALLEY SINK DISCHARGE HOSE (Ø11/2")
6. GALLEY SINK
7. AFT SHOWER SUMP PUMP
8. AFT SHOWER SUMP DISCHARGE HOSE (Ø3/4")
9. AFT CABIN SOAKING TUB DRAIN HOSE (Ø1 1/2")
10. SOAKING TUB DRAIN FILTER
11. SOAKING TUB DISCHARGE PUMP
12. SOAKING TUB PUMP DISCHARGE HOSE (Ø3/4")
13. AFT VANITY / SOAKING TUB DISCHARGE THRU HULL FITTING
14. AFT SUMP PUMP PLATFORM
15. AFT VANITY SINK
16. AFT VANITY SINK DRAIN HOSE (Ø1")
17. GALLEY / AFT VANITY SINK DISCHARGE THRU HULL FITTING (Ø1")
18. FWD SHOWER SUMP PUMP
19. FWD SHOWER SUMP DISCHARGE HOSE (Ø11/8")

Save Our Seas !

It is illegal to dump plastic trash anywhere into the ocean or navigable waters of the United States. Violation of these requirements may result in civil penalty up to \$25,000, a fine of \$50,000 and imprisonment for up to five years.

PLASTIC - plastic bags, cups and lids, styrofoam holders, synthetic fishing nets, lines, and bio or photo degradable plastics. Includes but is not limited to:

DUNNAGE - Material used to block and brace cargo, and is considered a cargo associated waste.

GRAYWATER - Means drain water from a dishwasher, shower, laundry bath, and washbasin, and does not include drainage from toilets, urinals, hospitals, and cargo hold spaces.

GARBAGE - Means paper, rags, glass, metal, crockery (generated in living spaces aboard the vessel), and all kinds of food, maintenance and cargo-associated waste (fresh, fish, or fish parts, dishes, hospitals, and cargo hold spaces).

DISHWATER - Means the liquid residue from the manual or automatic washing of dishes and cooking utensils which have been pre-cleaned to the extent that any food particles adhering to them would normally interfere with the operation of auto malt dishwashers.

DUNNAGE LINING AND PACKING MATERIALS THAT FLOAT

DUNNAGE LINING AND PACKING MATERIALS THAT DO NOT FLOAT

ANY GARBAGE EXCEPT DISHWATER, GRAYWATER, FRESH/FISH PARTS

PLASTICS

INSIDE 3 MILES

3 TO 12 MILES

12 TO 25 MILES

25 TO 50 MILES

50 TO 100 MILES

100 TO 200 MILES

200 TO 500 MILES

500 TO 1000 MILES

1000 TO 2000 MILES

2000 TO 5000 MILES

5000 TO 10000 MILES

10000 TO 20000 MILES

20000 TO 50000 MILES

50000 TO 100000 MILES

100000 TO 200000 MILES

200000 TO 500000 MILES

500000 TO 1000000 MILES

1000000 TO 2000000 MILES



50cc BILGE WATER SYSTEM (GRAY WATER)

- 7. HIGH WATER BILGE THRU HULL FITTING (Ø2")
- 8. HIGH WATER BILGE HOSE (Ø2")
- 9. HIGH WATER BILGE PUMP FLOAT SWITCH
- 10. HIGH WATER BILGE PUMP
- 11. MANUAL BILGE HOSE (Ø1 1/2")
- 12. MANUAL BILGE PUMP (MOUNTED ON DECK)

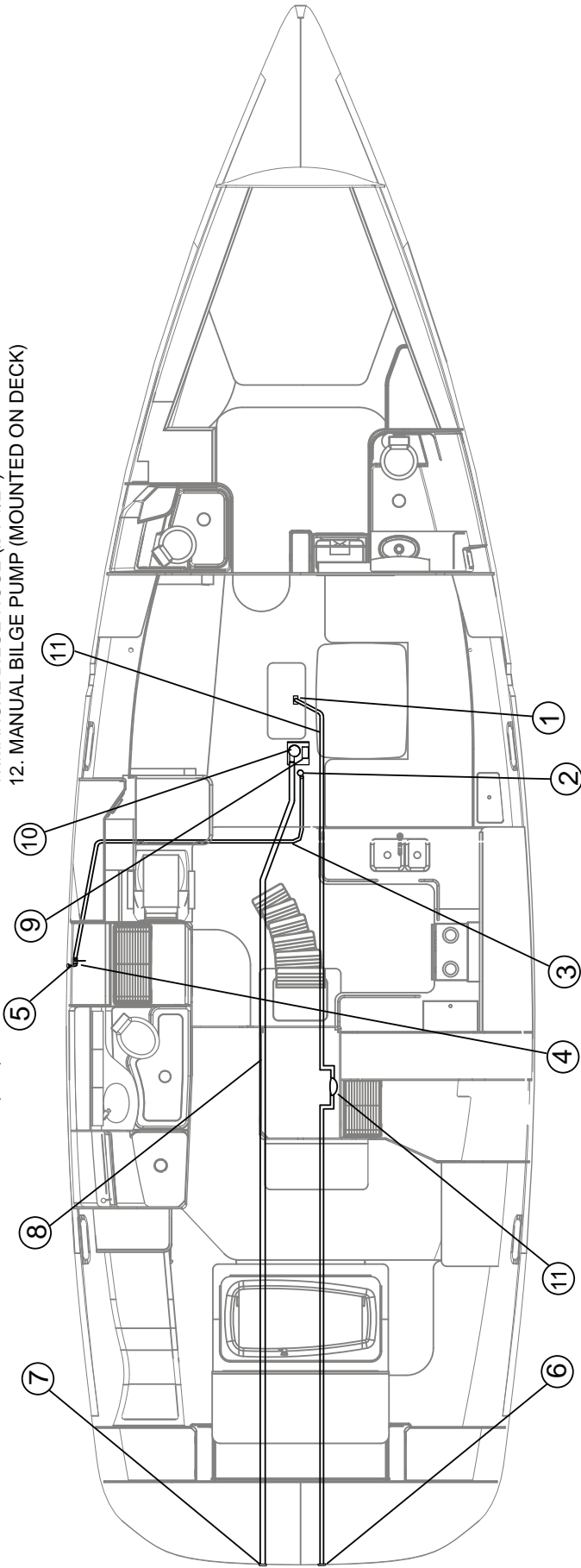

- 1. MANUAL BILGE STRAINER
- 2. ELECTRIC BILGE PUMP
- 3. ELECTRIC BILGE DISCHARGE HOSE (Ø1 1/8")
- 4. BALL VALVE (Ø1")
- 5. ELECTRIC BILGE DISCHARGE THRU HULL FITTING (Ø1 1/8")
- 6. MANUAL BILGE DISCHARGE THRU HULL FITTING (Ø1 1/2")

Save Our Seas!

It is illegal to dump plastic trash anywhere into the ocean or navigable waters of the United States. Violation of these requirements may result in civil penalty up to \$25,000, a fine of \$50,000 and imprisonment for up to five years.

PLASTIC - limited to : plastic bags (generated in living spaces), styrofoam cups and lids, aboard the vessel-what we normally call trash), and all synthetic fishing nets, ropes, and cargo-associated waste lines, and bio or photo degradable plastics. Includes but is not fresh fish or fish parts, dishwater and gray water.

DUNNAGE-Material used to block and brace cargo, and is considered a cargo associated waste.

GRAYWATER- Means drain age from a dishwasher, shower, laundry, bath, and washbasin, and does not include drainage from toilets, urinals, hospitals, and cargo matic dishwashers.

INSIDE 3 MILES

(and in U.S. Rivers, Bays and Sounds)

PLASTICS

DUNNAGE, LINING AND PACKING MATERIALS THAT FLOAT

ANY GARBAGE EXCEPT DISHWATER

GRAYWATER, FRESH FISH PARTS

3 TO 12 MILES

PLASTICS

DUNNAGE, LINING AND PACKING MATERIALS THAT FLOAT

ANY GARBAGE NOT GROUND TO LESS THAN ONE SQUARE INCH

GRAYWATER, FRESH FISH PARTS

12 TO 25 MILES

PLASTICS

DUNNAGE, LINING AND PACKING MATERIALS THAT FLOAT

ANY GARBAGE EXCEPT DISHWATER

GRAYWATER, FRESH FISH PARTS





H U N T E R[®]

MARINE CORPORATION

AN EMPLOYEE OWNERSHIP COMPANY

We Go The Distance

Chapter 11

***Engine
and
Transmissions
— Hunter 50cc —***



Hunter 50cc • Engines and Transmissions

The following is a list of components associated with your engines and transmissions.

- Engine
- Controls
- Engine Monitoring
- Engine Cooling
- Emergency Equipment
- Engine Exhaust
- Transmission (s)
- Shifters and Controls



Take proper care when washing down, or cleaning your engines, that water does not enter the air intakes. Water in the air intakes may go directly to the cylinders, resulting in rust and possibly internal engine damage.

11.1 Engines

The engine on your boat is at the heart of your boat. Proper attention to and maintenance of your engine will assure you many hours of pleasurable, safe boating, and will prevent unnecessary engine problems. You must, therefore, become thoroughly familiar with all aspects of the engines proper operation outlined in the manufacturers Operator's Manuals.

A general maintenance program consists of proper lubrication, cleaning of fuel filters, fuel lines, and air filters.



Fig. 11.1 shows you propulsion unit and components aboard your boat.

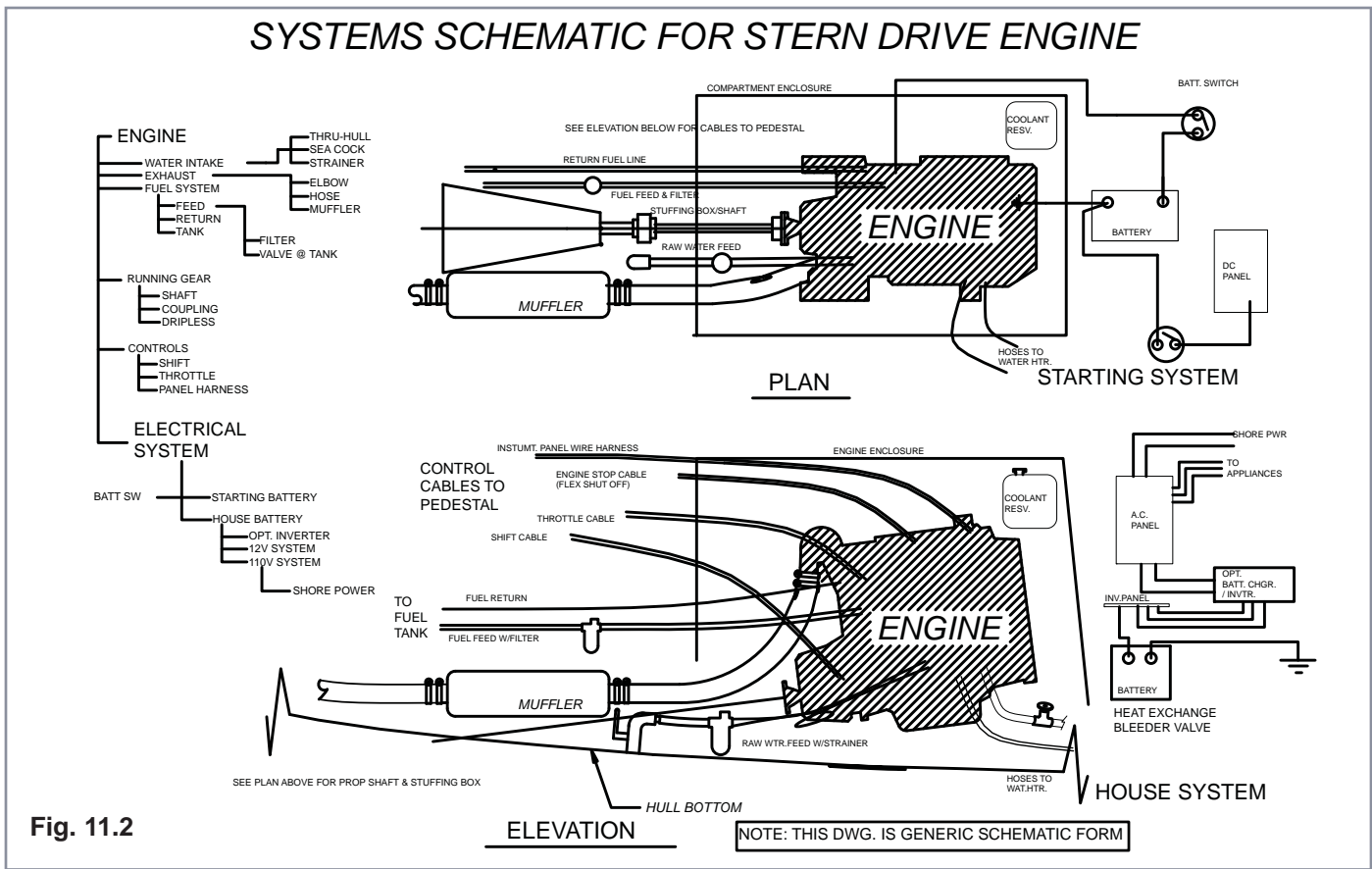

Fig. 11.2

We strongly urge you to comply with the manual provided by the engine manufacturer. Follow the recommended maintenance and warranty schedule in the owner's packet. Engine abuse or improper maintenance may adversely affect the claims made under the independent warranty provided by the engine manufacturer.

The engine manual states the maximum RPM rating established by the engine manufacturer for your boat's engines. Do not exceed this rating. Check the manual for other information about maximum RPM's.

Engines are selected and designed to meet or exceed industry standards set by marine engine manufacturers.

Important: Engines are not warranted by Hunter Corporation, these warranties are written by the engine manufacturers.



When occupying the engine room, or any area that mechanical equipment may be located, always be aware of moving parts or components. Death or dismemberment may be the result of being caught in moving machinery.

Important: Engines require air to operate. For this reason, do not operate the engine or generator with this area obstructed.

Important: The engine manual supplied by the manufacturer includes complete and detailed information about operating and maintaining your boat's engines. Be sure to read it. Do not start or operate the boat's engines until you have done so. The life and performance you receive from your engines depends greatly on the way you care for it.

11.1.1 Engine Mounts

The engine mounts supplied with your boat are manufactured by the engine manufacturer. These mounts are designed specifically for the engine in which they are attached.

Most engine mounts are designed for adjustment sideways as well as vertical. Vertical adjustment nuts lock up or down on the threaded vertical stud, with a slot provided to allow side to side adjustment on the engine.

Important: It is advisable to spray a protective coating on the studs to prevent corrosion.

Many factors warrant the size and type of engine mounts

that are used. These mounts also contain isolators which isolate the engine from the boat or stringers to dampen vibration, noise, and other undesirable effects from engines. For more information about the engine mounts see the engine manufacturers manuals.

11.1.2 Engine Controls

The engine controls on your boat are located on the steering pedestal.

The straight up position is neutral, shift forward to go forward, moving further forward increases the speed.

Move the lever backwards for reverse, the same as forward more movement in the reverse direction increases the engine speed.

Press and hold the center button on the shift lever, and move the lever forward to increase the engine RPM without shifting into gear.

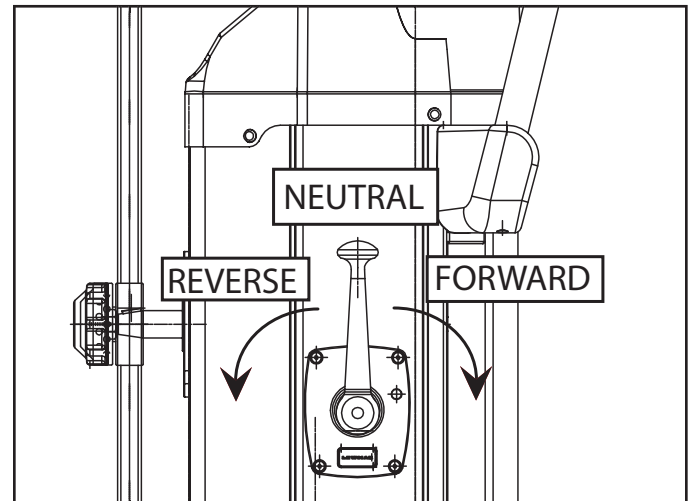

Fig.11.3 Engine throttle / transmission control

11.1.3 Engine Monitoring



Always monitor your boats oil pressure, and water temp. while underway, even if your engines are equipped with an alarm system to monitor these.

Shut down the engines immediately if the gauges are not in normal ranges or an alarm sounds. Do not restart your engines until the problem is

corrected.

For information on the correct levels for engine running, please consult your engine owner's manuals from the engine manufacturer in your owner's packet.

Important: The Hour meter will run if you leave the ignition switch on when the engine is not running. This unnecessarily increases the number of engine hours.

Note: Instruments have a tolerance for accuracy. In addition, each engine may operate at differing values at the same RPM. As long as the instruments are reading within the proper operating range, the engine is operating properly.

11.1.4 Engine Cooling

There are two separate systems that cool your engines. The raw water cooling system is described in detail in your "Water Systems" (section 9) of this manual. The internal engine cooling system is supplied by the engine manufacturer. This system features a closed antifreeze coolant bottled in a reservoir attached to the engine. Coolant is circulated through the engine in separate channels than the raw water cooling.

Note: Be sure the engine seacocks are open before you start the engine. Failure to open them will cause damage to the water pump impeller.



Hot coolant under pressure may boil over and cause burns or other personal injury when pressure cap is removed. Allow engine to cool. Open pressure cap slowly to allow pressure to vent before removing cap.

11.1.5 Emergency Equipment

Your engines are set up to operate under the toughest conditions. However, should the oil pressure become too low, or the engine overheat, alarms will sound at the helm. There are several conditions that will sound an alarm and save you from damaging your engines. Be sure and study your documentation supplied by the engine manufacturer to ensure you will know what the alarm means should one sound on your boat.

11.2 Transmissions

The transmission has a reduction gear which drives the propeller at a slower rotation speed than that of the

engine.

Consult your OEM manual for complete transmission information.

11.3 Operations and Maintenance

In the Underway Chapter, (Chapter 12) you will find instructions on starting your engines. Also detailed in the manufacturer's documentation supplied with your boat, you will find instructions on maintenance items that you may perform yourself. Should you have any questions regarding maintenance or operations not provided, be sure and consult your boat dealer.

Important: Shift the transmission only when the engine speed is at or below 1000 rpm. Shifting at higher engine speeds could severely damage the boat, the transmission, and the engine. Allow the transmission to remain in neutral for a few seconds before reversing the rotation of the propeller.

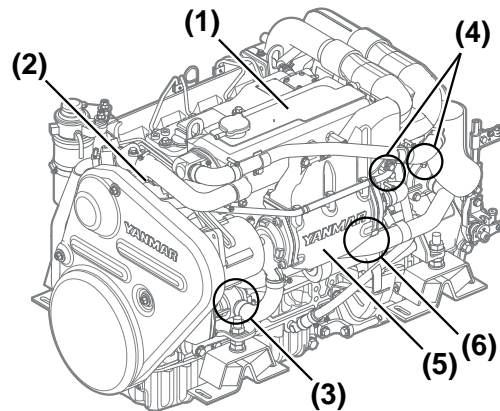

- 1 – Coolant Tank (Heat Exchanger)
- 2 – Coolant Pump (Fresh Water)
- 3 – Seawater Drain from Seawater Pump Cover
- 4 – Coolant Drain Cock
- 5 – Intercooler
- 6 – Seawater Drain from Seawater Pump Cover

Fig. 11.4

11.3.1 Hydrolock

Hydrolock is caused by water entering the engine cylinders through the exhaust. The following conditions can cause hydrolock.

Engine shutdown: A sudden engine shutdown while the boat is moving may force water into the exhaust system.

Anchored or adrift: Rough seas may cause rocking severe enough to cause water to splash out of the mufflers into the engine while the engines are shut down, anchored from the stern, pulling a sea anchor, or adrift.

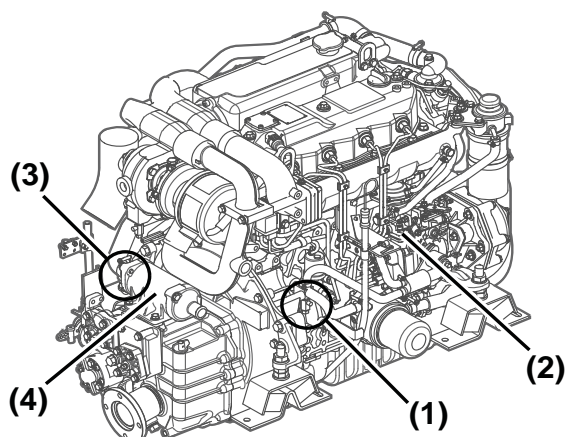

- 1 – Coolant Drain Cock
- 2 – Fuel Pump
- 3 – Seawater Drain Cock
- 4 – Marine Gear Cooler

Fig. 11.5

Improper hoisting: Operators are sometimes tempted to reduce hoisting time for propeller changes by hoisting only the boat stern. Such hoisting can cause residual water in the exhaust system to enter the engine cylinders.

! WARNING !

Engine manufacturers do not warranty items damaged by hydrolock.

11.3.2 Engine / Generator Exhaust

Your engine exhaust contains Carbon Monoxide! Be sure and read the Boating Safety Chapter and know the dangers and how to avoid them. Carbon Monoxide will kill you, and in most situations, by the time you know something is wrong it could be too late. Know what to look for and what to do in case of necessary action. Inspect your boat's exhaust system frequently, or have a qualified service technician service the system to ensure that there are no leaks.

Always ensure the exhaust clamps are tightened,, throughout the system.

Keep the necessary tools to perform this action on hand.

! DANGER !

Avoid the exhaust outlets, lines, hoses or equipment when the engines have been run for a period of time. These areas may be very hot! You can be seriously burned by the exhaust system after the engines have ran for a period of time. Allow the exhaust system to cool, before handling, or making adjustments to avoid injury.

Hunter 50cc • Engines and Transmissions

Troubleshooting		
Problem	Possible Cause	Solution
Engine not starting	<p>No fuel reaching engine</p> <p>Improper starting procedures</p> <p>Contaminated fuel</p>	<p>Fuel tank vent blocked. Clean hose and fitting to remove material. Make sure hose is not pinched</p> <p>Fuel line obstructed. Check fuel lines. Make sure line is not pinched</p> <p>Clogged engine fuel filter. Refer to engine manual for instructions on cleaning filter</p> <p>Fuel supply valve closed at tank. Open valve</p> <p>Review starting procedures in engine manual</p> <p>Inspect for water or other contaminants in fuel. If contaminated, drain tank and flush with fresh fuel</p>
Engine starter not cranking	<p>Discharged battery</p> <p>Corroded battery terminals</p> <p>Loose battery terminals</p> <p>Bad starter switch</p> <p>Hydrolock</p> <p>Jammed "starter drive."</p>	<p>Recharge or replace battery</p> <p>Clean battery terminals</p> <p>Tighten connections</p> <p>Test switch continuity. Replace switch if required. See your dealer for service</p> <p>Replace switch</p> <p>See instructions in this Section under "Hydro-Lock". See your dealer immediately</p> <p>Loosen starter motor, then free stuck gear</p>
Engine speed erratic	<p>Pinched or clogged fuel lines</p> <p>Contaminated fuel</p>	<p>Replace line or remove obstruction</p> <p>See your dealer for service</p> <p>Drain fuel tank and lines. Flush with clean fuel and replace fuel filters.</p> <p>See your dealer for service</p>
Engine running rough	<p>Defective fuel pump</p> <p>Idle speed too low</p> <p>Faulty ignition system components</p> <p>Clogged fuel filter</p> <p>Pinched fuel lines</p> <p>Clogged fuel lines</p> <p>Blocked fuel vent</p>	<p>Have your dealer check pump</p> <p>Check idle speed and adjust as needed</p> <p>See your dealer for service</p> <p>Clean or replace filter</p> <p>Straighten lines</p> <p>Remove obstruction</p> <p>Clean vent</p>
Engine overheating	<p>Cooling water seacock closed</p> <p>Seacock pickup blocked</p> <p>Collapsed water pump suction hose</p>	<p>Open seacock</p> <p>Remove obstruction</p> <p>Replace hose</p>
Sudden increase in	Cooling water intake system blocked	Clean seacock strainer
Engine temperature	Water intake hose leaking or ruptured	Remove material blocking line
	Water pump failure	See your dealer for service

Hunter 50cc • Engines and Transmissions

Drop in oil pressure (engine running at constant speed)	Lubrication system leaking Defective oil pump Pinched oil lines to remote filters	Repair if possible. See your dealer for service See your dealer for service Reroute if possible. See your dealer for service
Excessive vibration	Loose engine mounting bolts Engine not timed properly or misfiring Engine-to-shaft couplings out-of-round or off-center Engine misaligned Worn strut or transmission	Inspect and tighten as required See your dealer for service See your dealer for service See your dealer for service Replace bearings if needed. See your dealer for service
Poor performance	Boat overloaded Weight poorly distributed Excess bilge water Damaged or incorrect propeller Fouled or damaged hull bottom Engine misaligned	Reduce load Distribute weight evenly. Trimming may help Pump out water. Check for leaks Inspect propeller. Replace if necessary Inspect, clean, or repair See your dealer
Low cranking speed	Loose or dirty electrical connections Low battery charge Defective battery Engine oil too heavy for prevailing temperatures	Check all related electrical connections and wires Charge battery Replace battery Drain oil and refill with correct grade viscosity oil. See engine manual for correct grade and viscosity
Poor acceleration	Throttle not full open Engine overheating	Inspect cables and linkage for binding, obstructions, and loose fasteners See solutions under "Engine Overheating" problem
Excessive fuel consumption	Restriction in air filter	Remove filter and clean or replace
Low oil pressure	Insufficient oil in crankcase Excess oil in crankcase Diluted or improper grade and viscosity oil Oil leak in pressure line	Check and add correct grade and viscosity oil. Visually check engine for leaks Check and remove required amount of oil. Check for cause of excessive oil (improper filling, bad fuel pump, etc.). Change oil and oil filter. Be sure to use the correct grade and viscosity oil Inspect all oil lines and tighten all connections as necessary
No oil pressure	Defective gauge, gauge tube, or oil line No oil in engine	Replace gauge or gauge sender Refill crankcase. See engine manual for proper grade and viscosity

Hunter 50cc • Engines and Transmissions

High oil pressure	Too heavy grade of oil Dirt or obstruction in oil line	Drain oil and replace. See engine manual for proper grade Drain and clear oil system. Check for bent or flattened oil lines and replace as necessary
Sludge in oil	Infrequent oil changes Dirty oil filter Water in oil	Drain oil and refill with oil of proper grade and viscosity Replace filter Drain oil and refill. See your dealer if problem persists
Transmission shifts hard	Corroded or pinched linkage	Lubricate or replace linkage as needed

50cc ENGINE EXHAUST SYSTEM

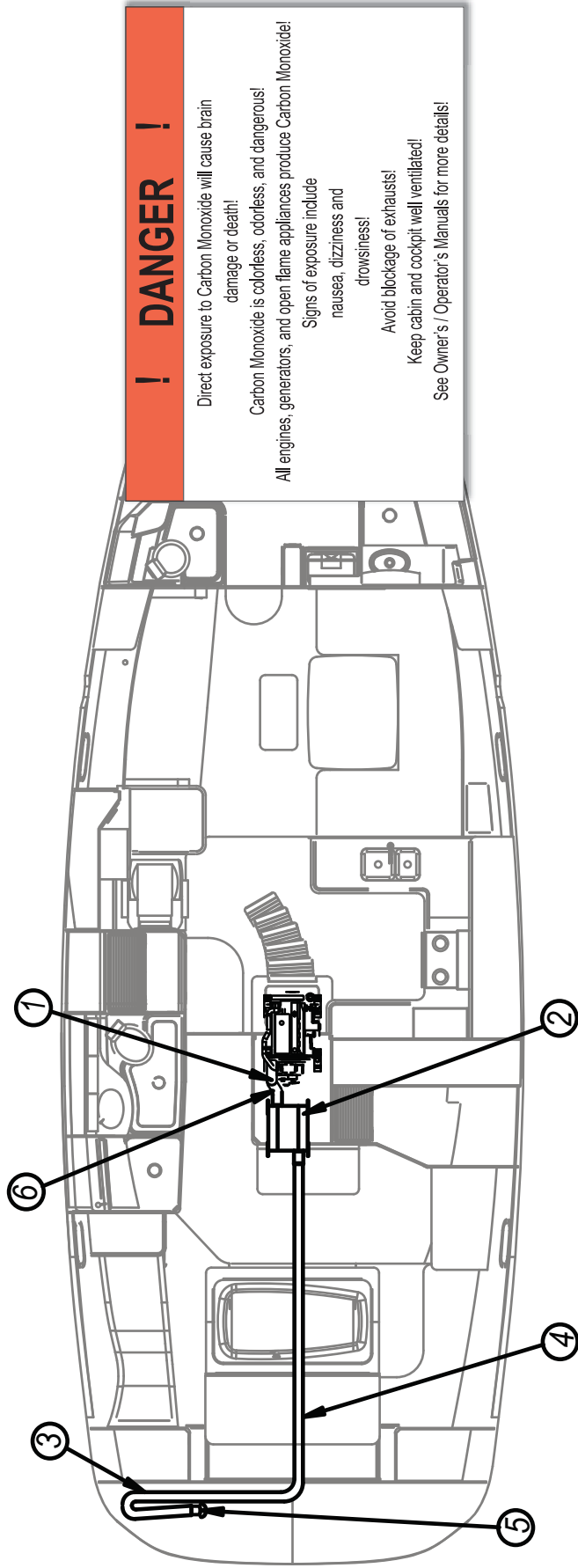

- 1. ENGINE EXHAUST U MIXING BOWL
- 2. WET EXHAUST SILENCER
- 3. EXHAUST VENTED LOOP
- 4. ENGINE EXHAUST HOSE (Ø3 1/2")
- 5. EXHAUST PORT (Ø3 1/2")
- 6. EXHAUST HOSE (Ø3")

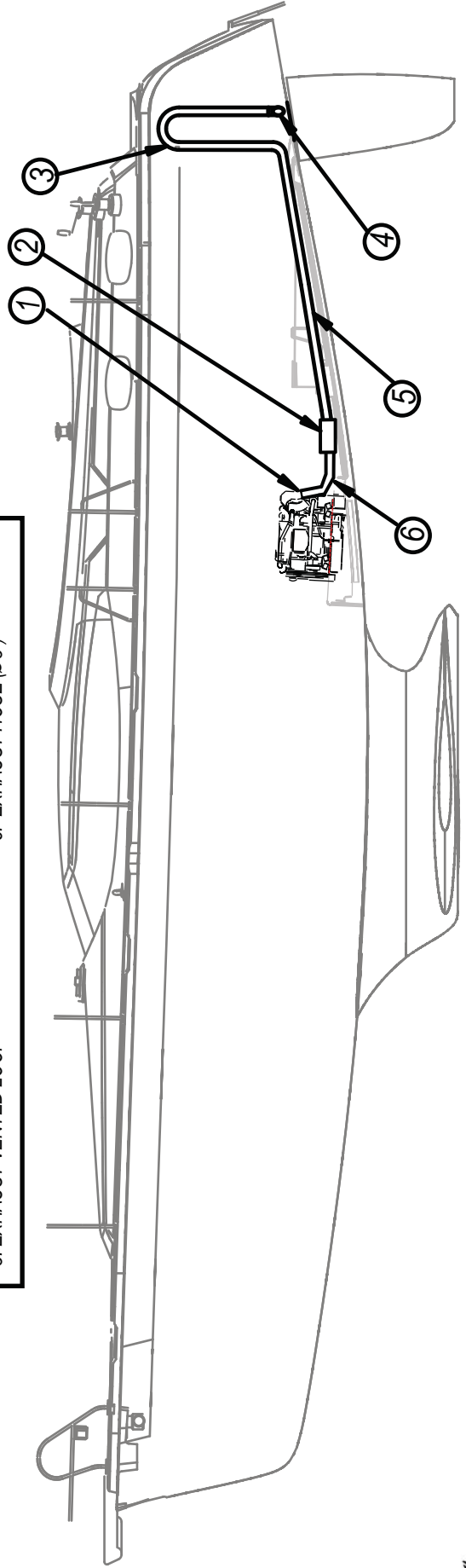



H U N T E R[®]

MARINE CORPORATION

AN EMPLOYEE OWNERSHIP COMPANY

We Go The Distance

Chapter 12

***Sails
and
Rigging***

Hunter 50cc



Sails & Rigging

Most sailors believe that sailing is hard work: all those lines to tend, halyards to yank and sails to lug. Hunter Marine has dispelled that myth once and for all! Innovations by the crew at Hunter Marine have made sailing easier, safer and more comfortable. The result - much more sailing fun!

Whether you are ready to set sail for the islands or just around the buoys, your Hunter can really make a difference. Starting with the tall, fractional rig, which is a direct descendent of the B&R rig, Hunter has engineered the mast to carry less weight aloft with a smaller sections. This is accomplished by utilizing swept-back spreaders and reverse diagonals. This combination provides superior strength without a backstay and increases the stability at the same time. By using a large roach main as the power sail, Hunter has eased the effort in sail handling and allowed for real versatility for all wind and sea conditions.

Your benefit: better performance with less effort. The deck layout reflects the innovation that accompanies the rig. An integrated arch protects the cockpit from snapping main sheets and blistering sun with the optional bimini. This arch keeps the cockpit clear and open.



WARNING



Refer to Boating Safety, and the Getting Underway chapters for safe boat handling information.

If this is your first boat of this type or you are changing to a new boat you are not familiar with, please ensure that you obtain handling and operating experience before assuming command of the boat. This document is not a course on boating safety or seamanship. Your dealer or national sailing federation or yacht club will be pleased to advise you of local sea schools, or competent instructors.

Never underestimate the potentially dangerous power of wind, tide and the sea. Always ensure there is sufficient trained and proficient crew on board to handle the boat and its operating systems even in adverse conditions.

NOTE: Standing rigging will stretch slightly when initially loaded. Therefore, the rigging may have to be further tensioned slightly after a few sails in a strong breeze to compensate for this initial stretch. Once the mast is tuned and initial stretch is taken out, the rig should need retuning only at the beginning of each season.

12.1 Main Rig Components

- Anodized B&R Rig Mast
- Boom
- Dual Single Line Reefing System (standard mast only)
- Self tacking / or overlapping Jib System
- Inboard Jib Track w / Adjustable Cars (option)
- Internal Halyards led to Cockpit
- Jib Furling System
- Large Roach Mainsail w/Flaking System (standard mast)
- Mainsheet on Arch
- Self-Tailing Jib Winches w/Handles
- Self-Tailing Rigging Winches w/Handles
- Line Stoppers & Organizers

Over the course of the next few pages we will outline some of the components featured here, along with some of the optional components of your sails and rigging aboard your Hunter sailboat.

12.2 The Mast

Your main and most vital rig component is the mast. It carries the sails and is supported by the standing rigging

Your Hunter features the B&R rig; a design by Lars Bergstrom and Sven Ridder. The design was born in the 70's and has been used on ocean racers as well as world cruisers producing tremendous success. The B&R rig is designed to eliminate babystay, backstays, and running backstays. The 30-degree sweptback spreaders and reverse diagonals support the mast sideways, fore, and aft and the shrouds are discontinuous. Weight is minimized and using a smaller mast section maximizes airflow to the main. The angles between the shrouds and forestay equal an even 120-degree triangle that evenly spreads the load of the mast. The information in the following describes the basic functions of each standing rigging :

Cap shrouds: (V1-V3, D4) Stay the mast against lateral (athwartship) loads. Attached near the masthead on a masthead rig, and at forestay level on a fractional rig. The cap shrouds are led via spreaders to the boat's chain plates.

Intermediate shrouds: (D2-D3) Fitted on multiplespreader rigs, and attached in the area of the upper spreaders. Fitted with links in the lower spreader tips

(linked rig). The intermediate shrouds stay the upper spreader area against movement athwartships.

Lower shrouds: Attached in the area of the lower spreaders. Stay the spreader-area athwartships. Often fitted as (D1), which also determining mast-bend.

Forestay: Sail-carrying stay for the genoa and jib. Prevents the top of the mast moving aft.

12.2.1 Running Rigging:

Running rigging arrangement used for raising, lowering and controlling the sails has been designed for your convenience. It's easy to recognize on the halyards, sheetings. With double stack triple deck organizer used gives you easier way to operate you boat. See more details information on running rigging arrangement illustrations in the following pages.



Fig. 12.1 shows the front view of mast with running rigging installed on the 50c.c

12.3 The Boom

The boom carries the lower sheeting point of your main sail and is controlled by the main sheet, the vang and the optional traveler lines. the illustration in the following pages demonstrating the boom with reefing layout and the Mainsheet Purchase layout.

Follow the equipment manufacturer's manual for instructions on boom installation.



Fig. 12.2

12.4 The Sails

The mainsail is the sail attached to the aft track of the mast and hoisted with the main halyard from the cockpit. The jib sail is attached to the forestay and like the mainsail hoisted with the jib halyard from the cockpit.

Most Hunter sailboats feature the control of the most important sail controls from the cockpit. In addition to the main and jib halyard you will find a main sheet line with a winch at the aft edge of the cockpit together with the vang and or outhaul control (some optional). The jib is controlled with the jib sheet control lines lead back to the cockpit coming either side. In addition the jib furling line located to the starboard side of the cockpit allows the safe and easy unfurling and furling in of the jib sail as well as optional port side overlapping jib furling system.

12.5 Reefing Instructions

Reefing procedure on the furling mast:

1. Carefully slacken off the outhaul line.
2. Whilst continuing to ease the outhaul, roll in the desired amount of sail, meanwhile, The leech should be kept fairly taut. Keep slight tension on the outhaul line while doing this.
3. Activate the lock on the reefing winch (IN) before reefing the sail.
4. As soon as the desired amount of sail is rolled in, use the outhaul to stretch the foot of the sail

See equipment manufacturer's manual for detail information on reefing procedures.

Note: Never leave the reefing winch handle in the winch!

It will rotate very rapidly when the sail is unfurled.

Reefing procedure on the standard mast:

1. Run both reefing lines as illustrated in the boom & reef layout. The shorter reef line will be used on the first reef (Starboard Side, Green). The longer reef line on the second reef (Port Side, Red).
2. Lower the main sail.
3. Ease the mainsheet and vang.
4. Lower the main sail to approximately the first reef position.
5. Take up the slack in the first reef line until the tack and the clew are down to about 2" above the boom.
6. Adjust the main halyard so that the tack reef point is not contacting the goose neck on the front of the boom and is applying tension to the luff of the main above the reef, not below. There will be approximately 6" (150mm) of stretch in the main luff and main halyard when the reefing line is tensioned, so, make sure that this is allowed for when adjusting the main halyard to locate the tack reef block.
7. Confirm that the tack reef point is still clear of the tack shackle and that only the main luff above the reef cringle is tensioned, not the luff between the cringle and the top stacked sail slide. Ease the reef line and readjust the halyard if necessary.
8. Mark the halyard at the stopper with 1" (25mm) single band of indelible marker ink. By dropping the halyard to this mark every time, positioning is made easier. The halyard is automatically in the correct position for the reef.
9. Repeat the procedure for the second reef, using double bands to mark the halyard in the correct position.

12.6 Reefing Procedure (During Sailing)

1. Head up into the wind.
2. Ease the mainsheet and vang.
3. Check the topping lift for adequate boom support.
4. Lower the main halyard to the appropriate mark and snub the line with the stopper.
5. Tension the reefing line with the self-tailing winch until

the reef clew is brought down to the boom. Apply stopper and tension the main halyard back up, ease the topping lift (if needed).

12.7 Shaking Out a Reef

1. Head up into the wind.
2. Ease the mainsheet and vang. Release the tension on the topping. Lift (if needed).
3. Release the line stopper and remove reef line from winch.
4. Tension the main halyard to raise sail, making sure reef lines run freely while sail is being raised. Apply stopper to main halyard.
5. Re-tension vang and mainsheet, ease the topping lift (if needed).

12.8 Spinnaker (Optional)

To set the optional spinnaker using the dedicated halyard, first attach the halyard to the head ring on the sail. Next, tie the tack downhaul line to the tack ring, lead it through a turning block on the deck near the bow or through the block on anchor roller, and run it aft to the cockpit. Set up the tack downhaul so the tack of the sail is about five inches above the deck when the sail is hoisted. Attach the spinnaker sheet to the clew ring of the spinnaker and make sure the line is led aft outside the lifelines to a turning block on the toe-rail located just forward of the stern pulpit. Then run it forward to a winch allowing total slack in the sheet. The sheet that is not being used — the lazy sheet — should also be attached to the clew of the spinnaker, led forward *in front of the headstay*, and then back on the other side of the boat — outside the shrouds and lifelines — to another turning block positioned just forward of the stern pulpit. Then take that sheet and lead it to a winch, with the slack in the sheet. Now you are ready to hoist the spinnaker. Start by heading off to a square run. Leave the mainsail fully out during the hoisting procedure as it will blanket the spinnaker and keep it from filling until you are ready for it to be set. A good place to raise the sail is from the leeward side, just ahead of the boom. Once it is fully hoisted, slowly head up to your desired course and pull in the sheet until the sail sets. Make sure you have at least two turns of the sheet around the winch.

Now you are off and sailing with your cruising spinnaker.

12.9 Roller Furling System

There are two sets of jib furling systems, Headsail furling and optional Staysail furling system. Furling and reefing systems plus the support hardware and kits to make sailing more enjoyable. Furling systems are wonderful for short handed sailing. They make it quick and easy to douse a sail.

12.9.1 Head Sail Furling System:

The top of the furling system attach to forestay attachment on masthead rigs, and the lower end fitted with fork toggle to the boat's bow roller assembly (part of stemhead).

The furling system contains furling line, lower bearing assembly with shackle and halyard swivel with snap shackle.

Headsail furling system, the lower end fitted and attached on bow roller assembly. The furling line routed to turning block on bow rail and continuing routed through line blocks on starboard stanchions afterward passes through the standing block then locked on single-sheet stopper on coaming

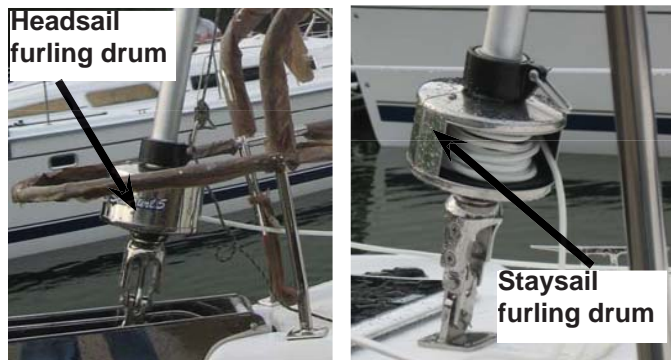

Fig. 12.3 Headsail & Staysail Furling System

12.9.2 Staysail Jib Furling System (Option)

The top of staysail furling system attach to inner stay attachment on mast just above the upper spreader, and the lower end fitted with fork toggle to carriage hole on the forward chainplate that is located behind the sail locker hatch hatch.

Staysail furling system, the furling line routed to turning

block on port side bow rail leg and continuing routed through line blocks on port stanchions afterward passes through the standing block then locked on single-sheet stopper on coaming.

12.9.3 Dual Mainsheet Control System

Mainsheet is double-end control. It can be adjusted at the base of port arch leg or jib sheet winch when not in use.

12.10 The Arch

As is customary on Hunters, the traveler is overhead, on a stainless-steel arch, to keep the cockpit clear of the obstruction and the boom clear of your head. The helmsman can easily adjust the mainsheet traveler and the jib sheets, although the mainsheet itself is also at the companionway as illustrated above. The setup allows short handed sailing when there are only a couple of people in the cockpit or with an autopilot doing the steering.

For instructions on folding the arch for transport or service please follow the following instructions:

Arch installation notes and tool list:

Notes: Read all of the installation instructions before beginning.

- This job requires two people, it is important that the arch be supported until firmly attached to the deck.
- To avoid injury during the installation process, orient the arch prior to beginning the installation.
- Remember to check all arch nuts bolts after the initial sea trial and tighten as necessary.

Tool List for arch installation:

- Drill and 3/8" drill bit, to clear sealant from holes.
- 3/8" drive ratchet
- 6" extension
- 9/16" deep and regular socket.
- 9/16" wrench
- Phillips head screwdriver (large: P4)
- Caulk gun, and sealant (3M-5200)
- 'Never Seize" bolt lube
- Razor knife
- Wire strippers / crimps
- Rags, and acetone, or lacquer thinner for clean-up.

12.11 Protecting Your Rigging

Without careful inspection and proper maintenance, the rigging is subject to fatigue, wear, discoloration, and therefore, product failure. Remember: regular inspection and cleaning will increase the life of your investment and secure your rigging. We suggest the following:

- Always rinse your rigging with fresh water after sailing, especially salt-water sailing. Salt can create corrosion pits, causing cracks and deterioration.
- Clean with a water-soluble chlorine-free detergent. Nonabrasive cleansers are best for hard white vinyl coated cables.
- Inspect rigging for stains. Rust stains may indicate stress cracks or corrosion. Remove stains with synthetic or brass pads. Never use steel wool pads.
- Look for broken wires- a sign of fatigue in rigging. Replace standing rigging if wires are broken.
- Never mix stainless steel and galvanized metals on cable, fittings, pins, cotter keys, etc. If mixing dissimilar metals, electric currents may conduct between metal causing rapid deterioration
- Store rigging in a dry place. Never store in a plastic bag, which can cause corrosion.

12.11.1 Sail Care

Sunlight is a sail's worst enemy, so **cover the mainsail when not in use**. An ultraviolet guard, fitted down the leech of a roller headsail will protect the exposed part from the weathering effect of the sun and from dirt and grit. Mildew, can be prevented by storing sails dry and by hand washing twice a season. Check all sails regularly for chafe, particularly where they chafe on deck fittings or rigging, at reef points, batten sleeves and the foot of the headsail. Sail batten pockets should be inspected on a regular basis.

To stow the mainsail, start at the leech and flake it onto the boom, left and right, in about 18-in. (46 cm) folds, while pulling the leech aft. Secure with a sail tie and continue to the luff. Lash to the boom with sail ties or shock cord.

12.11.2 General Hardware Maintenance

Check all fittings regularly to be sure screws are tight. Occasionally lubricate (use silicone lubricants) all moving parts on such fittings as blocks, turnbuckles and cam cleats, as well as the locking pins of snatch blocks, track slides, spinnaker poles, etc. Inspect cleat and fairleads for roughness and smooth

with fine-grained emery paper if necessary. Also, replace any missing or damaged cotter pins in turnbuckles and shackles, and either tape them or use them or use protective covers manufactured for that purpose. Grease winches a minimum of once yearly.

12.11.3 Winch Maintenance

Follow the maintenance instructions prescribed by winch manufacturer. We recommend a minimum of an annual cleaning and light greasing.

50cc STANDARD STANDING RIGGING DETAILS

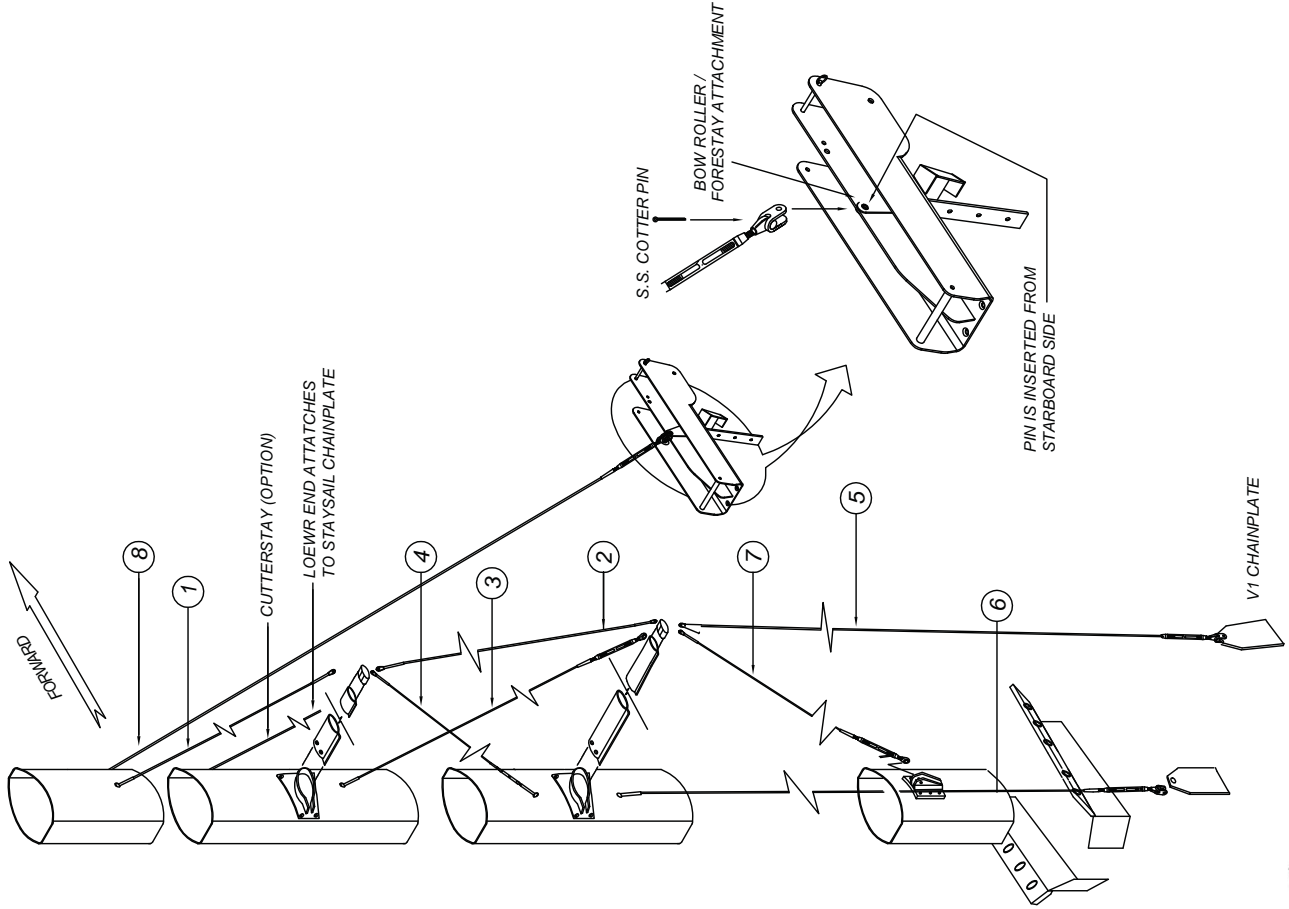

HUNTER 50c.c CONVENTIONAL STANDING RIGGING					
ITEM	QTY	WIRE SIZE	FITTINGS	CP / EOS	
1	2	3/8" 10 mm	EYE 308-365 FORK 308-318-01	18 ft. 2 1/2"	5550 mm
2	2	3/8" 10 mm	EYE 308-365 EYE 308-365	18 ft. 1/2"	5500 mm
3	2	5/16" 8 mm	STEMBALL 308-555 CUPS 306-574 STD/FORK TB 174-325-06	18 ft.	5485 mm
4	2	9/32" 7 mm 7/16"	FORK 308-315-01 STD/FORK TB 174-324-10	17 ft. 9 3/8"	5420 mm
5	2	1/2" 12 mm N/A 7/8"	FORK 308-318-01 BUSHING 306-539 <small>IN FORK</small> STD/TGLE TB NAVTEC N674-002828	18 ft. 7 1/4"	5670 mm
6	2	1/2" 12 mm 3/4"	STEMBALL 308-557 STD/TGLE TB 174-327-12	19 ft 1/2"	5805 mm
7	2	1/4" 6 mm 7/16"	FORK 308-314-01 STD/T TB 174-474-21	14 ft. 2 7/8"	4340 mm
8	FORESTAY 1	3/8" 10mm	FURLEX 310-17 OVERALL CP-CP 039-027-64	56 ft. 4 1/2"	17185 mm
	CUTTERSTAY 1	5/16" 8mm	FURLEX 308-15 OVERALL CP-CP 039-027-61	41 ft. 10"	12750 mm
	Option Not Shown				
			SRIG-6936T		

1. CP = CENTER PIN; EOS = END OF STUD
2. LENGTHS DO NOT INCLUDE SPREADER TIP LINKAGE.
3. MEASURE T-TERMINALS & STEMBALLS FROM TOP OF FITTING.

50cc FURLING STANDING RIGGING DETAILS

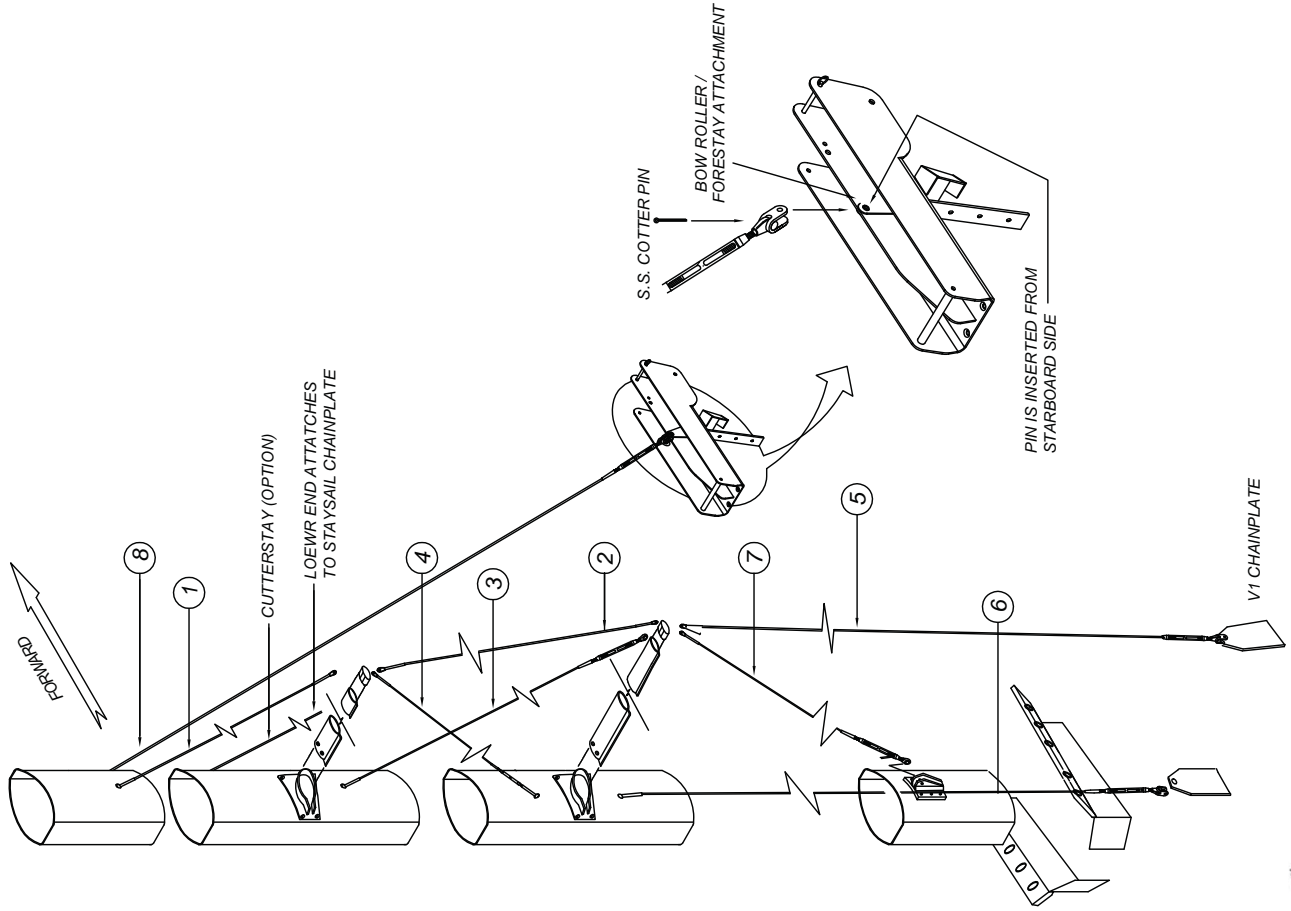

HUNTER 50cc FURLING STANDING RIGGING				
ITEM	QTY	WIRE SIZE	FITTINGS	CP-CP OR CP-EOS
1	2	3/8" 10 mm	EYE 308-365 FORK 308-318-01	18 ft. 2 1/2" 5550 mm
2	2	3/8" 10 mm	EYE 308-365 EYE 308-365	18 ft. 1/2" 5500 mm
3	2	5/16" 8 mm	T-TERMINAL 308-326 STD/FORK TB 174-325-06	16 ft. 11 1/8" 5160 mm
4	2	9/32" 7 mm	FORK 308-315-01 STD/FORK TB 174-324-10	17 ft. 9 3/8" 5420 mm
5	2	1/2" 12 mm	FORK 308-318-01 BUSHING 306-539 ^{IN FORK} STD/TGLE TB 674-002828	18 ft. 7 1/4" 5670 mm
6	2	1/2" 12 mm	EYE 308-366 STD/TGLE TB 174-327-12	18 ft 3 1/4" 5570 mm
7	2	1/4" 6 mm	FORK 308-314-01 STD/T TB 174-474-21	14 ft. 2 7/8" 4340 mm
8	FORESTAY 1	3/8" 10 mm	FURLEX 310-17 OVERALL CP-CP 039-027-64	56 ft. 4 1/2" 17185 mm
	INNERSTAY 5/16"	8 mm	FURLEX 308-15 OVERALL CP-CP 039-027-61	41ft 10" 12750 mm
	Option Not Shown			
SRIG-6732				

1. CP = CENTER PIN / EOS = ENDOF STUD
2. LENGTHS DO NOT INCLUDE SPREADER TIP LINKAGE.
3. MEASURE T-TERMINALS & STEMBALLS FROM TOP OF FITTING.

50cc STANDING RIGGING DETAILS

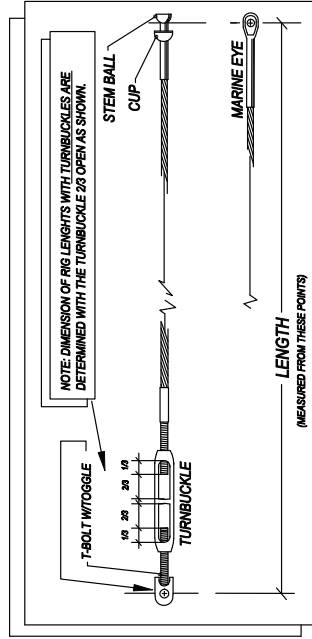

V = VERTICAL
 D = DIAGONAL
 RD = REVERSE DIAGONAL
 1 = LOWER
 2 = INTER.
 3 = UPPER

UPPER SPREADER TIP

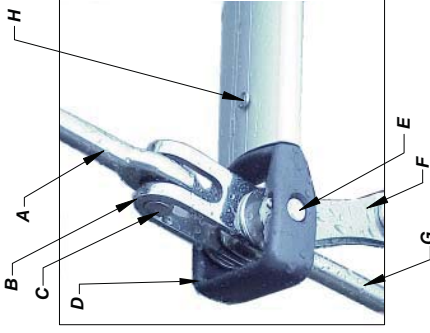

- A D3 marine eye
- B jaw toggle
- C 1/2" (1.27cm) pin
- D spreader tip casting
- E 3/8" (.95cm) pin
- F link plates
- G marine eye stem
- H spreader tip casting fastener

LOWER SPREADER TIP

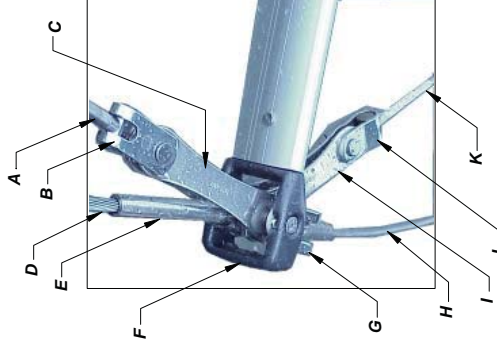

- A D2 stem T
- B jaw toggle
- C link plates
- D V2
- E marine eye
- F spreader tip casting
- G jaw toggle
- H V1
- I link plates
- J jaw toggle
- K RD1 stem T

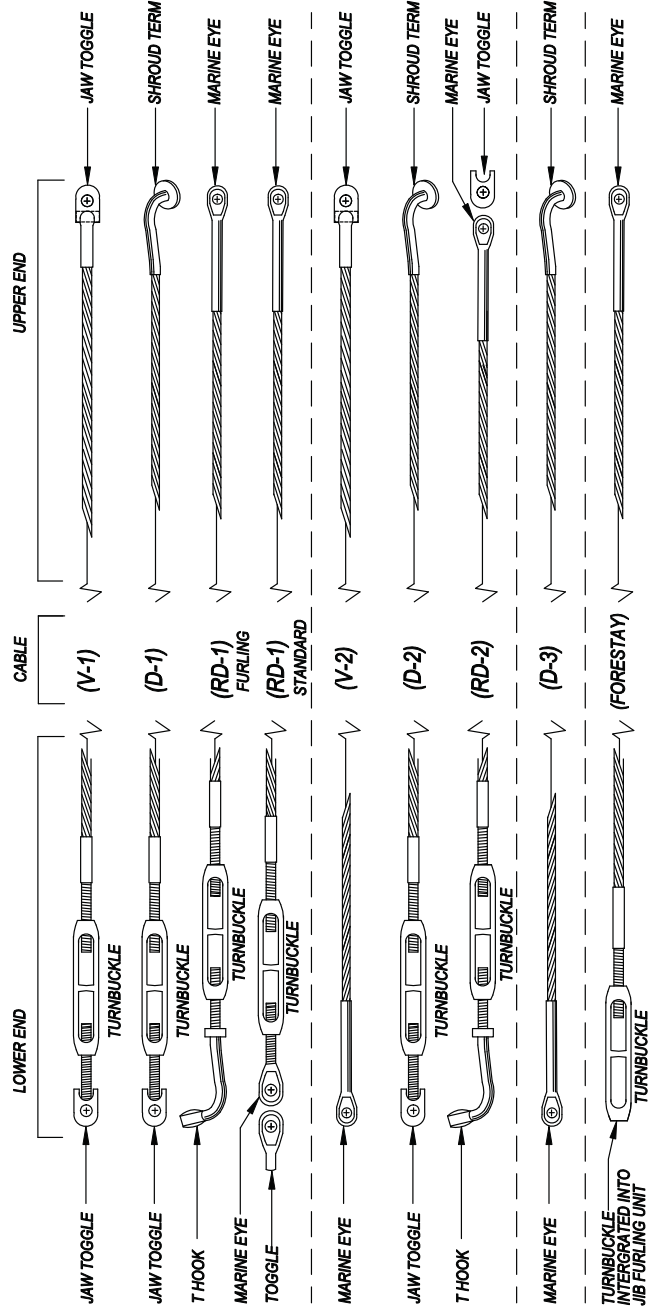

50cc FURLING MAST RUNNING RIGGING ARRANGEMENT

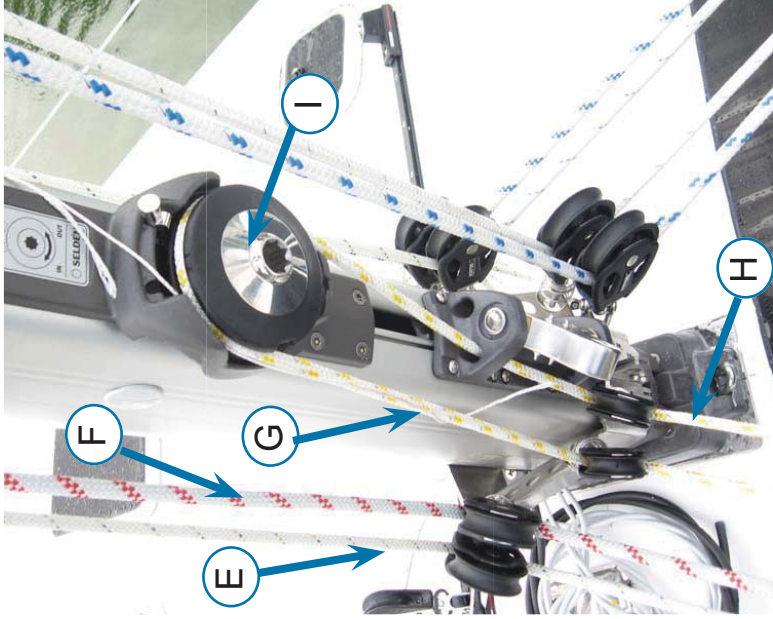

- E. SPINNAKER HALYARD (OPTION)
- F. JIB HALYARD
- G. REEF LINE (OUT)
- H. MAIN SAIL REEFING WINCH
- I. REEF LINE (IN)

Unfurling:

1. Free both sides of the reefing line from the winch and clam-cleat. 2. Pull out the sail with outhaul line,

Furling:

1. The leech should be kept fairly tight when reefing or furling. Adjust the topping to achieve this, and the sail will form a good tight roll around the luff extrusion. 2. Use reefing winch to take on the reef line. 3. Keep slight tension on the outhaul when doing this. The procedure applies to especially when the wind is abaft the beam or in light air. 4. Always lock the reefing winch when leaving the boat.

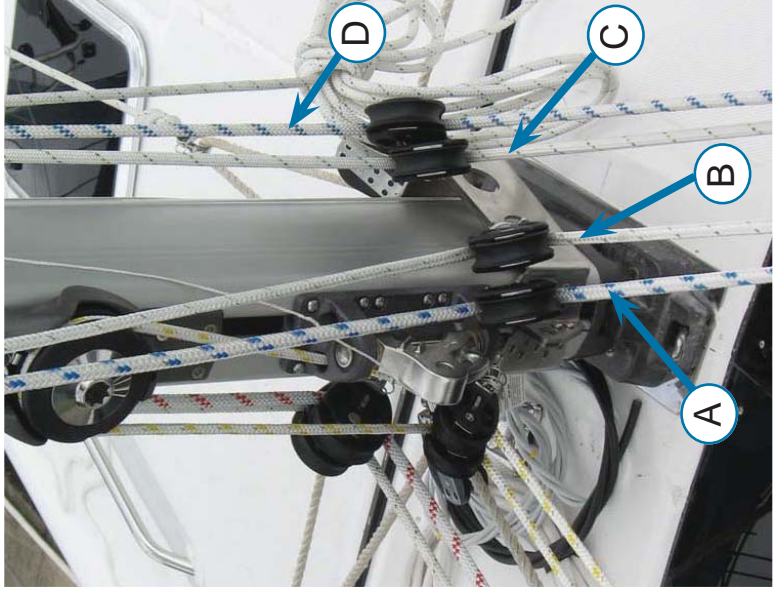

- A. MAINSHEET
- B. MAIN SAIL OUTHAUL
- C. MAIN HALYARD
- D. STAYSAIL HALYARD (OPTION)

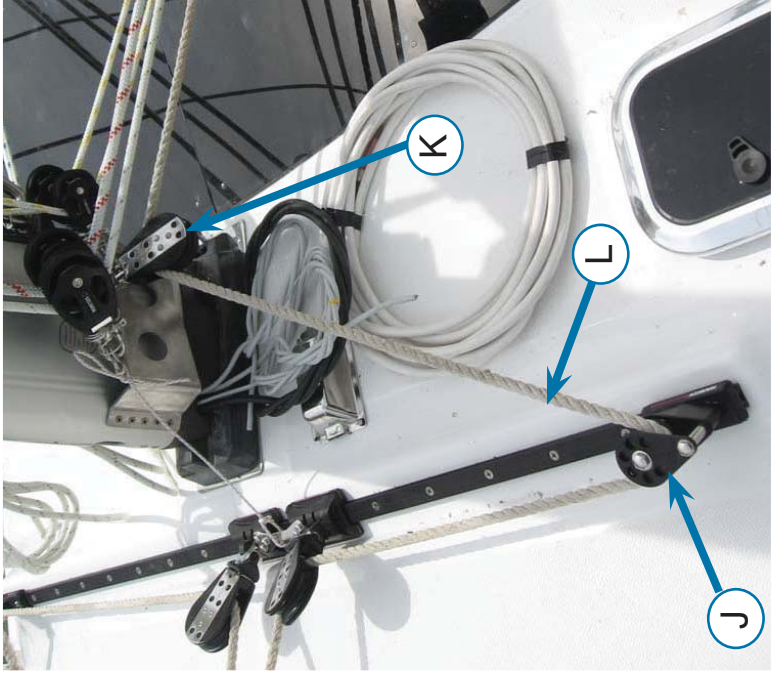

- J. STAYSAIL SHEET TURNING BLOCK
- K. STAYSAIL SHEET TURNING BLOCK
- L. STAYSAIL SHEET

Note: See the Equipment Manufacturer's manual for more detail information on the operating of furling mast.



50CC REEFING AND ROPE VANG ARRANGEMENTS

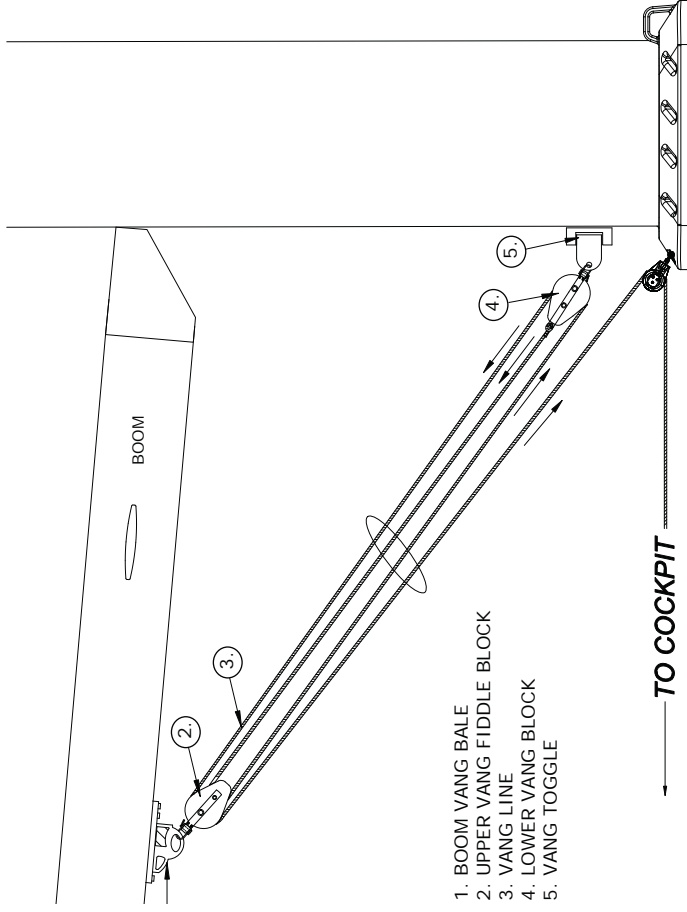
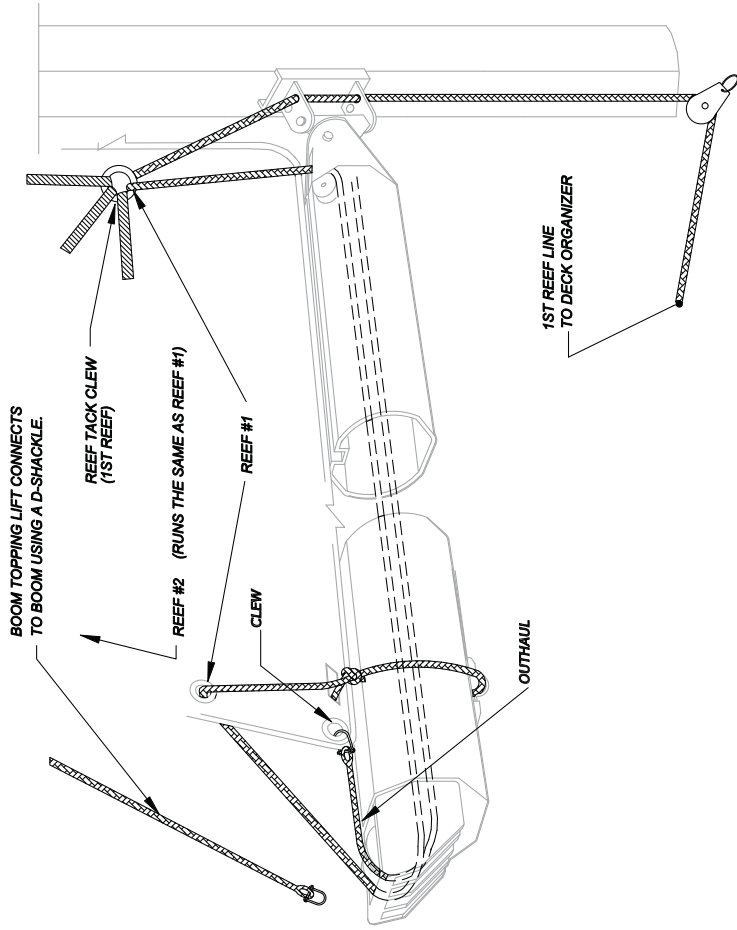

1. BOOM VANG BALE
2. UPPER VANG FIDDLE BLOCK
3. VANG LINE
4. LOWER VANG BLOCK
5. VANG TOGGLE

TYPICAL REEFING PROCEDURE (STANDARD MAST ONLY)

1. Head up into the wind.
2. Ease the mainsheet and vang.
3. Check the topping lift for adequate boom support.
4. Lower the main halyard to the appropriate mark and snub the line with the stopper.
5. Tension the reefing line with the self-tailing winch until the reef clew is brought down to the boom. Apply stopper and tension the main halyard back up, ease the topping lift (if needed).

TYPICAL ROPE VANG INSTALLATION:

1. Attach and install the lower fiddle block on vang toggle
2. Attach the vang upper fiddle block on vang bale of the boom.
3. Run the vang line as shown in the figure.
4. Continue to run the vang line through vang line block then after wars to the deck organizer and to the designated sheet stopper.
5. Confirm All attachments are Secure.



50cc FITTING RODKICKER GAS CYLINDER

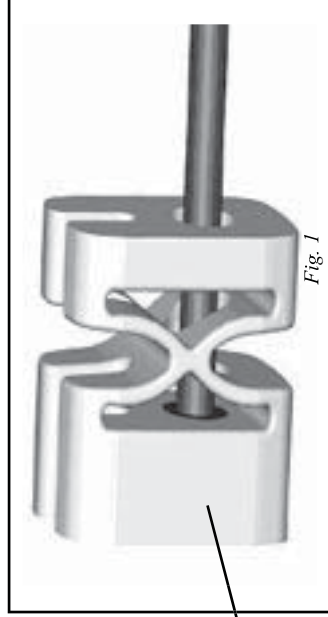

Fig. 1

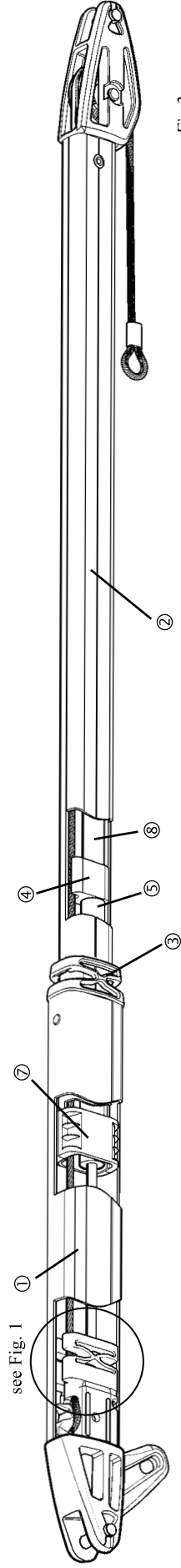

Fig. 2

Rodkicker Gas Cylinder Installation:

1. Remove the upper bushing ③ by pressing both snap-fasteners simultaneously.
2. Withdraw the small tube ②.
3. Shake out the lower end-plug ⑥ from the larger tube ①.
4. Remove the gas cylinder ③ from its wrappings.
5. Screw the thin end of the gas cylinder into the lower end-plug ⑥.
6. Hold the wire clear and push the gas spring ⑤ into the larger tube ①. The thinner part with the end plug down to the end fitting.
7. Fit the upper bushing ④ into the spacer tube ②.
8. Insert the spacer tube ② into the smaller tube. The upper bushing ④ to be inside the smaller tube with the upper bushing down.
9. Screw the gas spring ⑤ into the upper end-plug ④.
10. Slide the small tube ② into the larger tube ①. Make sure that the gliding insert ⑦ is in its place around the smaller tube.
11. Push the bushing ③ down, and lock it in place with its snap-fasteners.



50cc FITTING THE RODKICKER AND BOOM VANG ARRANGEMENT

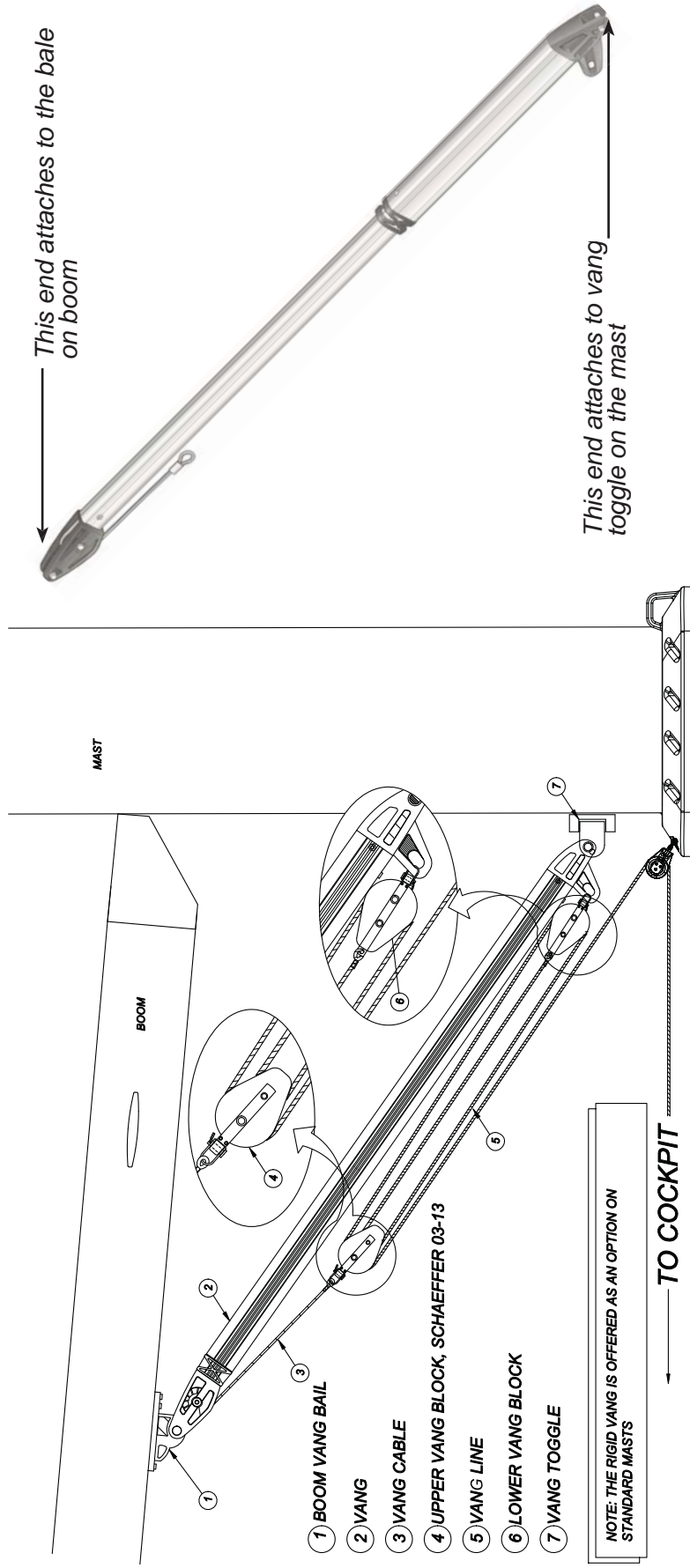

- 1 BOOM VANG BAIL
- 2 VANG
- 3 VANG CABLE
- 4 UPPER VANG BLOCK, SCHAEFFER 03-13
- 5 VANG LINE
- 6 LOWER VANG BLOCK
- 7 VANG TOGGLE

NOTE: THE RIGID VANG IS OFFERED AS AN OPTION ON STANDARD MASTS

TO COCKPIT

Fitting the Rodkicker:

1. Fit the boom-slider so that it is moveable along the boom. If the boom has a fitting that cannot be moved, great care must be taken to avoid damaging the Rodkicker.
2. Fit the Rodkicker to the boom and mast fittings. Ensure that the boom slider can slide, so that the Rodkicker is not subjected to any compression forces. Hoist the mainsail, and sheet home hard whilst ensuring that the Rodkicker does not "bottom".
3. Keep the boom in the position, compress the Rodkicker with its tackle until the upper fitting just contacts the upper bushing. If a gas cylinder is fitted, a force of 700 N (70 kg) is required.
4. Move the slider and mark its new position. Provisionally fix the slider approximately 5 mm (3/16") AFT OF the mark.
5. With the main still hoisted check that the Rodkicker does not "bottom". Repeat hoisting and checking with the mainsail reefed—go through all reefs.
6. Allow the boom to rest, and check its level in relation to the spray hood, wind screen, lifelines etc.
7. Secure the boom-slider in its permanent position.



50cc DUAL END MAINSHEET PURCHASE ARRANGEMENT

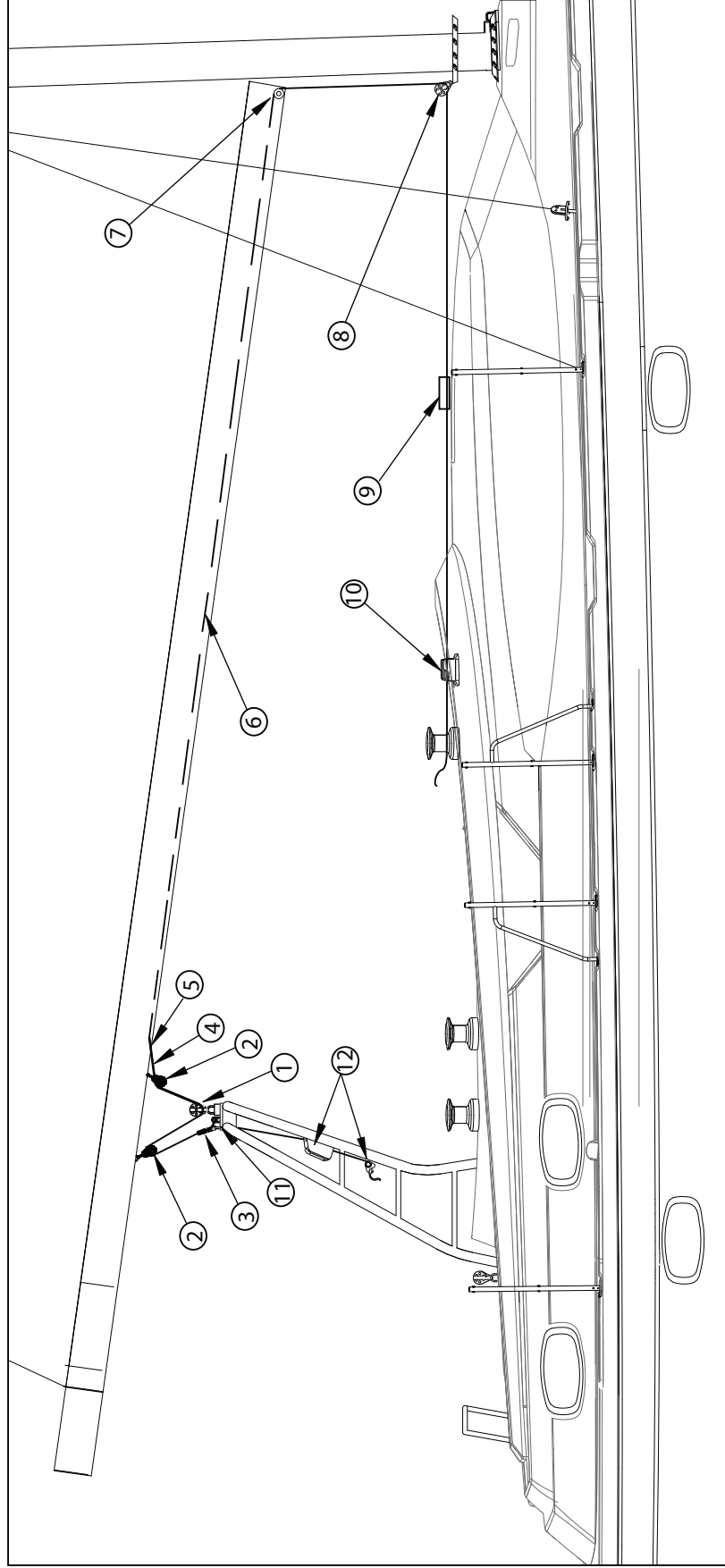

- 1 BLOCK ON TRAVELER CAR
- 2 BOOM BALE AND MAINSHEET BLOCK
- 3 ARCH BLOCK ON BALE TO ARCH UPPER SHEAVE
- 4 MAINSHEET
- 5 MAINSHEET BOOM EXIT
- 6 MAINSHEET RUN INSIDE BOOM
- 7 MAINSHEET SHEAVE INSIDE FWD BOOM END
- 8 MAINSHEET BLOCK AT MAST STEP
- 9 MAINSHEET THRU BLOCK ORGANIZERS
- 10 MAINSHEET THROUGH SHEET STOPPER TO WINCH
- 11 ARCH UPPER SHEAVE FOR MAIN SHEET (PORT SIDE)
- 12 MAINSHEET THROUGH SHEET STOPPER AND BLOCK TO CAMCLEAT



50cc STANDARD RUNNING RIGGING

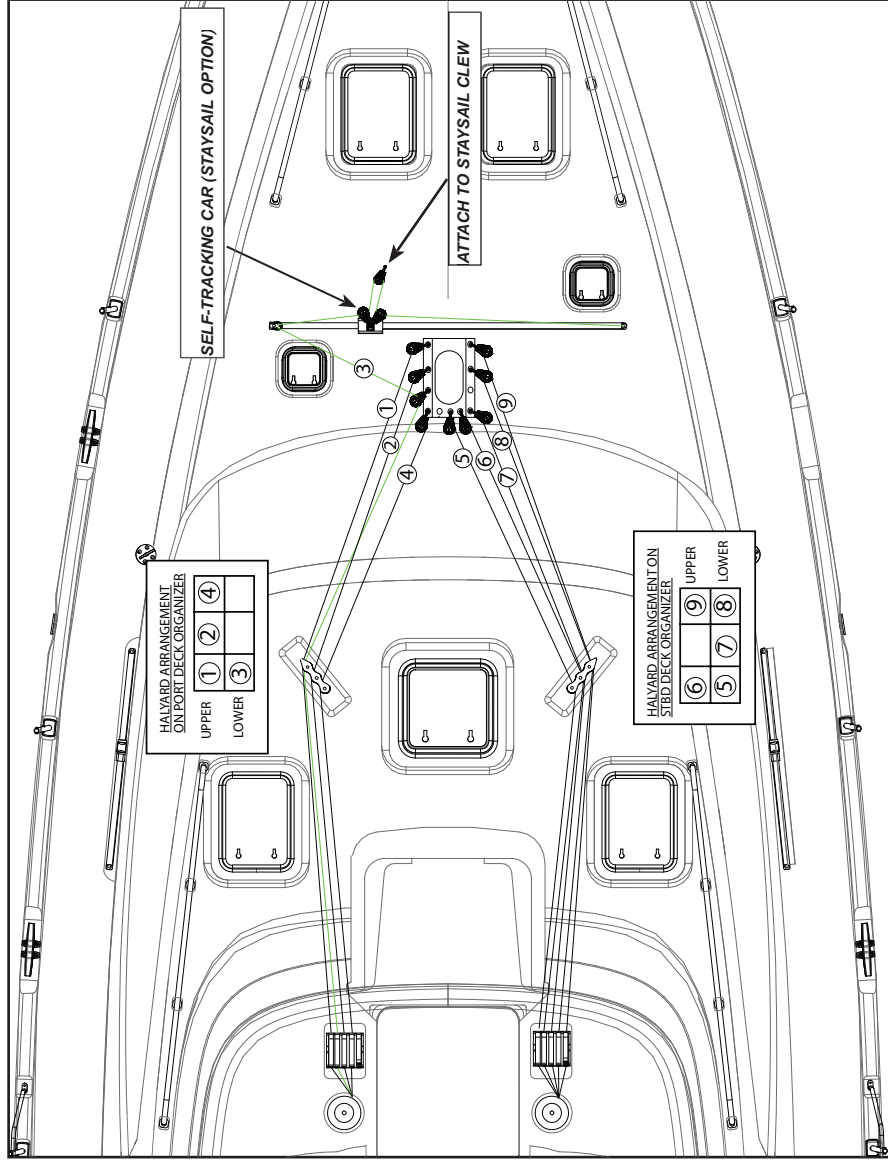

- 1 * OPTIONAL SPINNAKER HALYARD
- 2 * JIB HALYARD *
- 3 SELF TACKLING JIB SHEET
- 4 #2 MAIN SAIL REEF
- 5 VANG LINE
- 6 #1 MAIN SAIL REEF
- 7 MAINSHEET
- 8 MAIN HALYARD
- 9 *OPTIONAL STAYSAIL HALYARD

* RUNS THROUGH DECK ORGANIZER UPPER BLOCK

RUNNING RIGGING SPECIFICATIONS											
Boat: HUNTER 50cc CONV TALL \$elden Mast # RRIIG-6936T Date:											
OPT/STD	ITEM	QTY	Line Size	Line Type	Color	End 1	End 2	Length	End 1	End 2	End 2
1 STD	MAIN HALYARD	1	14mm (1/2")	32/3 pl	BLUE	307-444 SHACKLE/Knot	BARE	44 m	145ft	BARE	BARE
2 STD	JIB HALYARD	1	14mm (9/16")	32/3 pl	RED	307-047 SHACKLE/Knot	BARE	40.5 m	132ft	BARE	BARE
3 STD	MAIN TRAVELER LINE	2	10mm (3/8")	16/16 pl	WHITE	EYE	BARE	9 m	29ft	BARE	BARE
4 STD	MAINSHEET	1	14mm (9/16")	16/16 pl	BLUE	EYE	BARE	52 m	170ft	BARE	BARE
5 STD	REEFING LINE #1	1	14mm (9/16")	32/3 pl	BLUE	BARE	BARE	22 m	72ft	BARE	BARE
6 STD	REEFING LINE #2	1	14mm (9/16")	32/3 pl	RED	BARE	BARE	28 m	92ft	BARE	BARE
7 STD	JIB SHEETS	2	14mm (9/16")	16/16 pl	RED	BARE	BARE	25 m	82ft	BARE	BARE
8 OPT	SELF TACKLING SHEET	1	12mm (1/2")	32/3 pl	RED	BARE	BARE	27	89ft	BARE	BARE
9 OPT	CRUISING SPINN. SHEET	2	12mm (1/2")	16/16 pl	WHITE	BARE	BARE	30.5 m	100ft	BARE	BARE
10 OPT	SPINNAKER HALYARD	1	14mm (9/16")	32/3 pl	WHITE	307-339 Shackle / Knot	BARE	43 m	141ft	BARE	BARE
11 STD	RODKICKER TACKLE	1	12mm (1/2")	16/16 pl	WHITE	EYE	BARE	9 m	30ft	BARE	BARE
12 STD	BOOM TOPPING LIFT	1	10mm (3/8")	32/3 pl	WHITE	307-037 / Knot	BARE	44 m	145ft	BARE	BARE
13 OPT	STAYSAIL HALYARD	1	12mm (1/2")	32/3 pl	BLUE	307-339 Shackle / Knot	BARE	33m	108ft	BARE	BARE
14 OPT	STAYSAIL SHEET	1	12mm (1/2")	32/3 pl	RED	BARE	BARE	27m	89ft	BARE	BARE
15 STD	LAZY JACK WIRE	2	4mm (5/32")	PVC Wire	WHITE	307-010 Shackle	Block	6m	20ft	Block	Block
16 STD	Fixed Lazy Jack Line	2	10mm (3/8")	16/16 pl	WHITE	BARE	BARE	8m	26ft	BARE	BARE
17 STD	Adjustable Lazy Jack Line	2	10mm (3/8")	16/16 pl	WHITE	Plastic Thimble	BARE	9m	30ft	BARE	BARE

50cc FURLING RUNNING RIGGING

RUNNING RIGGING SPECIFICATIONS

Boat: HUNTER 50cc FURL

Selden Mast # RRIIG-6732

Date:

OPT/STD	ITEM	QTY	Line Size	Line Type	Color	End 1	Length	End 2
1 STD	MAIN HALYARD	1	12mm (1/2")	HMPE	WHITE	EYE	40 m	131ft
2 STD	JIB HALYARD	1	14mm (9/16")	32/3 pl	RED	307-047 SHACKLE/Knot	40.5 m	132ft
3 STD	MAIN TRAVELER LINE	2	10mm (3/8")	16/16 pl	WHITE	EYE	9 m	29ft
4 STD	MAINSHEET	1	14mm (9/16")	16/16 pl	BLUE	EYE	52 m	170ft
5 STD	JIB SHEETS	2	14mm (9/16")	16/16 pl	RED	BARE	25 m	82ft
6 OPT	SELF TACKING SHEET	1	12mm (1/2")	32/3 pl	RED	BARE	27	89ft
7 OPT	CRUISING SPINN. SHEET	2	12mm (1/2")	16/16 pl	WHITE	BARE	30.5 m	100ft
8 OPT	SPINNAKER HALYARD	1	14mm (9/16")	32/3 pl	WHITE	307-339 SHACKLE / Knot	43 m	141ft
9 STD	RODKICKER TACKLE	1	12mm (1/2")	16/16 pl	WHITE	EYE	9 m	30ft
10 STD	BOOM TOPPING LIFT	1	10mm (3/8")	32/3 pl	WHITE	307-037 / Knot	40 m	131ft
11 OPT	STAYSAIL HALYARD	1	12mm (1/2")	32/3 pl	BLUE	307-339 Shackle / Knot	33m	108ft
12 OPT	STAYSAIL SHEET	1	12mm (1/2")	32/3 pl	RED	BARE	27m	89ft
13 STD	FURLIN LINE	1	10mm (3/8")	16/16 pl	YELLOW	BARE	20m	65ft

RUNNING RIGGING SPECIFICATIONS

Boat: HUNTER 50cc FURL TALL

Selden Mast # RRIIG-6732T

Date:

OPT/STD	ITEM	QTY	Line Size	Line Type	Color	End 1	Length	End 2
1 STD	MAIN HALYARD	1	12mm (1/2")	HMPE	WHITE	EYE	44 m	145ft
2 STD	JIB HALYARD	1	14mm (9/16")	32/3 pl	RED	307-047 SHACKLE/Knot	40.5 m	132ft
3 STD	MAIN TRAVELER LINE	2	10mm (3/8")	16/16 pl	WHITE	EYE	9 m	29ft
4 STD	MAINSHEET	1	14mm (9/16")	16/16 pl	BLUE	EYE	52 m	170ft
5 STD	JIB SHEETS	2	14mm (9/16")	16/16 pl	RED	BARE	25 m	82ft
6 OPT	SELF TACKING SHEET	1	12mm (1/2")	32/3 pl	RED	BARE	27	89ft
7 OPT	CRUISING SPINN. SHEET	2	12mm (1/2")	16/16 pl	WHITE	BARE	30.5 m	100ft
8 OPT	SPINNAKER HALYARD	1	14mm (9/16")	32/3 pl	WHITE	307-339 SHACKLE / Knot	43 m	141ft
9 STD	RODKICKER TACKLE	1	12mm (1/2")	16/16 pl	WHITE	EYE	9 m	30ft
10 STD	BOOM TOPPING LIFT	1	10mm (3/8")	32/3 pl	WHITE	307-037 / Knot	44 m	145ft
11 OPT	STAYSAIL HALYARD	1	12mm (1/2")	32/3 pl	BLUE	307-339 Shackle / Knot	33m	108ft
12 OPT	STAYSAIL SHEET	1	12mm (1/2")	32/3 pl	RED	BARE	27m	89ft
13 STD	FURLIN LINE	1	10mm (3/8")	16/16 pl	YELLOW	BARE	20m	65ft

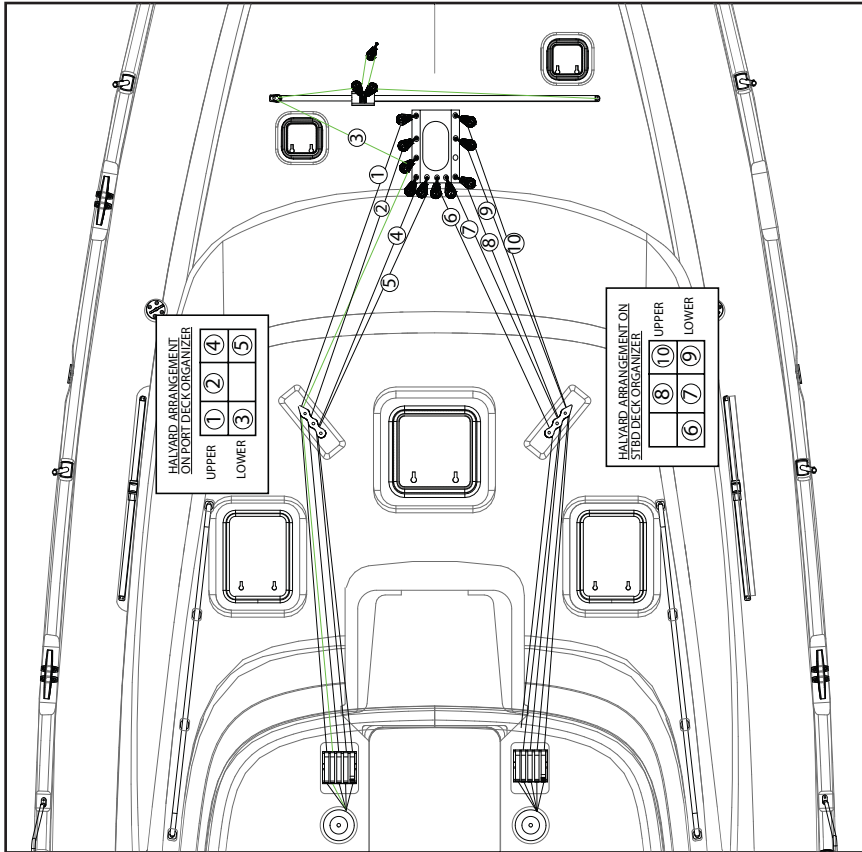

- 1 * OPTIONAL SPINNAKER HALYARD
- 2 * JIB HALYARD
- 3 SELF - TACKING JIB SHEET *
- 4 *FURLING LINE REEFING IN
- 5 FURLING LINE REEFING OUT
- 6 VANG LINE
- 7 OUTHAUL
- 8 * MAINSHEET
- 9 MAIN HALYARD
- 10 * STAYSAIL HALYARD

* RUNS THROUGH DECK ORGANIZER UPPER BLOCK



50cc OVERLAPPING JIB SELF-TACKING ARRANGEMENT

1. JIB SHEET CAR & TRACK
2. JIB SHEET BAIL FOR DEAD END
3. JIB SHEET TRACK TURNING SHEAVE
4. STAYSAIL SHEET TURNING BLOCK
5. DOUBLE STACK DECK ORGANIZER
6. SHEET STOPPER
7. PORT COACH ROOF WINCH
8. JIB CLEW BLOCK
9. JIB SHEET CAR BLOCK

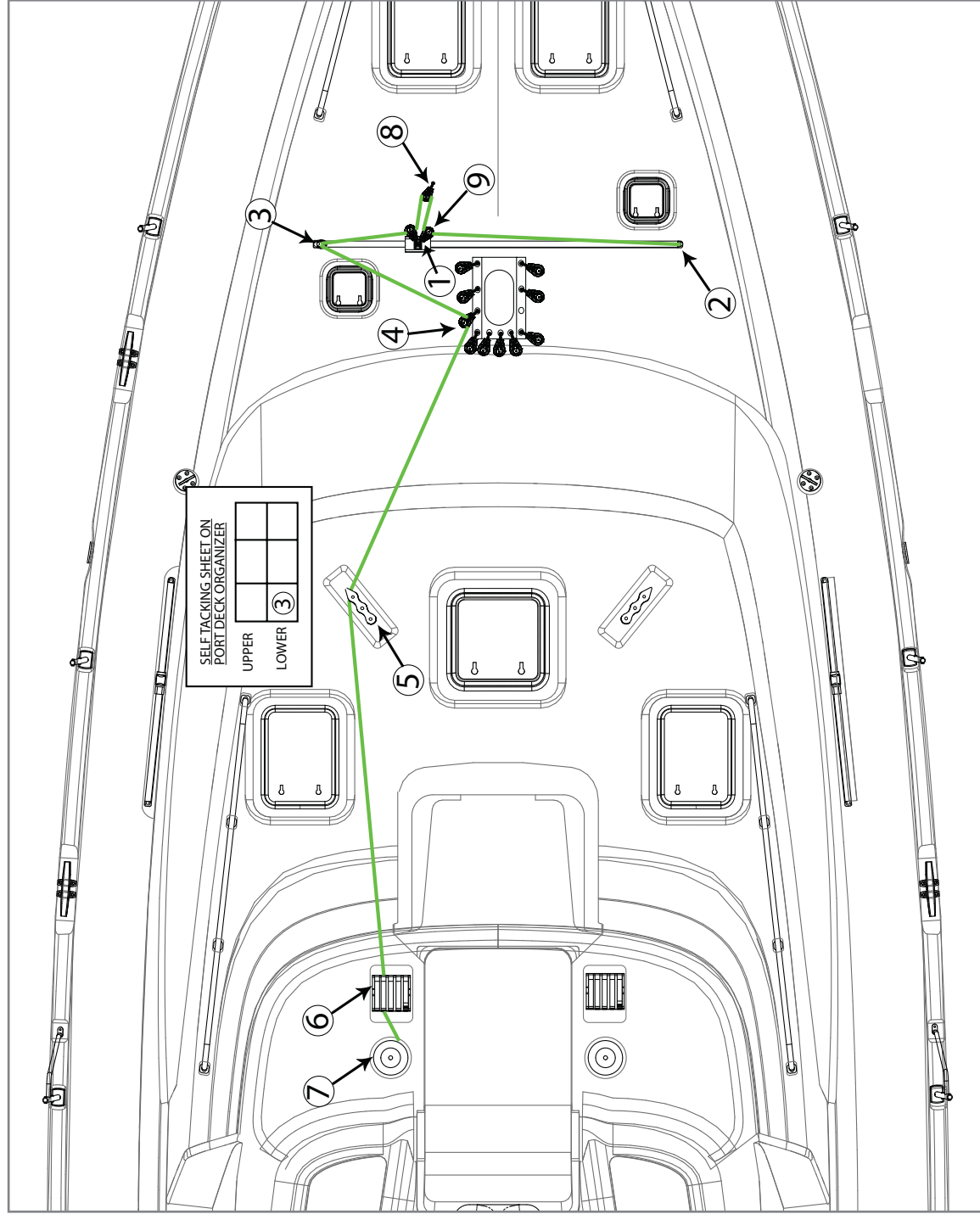

50cc JIB FURLING LINE LAYOUT

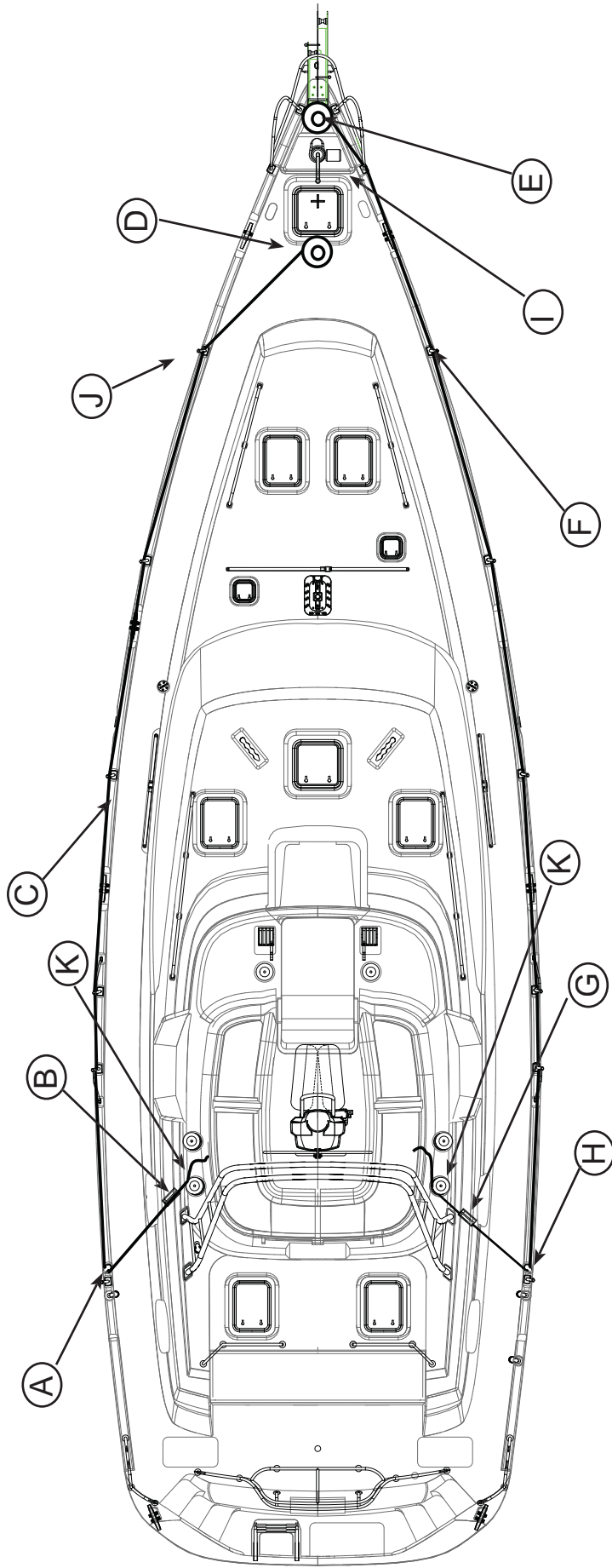

- A. STAYSAIL TURNING SHEAVE (OPTION)
- B. STAYSAIL SHEET STOPPER (OPTION)
- C. STAYSAIL FURLING LINE (OPTION)
- D. STAYSAIL FURLING DRUM (OPTION)
- E. JIB FURLING DRUM
- F. STANCHION FURLING LINE BLOCK. FURLING LINE RUNS THROUGH STANCHION BLOCKS

- G. FURLING JIB SHEET STOPPER
- H. FURLING JIB SHEET TURNING SHEAVE
- I. STANCHION MOUNT FURLING LINE TURNING BLOCK
- J. STANCHION MOUNT STAYSAIL FURLING LINE TURNING BLOCK
- K. WINCH



50cc MAINSHEET TRAVEL ARRANGEMENT AND COCKPIT DUAL MAINSHEET CONTROL SYSTEM

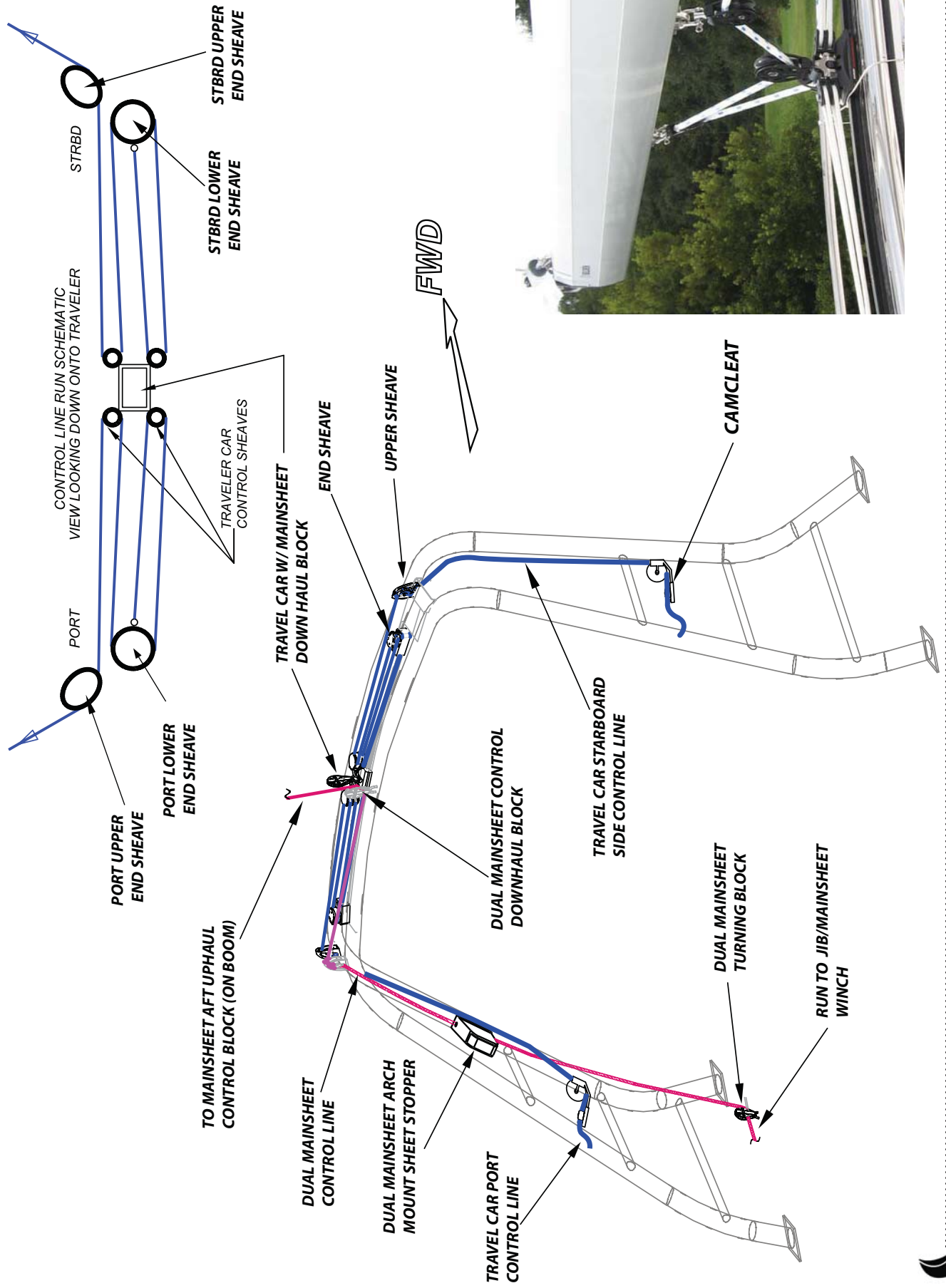

50cc STANDARD and FURLING SAILPLAN

FURLING SAILPLAN

P	50.61' (15.43m)
E	23.50' (7.16m)
I1	55.18' (16.82m)
J1	16.50' (5.02m)
I2	41.85' (12.76m)
J2	10.48' (3.19m)

VERTICAL BATTEN MAIN
 OVERLAP JIB
 STAYSAIL ON SELF-TACKING APPARATUS
 JIB SHEETS ON SIDE DECK

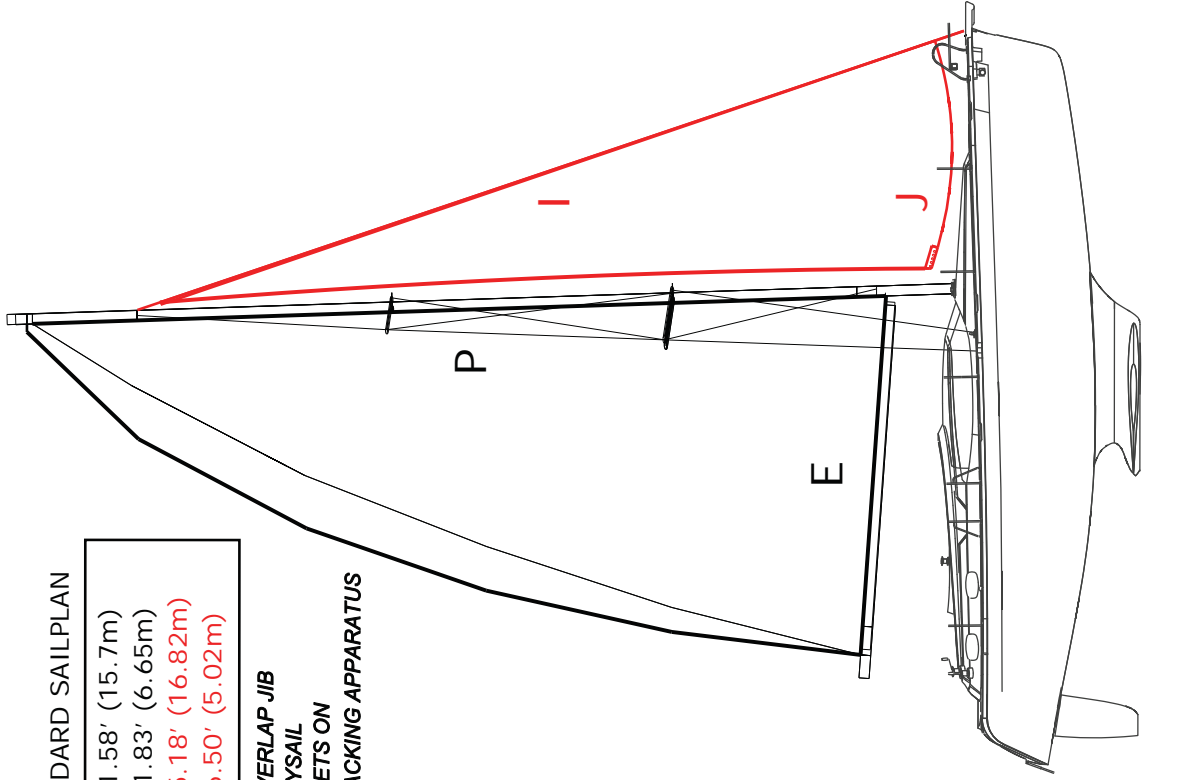

STANDARD SAILPLAN

P	51.58' (15.7m)
E	21.83' (6.65m)
I	55.18' (16.82m)
J	16.50' (5.02m)

NON-OVERLAP JIB
 NO STAYSAIL
 JIB SHEETS ON
 SELF-TACKING APPARATUS



50cc TALL RIG STANDARD and FURLING SAILPLAN

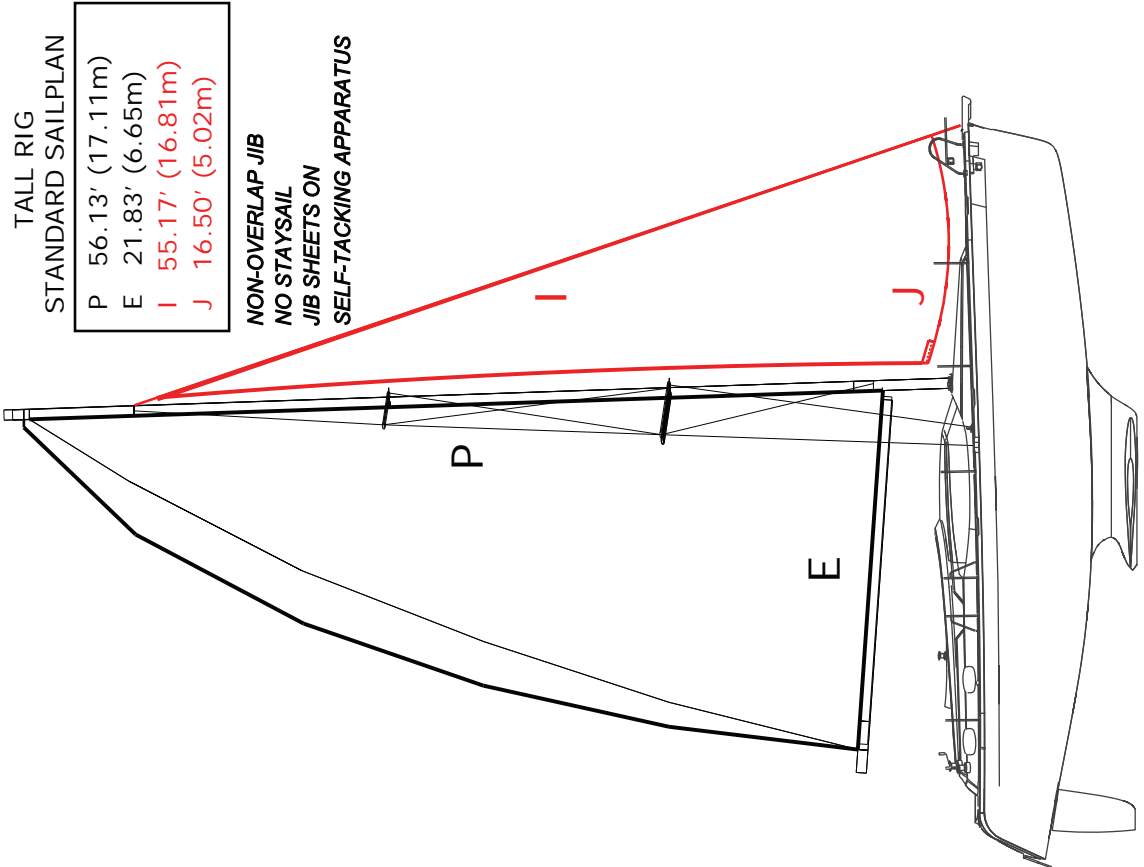

TALL RIG
STANDARD SAILPLAN

P	56.13'	(17.11m)
E	21.83'	(6.65m)
I	55.17'	(16.81m)
J	16.50'	(5.02m)

NON-OVERLAP JIB
NO STAYSAIL
JIB SHEETS ON
SELF-TACKING APPARATUS

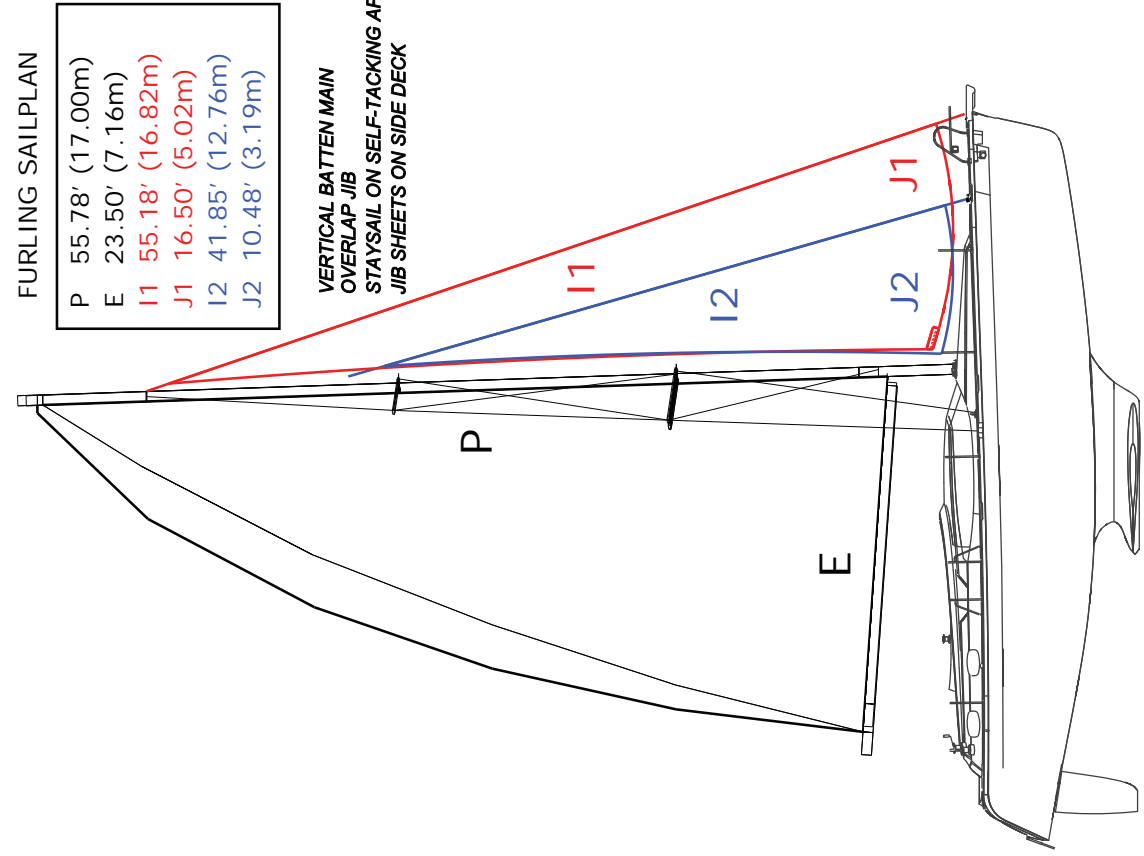

FURLING SAILPLAN

P	55.78'	(17.00m)
E	23.50'	(7.16m)
I1	55.18'	(16.82m)
J1	16.50'	(5.02m)
I2	41.85'	(12.76m)
J2	10.48'	(3.19m)

VERTICAL BATTEN MAIN
OVERLAP JIB
STAYSAIL ON SELF-TACKING APPARATUS
JIB SHEETS ON SIDE DECK



50cc LAZYJACK INSTALLATION

1. LAZYJACK WIRE ATTACHMENT @ UPPER SPREADER
2. LAZYJACK UPPER FIXED CABLE
3. THIMBLE OR BLOCK ON FIXED CABLE
4. FWD LAZYJACK LINE (THRU THIMBLE / BLOCK).
5. LOWER THIMBLE
6. AFT LAZYJACK LINE (THRU LOWER THIMBLE)
7. AFT BAIL (SECURE L.J. LINE END)
8. MID BAIL (SECURE OTHER END OF AFT L.J. LINE)
9. FWD BOOM L.J. CHEEK BLOCK (FWD L.J. LINE FED THRU)
10. LAZYJACK CLEAT ON BOOM (SECURE FWD L.J. LINE TO CLEAT)

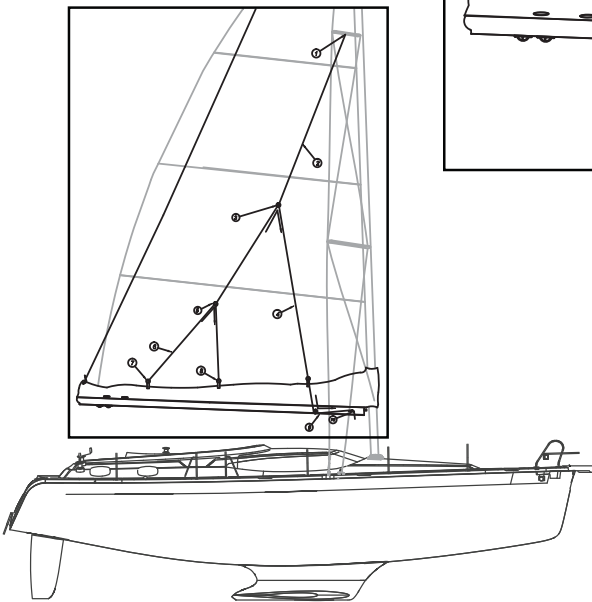
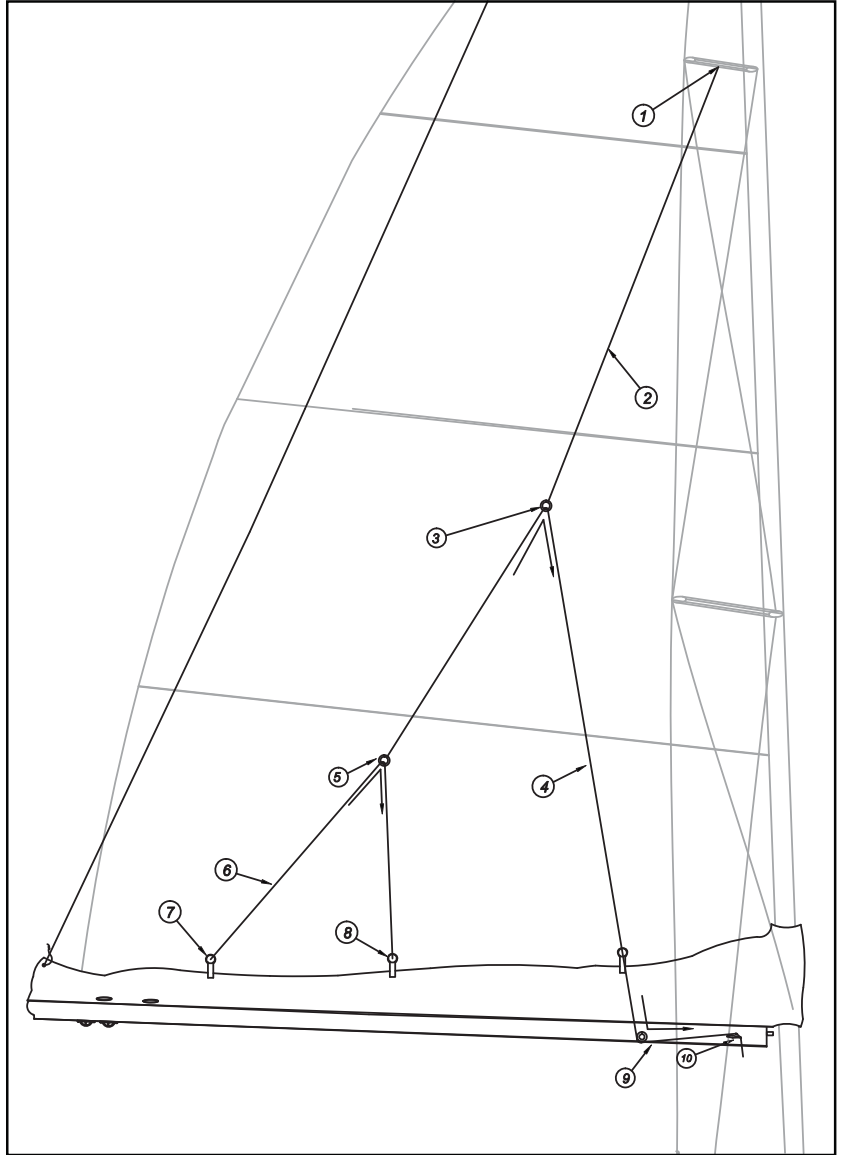

LAZYJACK SAILCOVER INSTRUCTION:

1. SLIDE THE BOLTROPE INTO BOOM TRACK 1 . START FROM THE AFT END AND MAKE YOUR WAY FORWARD.
2. INSTALL THE PVC BATTENS 2 INTO EACH HALF OF THE SAIL COVER. THERE ARE POCKETS 3, THAT OPEN TOWARDS THE FRONT, ON THE INSIDE OF THE COVER. SLIDE THE BATTENS INTO PLACE FROM THE FRONT, AND ROLL THE INSIDE LIP OF THE POCKET BACK IN ORDER TO HOLD THE BATTENS STATIONARY.
3. FEED THE LAZYJACK LINES 4 TO THE SAIL COVER 5 AND DEAD END THE LINES TO THE FWD AND AFT BAILS 6 ON THE SAIL COVER.
4. TIE THE AFT END OF THE SAIL COVER UP TO THE TOPPING LIFT LINE USING THE PIECE OF STRING PROVIDED 7 . USE HALF HITCH KNOTS TO SECURE THE COVER IN PLACE AT THE OUTER END OF THE BOOM. THE REEF LINES RUN OUT THROUGH THE COVER SLOTS 8 AND TIE OFF.

50cc SAILCOVER INSTALLATION (STANDARD MAST ONLY)

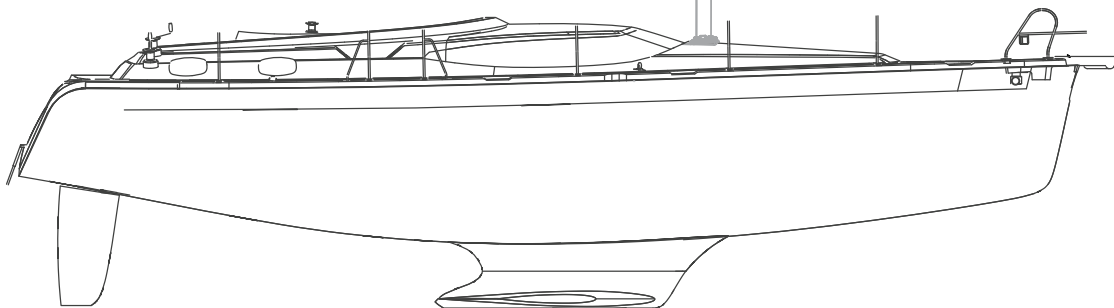
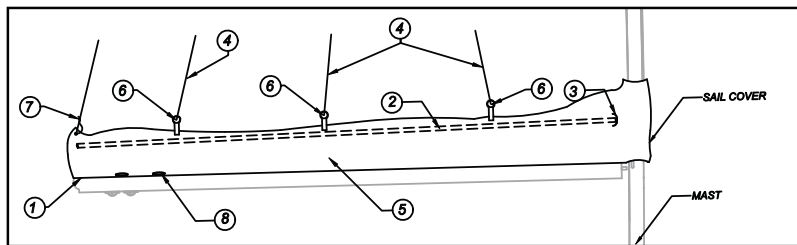
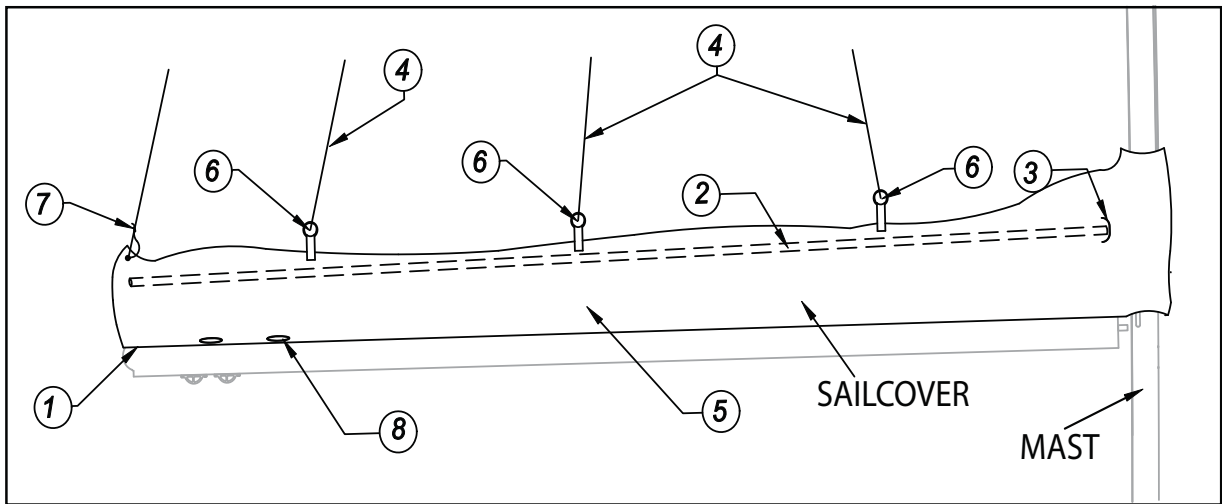

50cc SPINNAKER LAYOUT

- A. SPINNAKER WINCH
- B. SPINNAKER SHEET
- C. SPINNAKER SHEET BLOCK
- D. SPINNAKER TACK LINE CLEAT
- E. SPINNAKE TACK LINE

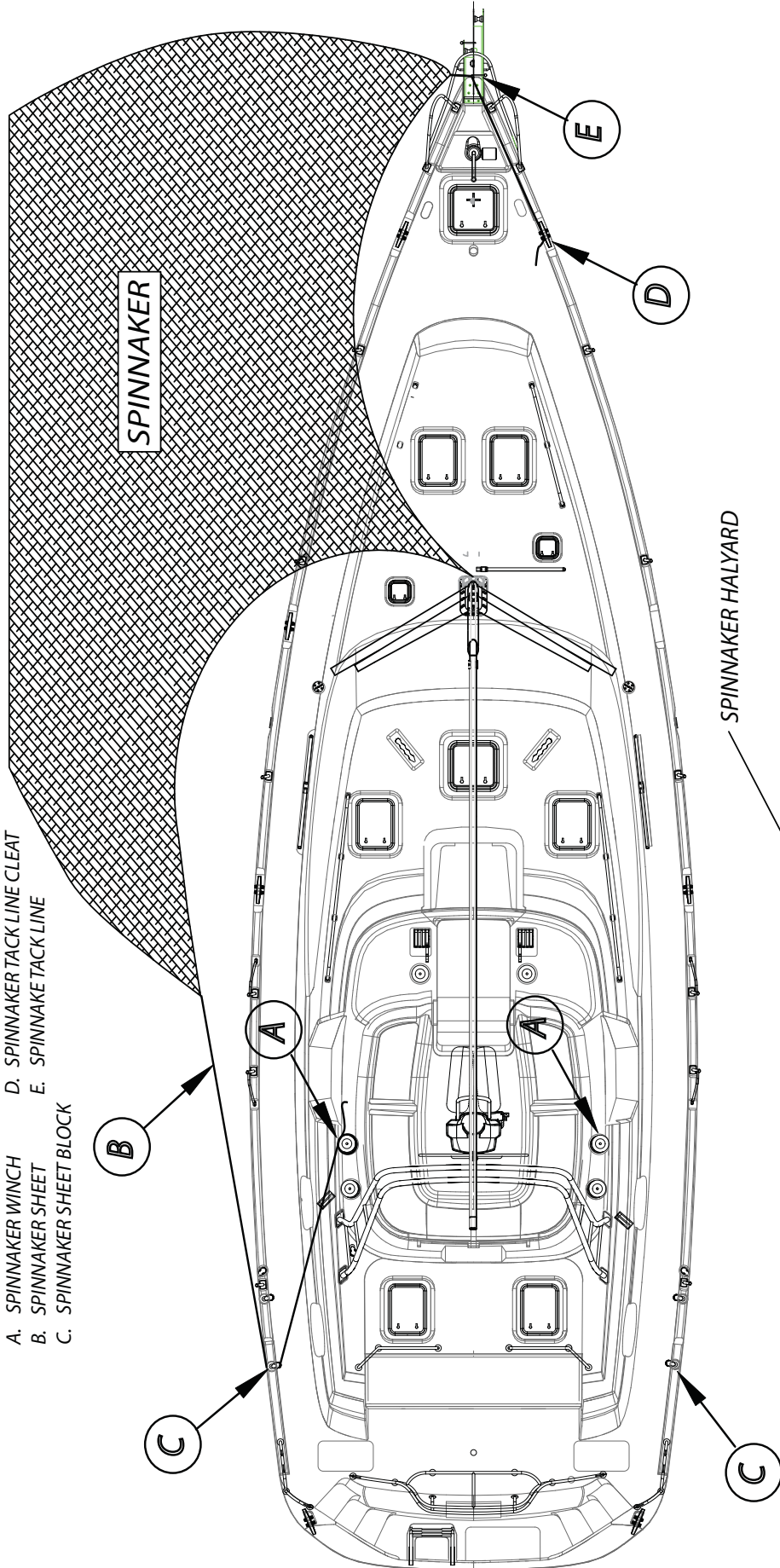

SPINNAKER HALYARD

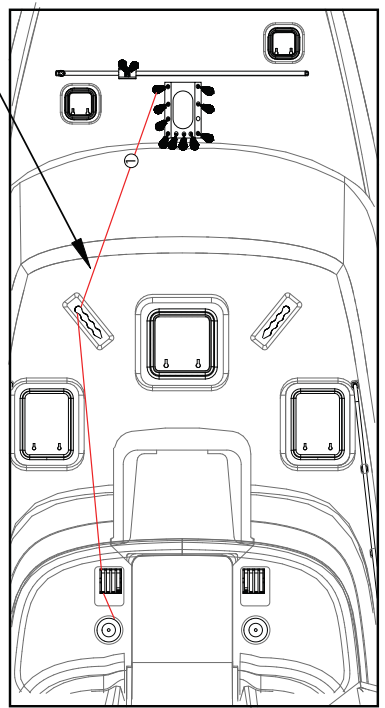



H U N T E R[®]

MARINE CORPORATION

AN EMPLOYEE OWNERSHIP COMPANY

We Go The Distance

Chapter 13

Getting

Underway

Hunter 50cc



Before you go on the first cruise, you should be able to answer “yes” to the following questions:

- Has your dealer completed the pre-delivery service inspection? Have you and your dealer signed the Pre-Delivery Inspection Report?
- Have you filled out and mailed all warranty registration cards?
- Have you read and do you understand this owner’s manual and the OEM manuals?
- Has your boat been registered with the proper authorities? Does your hull display the proper identification?
- Has your dealer reviewed with you the operation of the boat and its systems? Has your dealer answered all your questions?

If you have taken care of these preliminary steps, you are ready to take your first cruise. Before you start, give some thought to the cruise itself. Choose a calm day if you can.

13.1 Boarding your Boat

Make it a routine to visually inspect the exterior of your boat every time you approach it to board. Look for signs of damage that could be caused by the dock or other boats.

13.1.1 Preparing to Board

As you board your boat, you should listen for any alarms which could be sounding. The high water alarm at the helm will warn you of the high water bilge pump in operation. The CO detectors could indicate the presence of the deadly Carbon Monoxide gas. The dangers of Carbon Monoxide are detailed at length in the Boating Safety Chapter of this manual, and in the insert that is placed in the Boating Safety Chapter.

Note: There are other issues that could cause these alarms to sound such as the loss of power in the batteries that feed the CO detectors and the systems. This is so you are warned that you are nearing the loss of function of these important systems.



This alarm will only indicate the presence of Carbon

Monoxide at the sensor. Carbon Monoxide gas may be present in other areas.



Actuation of your CO alarm indicates the presence of Carbon Monoxide (CO) which will KILL YOU! If the alarm sounds:

1. Press the Reset/Silence button.
2. Call Emergency Services.
3. Immediately move to fresh air, outdoors, or to an open window or door. Do a head count to check that all persons are accounted for. Do not reenter the premises nor move away from an open door or window until the emergency responders have arrived, the premises have been aired out, and your alarm remains in its normal operation.
4. After following steps 1, 2, and 3, if your alarm reactivates in a 24 hour period, repeat steps 1 – 3 and call a qualified appliance technician. Write the number here: _____

_____ to investigate for sources of CO from fuel burning equipment and appliances, and inspect for proper operation of this equipment. If problems are identified during this inspection, have the equipment serviced immediately. Note any combustion equipment not checked by the service technician and contact the manufacturer directly for more information about CO safety and this equipment.

There are also alarms on your engine that could be sounding if the engine is running. Be sure and check your manufacturer’s documentation for information concerning these alarms.

13.1.2 Upon Boarding

If you detect fuel fumes, follow the procedures listed here and in the Fuel Chapter of this manual.

13.1.3 Strong Fuel Fumes

Fuel fumes are heavier than air and can collect in the bilge area. These fumes are extremely hazardous. If you detect strong fumes, proceed as follows:

⚠ WARNING ⚠

Leaking fuel is a fire and explosion hazard. Personal injury or death could occur.

⚠ DANGER ⚠

Explosive fuel vapors can become trapped in the lower portions of the boat. Close all hatch covers, windows, doors, and compartments while fueling your boat.

1. Evacuate all occupied enclosures immediately.
2. Shut down engines and generator.
3. Turn off all electrical circuits.
4. Inform the dockmaster. Have a qualified technician check the boat immediately to determine the source of the odor.
5. Open the boat for natural ventilation.
6. When you can no longer smell fumes, locate the source. Dispose of fuel in a safe, approved manner.

13.2 Starting the Engines

First, turn power at the battery switches to the On position, energizing the battery and switch panel (detailed in the DC Electric Chapter). Make sure that the bilge blower hoses are properly attached and that blower openings are not blocked.

It is important to follow the procedures to prevent electric shock.

Check that bilge pumps are working by switching breaker to MANUAL (OFF) position. Switch ON breaker for fresh water pump to make sure it is working.

Check out the following equipment and accessories:

- Seawater intakes that feed propulsion equipment
- Navigation Lights
- Throttle and shifter for smooth operation
- Steering system ease of operation

⚠ WARNING ⚠

Using a damaged or improper cord for shore power can cause electrical shock and serious injury. Use a cord specifically designed for shore power connection. Do not use a household extension cord.

⚠ CAUTION ⚠

Water is an excellent conductor of electricity. Keep shore power cord out of water. Do not operate any AC device while you, or the cord, are in the water. To prevent injury or equipment damage, keep all AC electric system components dry.

⚠ WARNING ⚠

DO NOT disconnect the shore power cord to the boat first. You could accidentally drop the cord into the water, which may result in electrical shock and serious personal injury.

Check engine, and gear box oil level. Refer to the engine manual for instructions. Add oil if needed.

Check the coolant level.

13.2.1 Running the Engines

Now it is time to start the engines. This is accomplished by the following procedures:

1. First, move the throttle to the idle position and ensure that the shift levers are in neutral.
2. Next, turn the switch to the "On" position. You will then hear an audible alarm. This is the oil alarm and will cease when the engines have started and the oil pressure rises. You can also check the voltage gauges to see if you actually have enough power in the batteries to start the engines.
3. After checking the DC gauges, then start the engine with the start switch.
4. Once the engine starts and the oil pressure builds, the alarm will cease. If the alarm does not cease, shut down the engines and check your oil levels. If normal, seek the help of a professional mechanic.

! WARNING !

In order to prevent premature starter failure, do not continuously crank engine starters for more than 10 seconds.

5. As the engines warm, the temp gauge will start to rise. Watch the gauge and make sure that the engines do not run hot.

6. Once the engines come up to operating temp (check manufacturer's recommendations for correct temperature), move the shift lever to Fwd and Reverse to make sure that the transmission will engage.

7. Now, shut down the engines and recheck your oil and transmission fluid levels.

! WARNING !

DO NOT remove cooling system filter cap when engine is hot. Allow to cool and then remove pressure cap slowly, allowing pressure to vent. Hot coolant under pressure may discharge violently.

! WARNING !

Exhaust gasses contain Carbon Monoxide. This is a poisonous gas and can cause death. Shut down engines immediately, if any exhaust leaks are detected.

Important: Always be careful when starting the engines. Use common sense and good judgment. Shut down the engines immediately if you observe any unsafe operating conditions.

Important: If engine fails to start within 10 seconds, release switch. Allow starter motor to cool for at least 60 seconds, then try starting the engine again.

Note: Should there be a problem with the battery voltage level, see the section in this chapter for emergency operation.

13.3 Getting Underway

! WARNING !

Before ever pulling away from the dock, make sure that the shore power cord and the fresh water hoses are disconnected.

Check that the fresh water tanks are full.

Verify that you have up to date fire extinguisher and flares.

Make sure you have the required safety equipment for your passengers.

After engines reach operating temperature, accelerate the engines to 2000 RPM's. Check that voltmeters read 13 to 14.5 volts.

Check wind, tide, and current to determine the best way to maneuver your boat away from the dock. Cast off mooring lines.

Shift your boat's engine into forward or reverse, depending on whether you want to move the bow or the stern away from the dock first. Your engines should be running at a slow speed as you move away from the dock.

Once your boat is in open water, you can safely accelerate to cruising speed. Advance throttle to setting which provides your desired engine speed (RPM's).

13.3.1 Getting Ready to Sail

Note: This is not intended to provide a complete guide on sailing! The 'art' of managing a sailboat in all weather, tidal and day/night conditions can not even be taught by reading even the best instruction book. If you are not proficient in handling sail boats please refrain from handling this boat and obtain professional training and certificates of which some might be required for you to navigate this boat in certain areas or countries.

The following is a simple guide only:

1. Install the battens in the mainsail and install the mainsail onto the boom from the forward end. Remove the stop pin or open the sail gate in the mast and install the luff slides into the track on the back of the spar. Reinstall the stop pin or close the sail gate to prevent the slides from falling back out again. Pack the sail into the sailpack lazyjack system on your boom or furl it into the mast care-

fully adjusting some tension on the sheet to keep the sail taught.

2. Install the out haul line in the boom with the messenger line provided and lead from the sheave at the back of the boom through the lower cringle at the back of the sail and aft to the end of the casting.

3. Install reefing lines in the boom with the messenger line provided and lead from the sheave through the relevant cringle at the back of the sail and then down to the sliding eye on the bottom of the boom. Pull enough slack into the reef line so that the sail can be fully raised unimpeded by the reef lines. Tie the mainsail onto the boom with the sail ties provided.

4. Install the jib sheet onto the jib and lead the sheets between the shrouds and aft to the traveling cart of jib track on side of the deck, then lead the jib sheet to stand-up turning block on toe-rail then tie it on furling winch for further operation. Tie figure eight knots in the end of the sheets to prevent them from running back through the turning block.

5. Raise and unfurl sails, beginning with the main and then the jib while powering into the wind. Once each halyard, is tensioned by the winch, the halyard can be pushed down into its respective rope clutches and the halyard removed from the winch, freeing the winch for the next halyard or sheet. However, care should be taken not to inadvertently open the rope clutches, since the sails will lower rapidly if this is done. When the sails are raised, the boat can be laid off and the engine turned off.

6. Once the main is sheeted in and you are sailing upwind, confirm the main topping lift position. The main should be capable of sheeting in hard without the topping lift being tight. With the main sheeted in hard, the topping lift should have eight to ten inches of sag and should be adjusted accordingly.

7. After a day of sailing, the sails should be lowered / furled in while again powering into the wind, with the jib furled in first and then by lowering the main. Protect your sails by covering them with the lazyjack sailcover or furling them completely up.

13.3.2 Tuning the B&R Rig

The easiest method for tuning the B&R rig is to perform step one as follows before the mast is stepped, with it lying aft side down on two sawhorses. Begin with all rigging slack. If the mast is already stepped, loosen all the

rigging, and then proceed to step one.

1. Start with all the rigging slack. Then induce the mast bend by tightening the reverse diagonals (diamonds). Measure the bend by tensioning the topping lift line or the main halyard between the masthead and the gooseneck. Mast pre-bend, the maximum amount of **depth of curvature (D)** occurred on middle height of the standard rig (non-furling mast) should be **around 0.5% of the length of "P" and do not exceed 2% of "P"**. Mast pre-bend, the maximum amount of **depth of curvature (D)** occurred on middle height of the furling rig (furling mast) should be **around 0.5% of the length of "P" and do not exceed 1.0% of "P"**. The alternative measurement can be done for determining the mast pre-bend. Measuring perpendicular from the aft face of the mast to the halyard at the deepest part of the bend. It can be less than that based on the sail shape and your own preference. The bend should also be evenly distributed along the mast to give a smooth shape. Keep in mind that bending a furling mast may make it more difficult to furl and will not do much to flatten the sail as in a standard rig. It is very important that the mast also be straight from side to side at this time. Tighten or loosen the diagonals to achieve this.

2. Step the mast with all shrouds attached but with the turnbuckles completely loosened (if the mast was not already stepped).

3. Attach the jib halyard to a cleat on the bow to support the mast in a raked position (the masthead should be about 2'-0" {60cm} behind the step). Attach the verticals and tighten them until you can just see the hole for the cotter pin in the turnbuckle. Tighten the jib halyard until you can attach the forestay. At this point, the masthead should be raked so that a weight hung on the main halyard hangs about 18" behind the mast step.

4. Use the main halyard to check that the mast is centered from side to side. Pull it tight and mark the halyard next to the verticals chainplate. Now do the same in the other side to see if the marks line up. If not, tighten and/or loosen the verticals until the marks line up. Once the masthead is centered, begin tightening the verticals. While tightening the verticals, you may notice the bend in the mast increasing. Now you can tighten the lowers then tighten D2, which will tend to straighten the lower part of the mast. Be sure to tighten port and starboard sides evenly.

5. Now you should tighten the headstay until it is approximately half closed as well. This should induce the approximate amount of headstay tension so the headstay

Hunter 50cc • Getting Underway

does not shack easily. Never use anything more than a pair of wrenches to tighten your rigging. If you use an extended piece of pipe on the handle of a wrench, you can over-tighten the rigging and do damage to the mast or rigging.

6. On the Hunter 50cc, it is necessary to go up the mast in a Bosun's Chair to tighten the number 2 diagonal shroud (D2 or intermediate shroud). Always use caution when "going aloft". You should always use a mountain climbing harness or Bosun's Chair intended for this use. Always tie into the harness with the halyard using a bowline and then secure the shackle as a back up as the knot is more reliable than a mechanical fastener. The person hoisting you aloft should keep the halyard stopper closed to prevent falls. Good communication between the two of you is also important. Tighten the D2 until it has just become tight ened then add two complete turns. While at the first spreader, look up the back of the mast to see if it is straight (rather than bent from side to side). If it is not straight then adjust the appropriate D2 and or RD2 to straighten it.

7. Have the person on deck carefully lower you. They should keep the halyard wrapped at least twice around the winch and should always have one hand able to stop the halyard from running free. Once on deck, look up the back of the mast and see if it is straight (rather than bent from side to side). If not, then adjust the lowers (D1) until it is.

8. The final test is to go sailing in 10-15 knots of wind. If, when sailing upwind, the shrouds on the leeward side are slack then tighten them to remove about half the slack keeping note of the number of turns. Then tack and do the same to the other side. Do this until you are happy with the tension and the leeward side does not get loose when the boat is heeled. Now, sight up the mast to be sure it is still relatively straight from side to side. If it is not then adjust to appropriate rigging to correct it. For example: If the mast is straight until the upper spreader and then hooks to the windward side, then you will have to revisit steps 6 and 7 above. Remember to always tighten the new leeward shroud, tack and tighten the new leeward shroud the same amount. This prevents damage to the turnbuckles and is also much easier to do. Keep in mind it is also possible to have something too tight such as a diagonal shroud.

9. At this point, you should have adequate headstay tension. The sails are built for an average of 14" (350mm) of headstay sag, possibly more or less, depending upon light or heavy air. The bend in the standard mast

should be about 1% (maximum) of "P" and 2" (50mm) (maximum) in the furling mast and it should be nearly straight from side to side when sailing upwind. If any of these are not true, then revisit the appropriate step above to correct it. If the sag in the headstay is too much then adding tension to the verticals will fix it.

10. Once the rig is tuned, you should make sure to add the cotter pins to all the rigging, bending back the ends and taping them to prevent snagged lines, sails, and fingers.

Remember that rigging, like everything else, can age. As it gets older, it may need to be replaced. The frequency for which this becomes necessary depends on the climate and conditions in which the boat is sailed. For example: If you sail in the Caribbean, it should be replaced every 2-3 years compared to every 10 years for the Great Lakes. You should consult a professional rigger for advice.

13.4 Returning to Port

After completing the day's cruise and mooring your boat, shut down the engine.

* Reduce engine speed to idle. Place transmission control in neutral. Allow engine to idle for a few minutes.

* Move switch to OFF to shut down the engine.

Before going ashore, check the following items:

- Shore power on and plugged in
- Battery charger operating
- Shaft and rudder log for leaks

A thorough washdown of your hull, decks, and rigging with soap and fresh water will help keep your boat looking like new for years.

Note: See the AC Electric section in this manual for information on connecting the shore power, and the Water Systems chapter for information on connecting the dockside water supply.

13.5 Emergency Operations

You should always understand and be prepared to engage in Emergency Operations aboard your boat. The sea is unforgiving in this area, and you can find yourself in very bad trouble in a very short time, even if you are

prepared.

Do not rely on this manual to educate you in all the emergency procedures aboard your boat.

Always insure that you, and all aboard know the outlines for emergency operations.

Here we will provide you with some of the basics for some of the situations you may encounter. You may also review the Boating Safety chapter, of this manual.

13.5.1 Low Battery Voltage

Should you find yourself in a position where the start battery has too low voltage to start the engine, it is still possible to start with parallel starting.

Parallel starting actually links power from the house battery to supply the engine with the low voltage.

To start an engine using parallel starting, simply hold down the parallel start button, while holding the parallel start button, pressure the start button for the engine.

If you find that you have too low voltage in both batteries, then it will be necessary for you to shut down the engines completely and start your generator, or connect to shore power to recharge your batteries. Be sure and turn on the battery charger.



Charging batteries produces gasses which can explode if ignited. Explosion can shatter battery. Battery acid can cause severe personal injury such as blindness. Keep flame, spark, and smoking materials away from batteries while charging. Charge in a well ventilated area.



Batteries contain Sulfuric Acid and can cause severe personal injury if mishandled. Avoid contact with eyes, skin, or clothing. In case of contact, flush with water at least 15 minutes. If swallowed, drink large quantities of water or Milk of Magnesia, beaten egg, or vegetable oil, and get medical attention immediately.

13.5.2 Fire

Your boat has a halon (or equivalent) fire extinguisher system which operates automatically to extinguish a fire in the engine compartment. The system has an indicator light on the helm. Moving the switch to NORMAL before starting the engines activates the light. Check this light every time you start the engines. It shows that the system is charged and ready to operate.

A loud sound (similar to that of small arms fire) followed by a “rushing” air sound indicates activation of the extinguisher. If the green indicator light goes out or if you hear the extinguisher discharging, proceed as follows:

- * Activating the automatic fire system will automatically shut down the engine and the generator.
- * Evacuate all occupied enclosures immediately. If practical, evacuate the boat.
- * Do not run the blowers.
- * Do not open the engine compartment. Allow the halon fire extinguisher to soak the compartment for at least fifteen minutes.



Flash fire erupting from the engine compartment can burn you. Opening the engine compartment will feed oxygen to the fire and cause the fire to flash back. Keep engine compartment closed for at least 15 minutes after fire extinguisher discharges.

- * Wait for hot metals and fuels to cool before inspecting for damage or cause of fire.
- * Open engine compartment slowly. Have approved portable fire extinguisher at hand and ready for use.

Do not breathe fumes or vapors caused by fire. HALON FUMES ARE TOXIC!



H U N T E R[®]

MARINE CORPORATION

AN EMPLOYEE OWNERSHIP COMPANY

We Go The Distance

Chapter 14

Maintenance

Hunter 50cc



Maintenance

(The information below is Hunter Marine's opinion and should not be considered complete or exact list of recommendations.)

You have made the investment to purchase your boat. Now is the time to take care of it. Here we will supply you with the knowledge to do just that.

We will separate this chapter into sections that deal with each part of your boat. The exterior, the interior, and the mechanical components. At the end of the chapter, we will offer you some maintenance tips and also give you a schedule of maintenance to be performed. Remember that any manufacturer's recommended maintenance schedules supersedes ours and their specific schedules or tasks should be performed.

14.1 Maintenance Materials

Following is a list of tools we recommend that you carry on board your yacht. Note that this list is the minimum required:

- Flashlight
- Vise grips (small and medium)
- Needle nose pliers
- Screw and nut driver set with ratchet handle
- Multi-bladed knife
- Set of screwdrivers (Phillips and flat blade, including "shorty" in both)
- Offset screwdriver
- Set of combination wrenches (box at one end, open end at the other)
- Extra batteries for flashlight
- Set of tubing wrenches
- Wire crimping and stripping tool
- Hacksaw

14.1.2 Recommended Maintenance Materials

We recommend that you carry the following on board your yacht:

- Plastic marine tape
- Instant glue
- Silicone rubber
- Electrical tape
- Two-part epoxy adhesive
- Engine oil

Spray lubricant

14.1.3 Recommended Spare Parts

We recommend that you carry the following spare parts on board your yacht:

- Engine oil (1 case) (Refer to engine manual).
- Antifreeze (5 gallons) (Refer to engine manual).
- Transmission fluid (4 quarts) (Refer to transmission manual)
- Oil filters (2)
- Coolant pump impeller and cover plate gaskets (2)
- Spare engine hoses and clamps (2)
- Electric fuses
- Fuel filters (4)
- Water hose or pipe for freshwater unions
- Pipe or hose unions
- Engine accessory belts (2 complete sets)
- Propeller and shaft (for extended cruises)

To keep the exterior of your boat in good condition, you should follow a periodic preventive maintenance program and practice good storage habits. In this section, are important suggestions that will help keep your boat in the best possible condition.

14.2 Exterior

14.2.1 Care and Maintenance During Summer Months

Before storing your boat, remove loose items such as cushions, towels, and similar items. Water trapped under these items can cause gelcoat discoloration and mildew.

After each use, rinse the entire boat with fresh water. If the boat has been used in brackish or salt water, use a mild soap during the washdown.

Covering your boat between uses will protect the finish from direct sunlight. Do not cover it with anything that will not allow moisture to evaporate, for example, sheet plastic.

14.2.2 Finish Protection

Waxing two or four times a year is recommended. If you are in a climate where you use your boat year round, wax your boat every three months. If you have a summer boating season, wax at the beginning of the season and before winter storage.

Waxing helps protect your boat from everyday elements. Use a wax recommended for fiberglass (gelcoat) finishes. Many automatic, over-the-counter waxes can be used. Check the product label for recommended surfaces and applications.

14.2.3 Color Fading and Yellowing

Darker colors are more prone to fading because they absorb more of the sun's ultraviolet rays. Whites and off-whites will yellow, usually on the deck rails. If the finish on your boat has started to fade or yellow, and waxing will not restore the finish, compounding with a fine grit compound and a low speed buffer may be necessary. An automotive, fine grit rubbing compound will work well in most cases.

* Follow the manufacturer's application instructions. Do not apply compound or wax in direct sunlight.

* Never place the buffer in such a manner that the pad touches the ground. The pad will pick up dirt which will cause deep scratches in the finish.

* After compounding, clean the surface with soap and water. Apply a good coat of wax.

14.2.3 Minor Scratches

If you have light surface scratches and rubbing compound does not remove them, wet sanding may be necessary.

** To wet sand:

* Clean the area with soap and water. During sanding, try to keep the area free of dust and dirt.

* Use a 500 or 600 grit wet and dry sandpaper. Use a sanding block. Sandpaper and sanding blocks can be purchased from automotive supply stores.

* When sanding, keep the surface wet. On dry surfaces, press a wet sponge above the sanding area. Always keep the sanding block flat on the surface. Never use the edge or corner. Doing so will make scratches that rubbing compound will not remove.

* After completing wet sanding, compound the sanded area with a fine grit rubbing compound. Use a low speed (1200 – 2800 rpm) buffer. Several applications of rubbing compound will have to be applied before all the scratches

are removed.

* Apply a good coat of wax.

14.2.4 Stains

You can remove stains using a cleaner specifically made for gelcoat surfaces. Any cleaner recommended for cultured marble or fiberglass tubs and sinks will work. Most of these cleaners can be purchased at a grocery store.

If a cleaner does not remove the stain, use a fine grit rubbing compound. By hand, apply a small amount of the compound to the stain area. Using a cotton cloth and medium pressure, rub the compound into the stained area. After the stain is removed, wash the area with soap and water and apply a good coat of wax.

14.2.5 Stainless Steel

Rinse the SS rails and SS hardware after cruising. Polish them periodically to prevent salt water corrosion.

** Follow these procedures to clean stainless steel:

* Wash with hot water and soap or detergent such as Bon Ami or other cleaner available commercially.

* Rinse with clear water after cleaning. Wipe dry with a clean, soft cloth to avoid water marks.

* If discolorations or deposits persist, use a non-scratching household cleanser or other polishing powder with a little water and a soft cloth.

Important: Do not use abrasive cleaning products, pads, steel wool, or steel brushes. These products will damage the finish.

* For stubborn deposits, use a plastic scouring pad or soft bristle brush with cleanser and water. Rub lightly in the direction of the polishing lines of the finish. Do not use too much pressure because the cleaner may mar the surface.

* Do not allow deposits to remain on the finish for long periods of time. Do not allow salt solutions, disinfectant, bleaches, or cleaning compounds to remain on the finish. Chemicals in many of these compounds may damage the rails or hardware. Rinse with soft water after every exposure and wipe dry with a clean, soft cloth.

14.2.6 Deck Hatches

Wax the rubber gaskets on all deck hatches with a car-

nauba wax to ensure gasket material does not stick to Plexiglass.

14.2.7 Acrylic and Plexiglass

Important: Do not use glass cleaning sprays, scouring compounds, or solvents (such as acetone, gasoline, or thinners) to clean acrylic or Plexiglass.

Following are guidelines for cleaning acrylic and Plexiglass parts:

- * Wash acrylic hatches, windows, and any other acrylic compounds with mild soap and plenty of lukewarm water.
- * Use a clean, soft cloth.
- * Apply only a light pressure when cleaning.
- * Rinse with clear water, and blot dry with a damp cloth or chamois.

14.2.8 Windows

The window frames on your boat are made of high quality aluminum with an enamel paint surface. The frames need no maintenance other than cleaning with soap and water. Do not use abrasive or strong chemicals. These may damage the finish and allow corrosion to start. Frames should be protected with marine wax.

The glass in the frames is tempered safety glass and requires only normal cleaning.

The side windows and deck hatches are made of acrylic plastic. Refer to instructions for cleaning acrylic and Plexiglass.

14.2.9 Caulking

All deck fitting, bow rails, windows, hatches, etc, have been caulked with the highest quality material to ensure a waterproof joint with the boat. However, normal use will flex the joint and eventually break down the seal.

Note: We recommend that all deck fittings, hatches, windows, rail, etc. be caulked periodically to prevent damaging leaks from developing.

14.2.10 Bottom Paint

We recommend an annual cleaning, sanding, and appli-

cation of anti-fouling paint. Some owners may have problems with paint failure because of unusually deep penetration of the parting compound used in molding the hull. This condition is unpredictable and is not covered by warranty. Usually cleaning and light sanding is all that is needed before recoating with a quality anti-fouling paint. Check with your boat dealer for recommendations about the specific paint to be used in your area.

Important: Do not paint the zinc anodes (connected to the boat's bonding system) on the outside of the transom.

14.3 Interior

You can usually clean the surfaces of these components with a mild cleaner such as Fantastic. Avoid using harsh or abrasive cleaners. Use approved marine sanitary treatment chemicals to control the odor in the toilet and holding tank.

14.3.2 Walls

The wood used in your boat is treated at the factory with a multi-coat finish process. To maintain the finish, use a good grade of furniture polish.

14.3.4 Bilges

The bilges are finished with a high quality gelcoat which is easy to keep clean. Several brands of bilge cleaners will dissolve dirt and grime, but will not harm the environment when pumped overboard. If you keep the bilge clean, it is much easier to identify leaks or other problems if they should develop.

Important: The Federal Water Pollution Control Act prohibits the discharge of oil or oily waste into or upon navigable waters in the United States. Violators are subject to a penalty.

14.3.5 Shower Sump

The showers drain into contained Sump which keep hair, soap, scum, and bacteria from building up in the bilge and developing an odor. The Sump consists of a plastic box, a pump, and an automatic float switch. A detailed instruction on cleaning the shower sump can be found in the Sanitary Systems Chapter 10. This describes the function more thoroughly.

Important: Periodically open the sump box and clean out the buildup of hair and scum to prevent eventual clogging of the pump.

14.4 Mechanical Systems and Components

Refer to the manuals supplied by the boat component manufacturers for their recommended periodic maintenance. The manuals may indicate maintenance requirement, in addition to, the minimum maintenance tasks listed in the following charts.

Note: In case of conflicts between the maintenance information in this manual and the manuals supplied by the equipment manufacturer, the equipment manuals take precedence.

14.4.1 Engine Oil

See engine operating manual for recommended oils and correct procedures for checking and replenishing oil.



Hot coolant under pressure may boil over and cause burns or other serious injury when cap is removed. Allow engine to cool. Open pressure cap slowly to allow pressure to vent before removing cap.

14.4.2 Engine Coolant

See engine operating manual for recommended coolants and correct procedures for checking and adding coolant.

14.4.3 Engine Exhaust

Visually inspect the engine and generator exhaust systems (hoses, joints, manifolds, etc.) for leaks. Make sure all clamps are tight. Check hoses and exhaust boxes for damage. Replace any damaged exhaust system component.

Note: Any discoloration around a joint or gasket usually indicates a leak.

14.4.4 Generator Oil

See generator operating manual for recommended oils and correct procedures for checking and replenishing oil.

14.4.5 Generator Coolant

Refer to the generator manual for detailed recommendations about checking and adding coolant.

14.4.6 Transmission Oil

Refer to the transmission manual for detailed recommendations about checking and adding oil.

14.4.7 Fuel Filter

Refer to the engine manual for correct information about checking and replacing the fuel filter on gasoline engines.

For diesel engines, check all fuel filters daily to remove all sediment and water from the filter. Inspect the canister for possible corrosion or deterioration. Replace canister if you observe any corrosion or other deterioration.

Replace the filter element at least once each season, more often if there is contamination of the fuel system. Always replace the bowl gasket each time the filter is reassembled. Check carefully for any signs of leakage.

14.4.8 Fuel Line Connections

Check all fuel line connections for leaks at least once a year. Tighten as necessary.

Important: Be careful when tightening fittings. Over-tightening can crack the flair fittings and flair nuts. Use only tube wrenches when tightening connections.

14.4.9 Batteries



Avoid spilling battery electrolyte into the engine compartment or bilge. Also, avoid getting saltwater on or in the battery. Either condition can create a gas that is explosive and poisonous if inhaled. If you spill electrolyte, ventilate the area. Neutralize the acid in the electrolyte with baking soda. Clean up neutralized electrolyte with a disposable rag or paper towel.

We recommend you use Gel type batteries.

Although these batteries are relatively maintenance free, some simple routine maintenance can increase the effectiveness and life.

* Keep the batteries fully charged. Batteries kept fully charged last longer than batteries kept at a partial charge.

* Check the level of the electrolyte regularly. Correct level is just above the plates. Add distilled water only if necessary. Over-filling can cause poor performance and early failure.

* Check the battery every 30 days. Keep the top of the battery clean. When necessary, clean the top of the battery with a baking soda solution and rinse with fresh water.

Important: To prevent battery failure, do not allow the soda solution to enter the battery cells.

* Inspect the cables and clamps regularly.

* Remove the battery cables and clean the battery terminals and posts regularly. Use a wire brush or bronze wool. After re-connecting the terminals, apply a coating of grease or petroleum jelly (Vaseline) to protect them against corrosion.

Important: Before cleaning the batteries, disconnect and remove them from the boat.

* Replace corroded or damaged parts immediately.

* Remove the batteries from the boat during periods of extended storage. Store the batteries in a cool (above freezing), dry area.

All batteries lose some charge during storage, but the loss of charge is inversely proportional to the temperature. The lower the temperature, the less charge is lost. Avoid storing the batteries in a humid area. Humidity will lead to corrosion of the terminals.

14.4.10 Shore Power Cable Care



Electrical shock can cause injury or death. Before working on electrical system, disconnect all power sources. Inform others to prevent accidental re-connection of electrical service. All voltages above 12 volts are dangerous. Maintaining power cable while connected to shore power can cause electrical shock. Disconnect cord before maintenance.

Clean the cable with a grease cutting household detergent. Apply a vinyl protector periodically.

The metallic parts of the cable are corrosion resistant.

You can, however, increase the life of the cable in a salt water environment by wiping the exposed parts with fresh water. Then, dry them and spray them with a moisture repellent.

If the cable is dropped into salt water, rinse the plug and connector end thoroughly in fresh water. Then shake or blow off excess water and allow cable to dry. Spray plug and connector with a moisture repellent before you use the cable again.

14.4.11 Electrical System Connections

At least once each year, disconnect electrical connectors in the bilge, engine, and upper control areas. Check the terminals for corrosive buildup. Have your boat dealer repair connectors and terminals if they are corroded.

14.5 Periodic Maintenance

Proper and timely maintenance is the best insurance you can buy for trouble free and pleasurable boating. Included in this section are maintenance charts which identify maintenance tasks and their frequency. Use the charts as a checklist.

Following are specific maintenance tasks that you should complete after the first 20 hours of operation:

- * Check rudder lip seal for leaks (no leaks at all).
- * Check propeller shaft packing glands for leaks (approximately 1 drop per minute).
- * Check all through hull fittings for leaks.
- * Check all doors and cabinets for proper fit and operation.
- * Realign propeller shaft
- * Tighten all engine mounts.
- * Complete engine maintenance as recommended by engine manufacturer.
- * Tighten all hose clamps and lubricate them.
- * Check and tighten all pressurized water system fittings.
- * Check and service batteries, tighten battery connections, and lubricate as needed.

At the end of this chapter, you will find a maintenance schedule. It is important that you keep the manufacturer's documentation for the components and follow the maintenance schedules and procedures listed in that literature. This information takes precedence over what is supplied by the boat manufacturer.

14.6 Storage and Lifting

In most cases, the reason for storage is winter layup. The information in this section is a general guide. Your boat dealer or a competent boatyard should prepare your boat for winter storage. If you are removing your boat from the water for another reason, use the information in this section as a guideline. Following the procedures in this section helps to extend the life of your boat and its equipment and simplifies re-commencing in the spring.

Indoor storage is beneficial if you are storing your boat in a climate that produces ice and snow. However, the storage building should be adequately ventilated, not tightly closed. Ventilation, both around and throughout the boat, is very important.

If you use outdoor storage facilities, cover your boat with a canvas cover with provisions for ventilation to keep the boat from "sweating." Building a frame over the boat to support the canvas will allow the passage of air around the boat. The frame should be a few inches wider than the boat so the canvas will clear the rails.

Before preparing your boat for winter storage, check the condition of the boat and its systems and equipment. Note any repairs needed. The need for other repairs may become apparent during winterization. Make arrangements to have the repairs completed.

14.6.1 Lifting Your Boat

Following are guidelines which will help prevent damage to your boat as it is being lifted.

- * Never hoist the boat with a greater than normal accumulation of water in the bilge. Fuel and water tanks should be empty.
- * Place slings where indicated by the sling tags on the gunwale. Proper location of the aft sling is critical. Lifting aft of the station indicated may damage the propeller shaft. Lifting forward of the station indicated, with the sling under the exhaust outlets, may cause cracking

which is not covered by the warranty. Blocks or pads at the chine corners will help keep pressure to a minimum at this point.

- * Disconnect the propeller shafts at the transmissions to prevent damage to the transmission.
- * Use flat, wide slings made of belting and spreader bars long enough to keep pressure off the gunwale. Do not use cable slings. Pressure by the slings on the gunwale can cause severe gelcoat crazing or more serious hull damage.
- * The spreader bar at each sling should be as long as the distance across the widest point the sling surrounds.
- * Weight should be primarily distributed along the keel. If a marine railway or platform is used, locate and adjust the blocking to distribute the weight over several areas at the intersection of stringers and bulkheads. The bunks and/or blocks should match deadrise angle and provide adequate support and stability.
- * When lifting the boat, keep the bow higher than the stern so the exhaust lines can drain. This will keep water from running forward through the manifold and into the engine itself where the water can become trapped.

Note: Keep the bow higher than the stern every time the boat is lifted. Do not lift the stern to change a propeller. Doing so can cause water to enter the engine. Engine failure is possible if water enters the engine cylinders. This water can cause hydrolock and bend the piston rods. Even a small amount of water can cause rust or other damage.

14.6.3 Draining Your Boat

Your boat has bilge pumps for draining water from the bilges. Some compartments in the bilge may not drain completely because of the position of the boat. Pump these compartments out then use a sponge to remove all remaining water.

Procedures for draining and winterizing the fresh water system are in this section under the "Preparing for Storage" heading.

14.6.2 Preparing for Storage

- * Clean, scrub, and sponge the hull and deck as soon as the boat is pulled from the water and is still in the sling. Cleaning marine growth from the hull is easier when it is

Hunter 50cc • Maintenance

still wet.

* Clean the inside of all hull openings, through hull fittings, and screens. Inspect the hull and underwater gear for signs of wear, deterioration, or damage. Note any damage to the propulsion equipment, helm area, cabin, etc. Make repairs, if at all possible, before covering your boat.

* Fill the fuel tanks with treated fuel to prevent condensation. If you use a stabilizer or conditioner, be sure to follow the instructions on the container.

Important: Do not overfill fuel tanks so fuel flows from the vent. Allow room in the tanks for fuel to expand.

** Prepare the Engines for Storage:

* In areas where temperatures fall below freezing, the bilge area under the engines must be pumped out and sponged completely dry. Check for areas that do not drain to the pumps. Drain mufflers.

Note: Refer to the engine owner's manual for winterization and storage procedures.

** Prepare the Batteries for Storage:

* Be sure main battery breakers are off.

* Remove batteries from boat and store in area where temperatures remain above freezing.

* Place batteries on a wooden pallet or bench.

* Keep batteries charged. Check electrolyte levels regularly. Add electrolyte if needed.

** Prepare Holding Tank

* Empty and rinse holding tank until tank is clean.

* Close head intake seacock and remove hose.

* Pour the nontoxic antifreeze into the head and keep flushing the head until the antifreeze reaches the holding tank.

* If your boat has a macerator discharge and the boat is removed from the water, run the macerator pump long enough for antifreeze to run through the pump and the lines.

* Remove drain plug from seacock while valve is closed. Allow line to drain. Replace drain plug.

** Prepare the Fresh Water System:

* Remove the fresh water supply by opening the hot and cold faucets in the galley for 10 minute intervals. Repeat until the fresh water tank is empty.

* Open all faucets: galley, shower, cockpit shower, etc.

* Drain the water heater. Disconnect lines from the engine heat exchanger (if equipped). Drain exchanger and lines.

* Remove hot and cold water lines and hook them together.

* Remove inlet hose from tank and insert it into a container of nontoxic antifreeze. Turn pump on. Starting at faucet furthest from pump, open all faucets until antifreeze flows out.

* Turn off pump and reconnect hose to water heater and pump.

* Remove seacock drain plugs to prevent damage from freezing. Close all seacocks.

** Prepare Interior of Boat for Storage:

* To keep mildew from forming, remove all items that will hold moisture (PFD's, towels, blankets, clothing, canvas, etc.).

* Make sure all garbage is removed.

* Scrub the inside of the boat. Clean cabinets, drawers, and cupboards. Allow cabin area to dry and air for at least one day if possible.

* Stand or prop up mattresses and cushions remaining on board to allow good air circulation around them. Hang life preserver and other equipment to prevent mildew.

* Remove any detachable and valuable equipment and electronics.

** Prepare Exterior of Boat for Storage:

* Sand the hull bottom and apply at least one coat of anti-fouling paint.

Note: This coat of paint must be applied during winterization or before the beginning of a new boating season. Check with your dealer for information about the paint you should use.

* Apply a coat of wax to the entire boat. Put rust inhibitor on all metal parts.

* Cover the boat with a tarpaulin or mooring cover. If the boat is stored outside, you may need to place supports under the cover to shore up pockets where rain or snow can collect.

14.6.3 Draining Your Boat

Your boat has bilge pumps for draining water from the bilges. Some compartments in the bilge may not drain completely because of the position of the boat. Pump these compartments out then use a sponge to remove all remaining water.

Procedures for draining and winterizing the fresh water system are in this section under the “Preparing for Storage” heading.

14.6.4 Supporting Your Boat During Storage

A cradle is the ideal support for your boat whenever it is not in the water. Properly designed and located, the cradle will support the boat under the main frames. Support at these points is essential for preventing damage to the hull.

If a cradle is not available, the boat may be supported on two or three timbers across a boat well or on another firm footing substantial enough to keep the boat level. The timbers and the foundation must be substantial enough to prevent any change in shape while supporting the boat during storage. The weight carried by the supports should be evenly divided, the keel should carry a share of it.

Store the boat with the bow up so any accumulation of moisture will run off.

14.7 Fitting out after Storage

If the hull was not painted during winterizing, sand and pain the hull bottom before removing the boat from its cradle.

Before launching your boat, do not load unneeded equipment, furniture, and personal items until the launch and

final checkout are complete.

14.7.1 Pre-Launch Checkout

** Before placing your boat in the water, check and perform the following:

* Check all anchor lines and gear and replace, if necessary.

* Check all through hull fittings to make sure they are clean. Make sure all drain plugs are installed. Check all strut and through hull hardware for damage and tightness. Repair or adjust as needed.

* Check propellers and propeller shafts for proper installation and tightness. Clean propeller and shafts. Check shaft play in strut bearing. Replace bearing if play is excessive.

* Check shaft alignment. Refer to the engine owner’s manual or check with your boat dealer for details.

* Clean battery terminal posts and cable terminals with a wire brush or bronze wool. Install batteries and attach cables. After cable posts are tightened down, coat posts with oil or Vaseline to keep out air and acid. Check all wiring connections and contacts for corrosion and tightness.

* Check all seacocks for easy operation. Check the condition of all hoses.

* Check operation of bilge pumps in manual and automatic modes. Check operation of shower sump pumps.

* Check all bilge blowers for proper operation.

* Check operation of all DC circuits.

* Launch your boat.

14.7.2 Post Launch Checkout

** After launching your boat, check the following:

* Check all sources of possible leaks from bow to stern. Make this check with boat fully in the water, but still in the slings!

* Check engines and generator following procedures described in equipment manuals.

* Check the entire exhaust system for the engines and the generator carefully. Make sure all exhaust systems are gastight. If exhaust opening was plugged or covered during storage, remove blockage.

The above products should be applied according to the manufactures printed instructions. For more information you may wish to visit their website at <http://www.yachtpaint.com/usa/> or call 800-468-7589 by email to Interluxtechnicalservice@internationalpaint.com.

14.8 Drive Shaft Thru Hull (Stuffing Box)

14.8.1 Maintenance:

The stuffing box keeps water from leaking around the shaft into the boat. The stuffing box has a sealed packing system with hose clamps secured in place. Water tubing run from the seal assembly to water injection tubing of the engine.

Make sure there is no sign of cracks or loosen fasteners. If cracks occurred on one of the water tubings, they are considered to be replaced by a qualified marine technician.

If fasteners are loosened, they are considered to be re-tightened to avoid possible of leaking issues.

NOTE: The size of hose clamps might varies from model to model. Some models use a packless sealing system. reflects the type of stuffing box used on this model.

Compatibility of product should be investigated if other brands or types of Epoxy Coatings are preferred by the boat owner or repair facility.

14.9 Cast Iron Keel Maintenance

14.9.1 Keel Maintenance for Cast Iron (where applicable)

The cast iron keel (upper section only on some models) was coated with an epoxy primer before leaving Hunter Marine. You will find that as with most items, particularly underwater gear, ongoing maintenance will probably be required during seasonal or routine haulouts.

The epoxy primer used on your boats Keel or upper section was manufactured by International Marine Coatings. The product numbers used are as Follows:

Intergrade 269 Epoxy Primer / Tie Coating
Color / EGZ088 – Red Base
Converter / Curing Agent – EGA 089

Hunter 50cc • Maintenance

Routine Maintenance					
Item	Daily	75hr	250hr	Yearly	
Diesel Engines					
Check Exhaust system for leaks	X	X	X	X	
Check for loose or damaged parts	X	X	X	X	
Check fuel system line for leaks	X	X	X	X	
Drain water and sediment from primary fuel filter	X	X	X	X	
Drain water from fuel separator				X	
Clean or replace air cleaner elements			X		
Check oil level	X	X	X	X	
Check oil and filters			X		
Check cooling system for leaks	X	X	X	X	
Check zinc anodes					
Tighten engine mounts				X	
Lubricate shifter cables				X	
Check prop shafts for alignment					
Transmissions					
Check transmission fluid level	X	X	X	X	
Underwater Gear					
Check rudder and shaft packing for leaks				X	
Check propeller for dents or gouges				X	
Miscellaneous					
Check automatic pumps for operation	X	X	X	X	
Check caulking on deck hardware				X	
Check electrical connections for corrosion				X	
Check bottom paint				X	
Wax deck to maintain sheen				X	
Item	Daily	75hr	250hr	Yearly	

Hunter 50cc • Maintenance

Check and service batteries				X	
Lubricate terminals				X	
Routine Maintenance					
Item	Daily	75hr	250hr	Yearly	
Tighten all pressurized water system fittings				X	
Item	Daily	25hr	75hr	250hr	Yearly
Miscellaneous					
Halon Fire Extinguishers	X	X	X	X	X
Check battery electrolyte level	X	X	X	X	X
Check raw water strainers (generator, AC unit)	X	X	X	X	X
Item	Daily	Month	6 mo.	Yearly	
Generator					
Inspect Generator	X				
Check oil level	X				
Check coolant level	X				
Check battery charging system		X			
Check antifreeze			X		
Check belt tension	X				
Check generator air outlets		X			
Clean generator assembly			X		
Change crankcase oil and filter		X			
Drain sediment from fuel filter		X			
Clean crankcase breather			X		
Change fuel filter			X		
Clean cooling system				X	
Check for fuel, oil, cooling, and exhaust leaks with set running. Visually check belts for evidence of slippage.					
On new generators, change after 35 hours of operation.					



H U N T E R[®]

MARINE CORPORATION

AN EMPLOYEE OWNERSHIP COMPANY

We Go The Distance

Chapter 15

Glossary

Hunter 50cc



A

Aback: describes a sail when the wind strikes it on the lee side.

Abaft: towards the boat's stern.

Abeam:

at right angles to the center-line of the boat.

Aft: at or near the stern.

Amidships: the center of the boat, athwartships and fore and aft.

Anti-fouling: a poisonous paint compound used to protect the underwater part of a hull from marine growths.

Apparent wind: The direction and speed of the wind felt by the crew. It is a combination of true wind and that created by the movement of the boat.

Astern: behind the boat; to go astern is to drive the boat in reverse.

Athwartships: at right angles to the fore and aft line of the boat.

B

Back: when a wind backs, it shifts anticlockwise.

Back a sail: to sheet it to windward so that the wind fills on the side that is normally to leeward.

Backstay: a stay that supports the mast from aft and prevents its forward movement.

Ballast: extra weight, usually lead or iron, placed low in the boat or externally on the keel to provide stability.

Ballast keel: a mass of ballast bolted to the keel to increase stability and prevent a keel boat from capsizing.

Batten: a light, flexible strip fed into a batten pocket at the leech of the sail to support the roach.

Beam: 1, the maximum breadth of a boat; 2, a transverse member that supports the deck; 3, on the beam means that an object is at right angles to the centerline.

Bear away: to steer the boat away from the wind.

the direction of an object from an observer, measured in degrees true or magnetic.

Beat: to sail a zigzag course towards the wind, close-hauled on alternate tacks.

Belay: to make fast a rope around a cleat, usually with a figure-of-eight knot.

Bend: 1, to secure a sail to a spar before hoisting; 2, to moor a boat; 3, a sleeping place on board.

Bight: a bend or loop in a rope.

Bilge: the lower, round part inside the hull where the water collects.

Block: a pulley in a wooden or plastic case, consisting of a sheave around which a rope runs. It is used to change the direction of pull.

Boot-topping: a narrow colored stripe painted between the bottom paint and the topside enamel.

Bottlescrew: see Rigging screw.

Broach: when a boat running downwind slews broadside to the wind and heels dangerously. It is caused by heavy following seas or helmsman's error.

Broad reach: the point of sailing between a beam reach and a run, when the wind blows over a quarter.

Bulkhead: a partition wall in a boat normally fitted athwartships

C

Caulk: to make the seams between wooden planks watertight by filling with cotton, oakum or a compound.

Cavitation: the formation of a vacuum around a propeller, causing a loss in efficiency.

Center-board: a board lowered through a slot in the keel to reduce leeway.

Center-line: center of the boat in a fore and aft line.

Center of effort (COE): the point at which all the forces acting on the sails are concentrated.

Center of lateral resistance (CLR): the underwater center of pressure about which a boat pivots when changing course.

Chain pawl: a short lug which drops into a toothed rack to prevent the anchor chain running back.

Chain plate: a metal plate bolted to the boat to which the shrouds or backstays are attached.

Chart datum: reference level on a chart below which the tide is unlikely to fall. Soundings are given below chart datum. The datum level varies according to country and area.

Chine: the line where the bottom of the hull meets the side at an angle.

Cleat: a wooden, metal or plastic fitting around which rope is secured.

Clevis pin: a locking pin through which a split ring is passed to prevent accidental withdraw.

Clew: the after, lower center of a sail where the foot and leech meet.

Close-hauled: the point of sailing closest to the wind; see also beat.

Close reach: the point of sailing between close-hauled and a beam reach, when the wind blows forward of the beam.

Close-winded: describes a boat able to sail very close to the wind.

Coaming: the raised structure surrounding a hatch, cockpit, etc., which prevents water entering.

Cotter pin: soft, metal pin folded back on itself to form an eye.

Course: the direction in which a vessel is steered, usually given in degrees; true, magnetic or compass.

Cringle: 1, a rope loop, found at either end of a line of reef points; 2, an eye in a sail.

D

Dead run: running with the wind blowing exactly aft, in line with the center-line.

Deviation: the difference between the direction indicated by the compass needle and the magnetic meridian; caused by object aboard.

Displacement: 1, the weight of water displaced by a boat is equal to the weight of the boat; 2, a displacement hull is one that displaces its own weight in water and is only supported by buoyancy, as opposed to a planning hull which can exceed its hull, or displacement, speed.

Downhaul: a rope fitted to pull down a sail or spar.

Draft: the vertical distance from the waterline to the lowest point of the keel.

Drag: 1, an anchor drags when it fails to hold; 2, the force of wind on the sails, or water on the hull, which impedes the boat's progress.

Drift: 1, to float with the current or wind; 2, US the speed of a current (rate UK); 3, UK: the distance a boat is carried by a current in a given time.

Drogue: a sea anchor put over the stern of a boat or life raft to retard drift.

Drop keel: a retractable keel which can be drawn into the hull, when entering shallow waters and recovering on to a trailer.

E

Eye of the wind: direction from which the true wind blows.

F

Fair: well-faired line or surface is smoother with no bumps, hollows or abrupt changes in directions.

Fairlead: a fitting through which a line is run to alter the lead of the line.

Fathom: the measurement used for depths of water and lengths of rope. 1 fathom = 6 ft. or 1.83m.

Fid: a tapered tool used for splicing heavy rope and for sail-making, often hollow.

Fiddle: a raised border for a cabin table, chart table etc., to prevent objects falling off when the boat heels.

Fix: the position of the vessel as plotted from two or more position lines.

Forestay: the foremost stay, running from the masthead to the stemhead, to which the headsail is hanked.

Freeboard: vertical distance between the waterline and the top of the deck.

G

Genoa: a large headsail, in various sizes, which overlaps the mainsail and is hoisted in light to fresh winds on all points of sailing.

Gimbals: two concentric rings, pivoted at right angles, which keeps objects horizontal despite the boat's motion, e. g. compass and cooker.

Go about: to turn the boat through the eye of the wind to change tack.

Gooseneck: the fitting attaching the boom to the mast, allowing it to move in all directions.

Goosewing: to boom-out the headsail to windward on a run by using a whisker pole to hold the sail on the opposite side to the mainsail.

Ground tackle: general term used for anchoring gear.

Guard rail: a metal rail fitted around the boat to prevent the crew falling overboard.

Gudgeon: a rudder fitting. It is the eye into which the pintle fits.

Guy: a steadying rope for a spar; a spinnaker guy controls the fore and aft position of the spinnaker pole; the foreguy holds the spinnaker pole forward and down.

Gybe: to change from one tack to another by turning the stern through the wind.

H

Halyard: rope used to hoist and lower sails.

Hank: fitting used to attach the luff of a sail to a stay.

Hatch: an opening in the deck giving access to the interior.

Hawes pipe: see Navel pipe.

Head-topwind: when the bows are pointing right into the wind.

Headfoil: a streamlined surround to a forestay, with a groove into which a headsail luff slides.

Heads: the toilet.

Headway: the forward movement of a boat through the water.

Heave-to: to back the jib and lash the tiller to leeward; used in heavy weather to encourage the boat to lie quietly and to reduce headway.

Heaving line: a light line suitable for throwing ashore.

Heel: to lean over to one side.

I

Isobars: lines on a weather map joining places of equal atmospheric pressure.

J

Jackstay: a line running fore and aft, on both sides of the boat, to which safety harnesses are clipped.

Jury: a temporary device to replace lost or damaged gear.

K

Keel: the main backbone of the boat to which a ballast keel is bolted or through which the centerboard passes.

Kicking strap: a line used to pull the boom down, to keep it horizontal, particularly on a reach or run.

L

Lanyard: a short line attached to one object, such as a knife, with which it is secured to another.

Leech: 1, the after edge of a triangle sail; 2, both side edges of a square sail.
Leehelm: the tendency of a boat to bear away from the wind.
Lee shore: a shore on to which the wind blows.
Leeward: away from the wind; the direction to which the wind blows.
Leeway: the sideways movement of a boat off its course as a result of the wind blowing on one side of the sails.
Lifeline: a wire or rope rigged around the deck to prevent the crew falling overboard.
Limber holes: gaps left at the lower end of frames above the keel to allow water to drain to the lowest point of the bilges.
List: a boat's more or less permanent lean to one side, owing to the improper distribution of weight, e.g., ballast or water.
Log: 1, an instrument for measuring a boat's speed and distance traveled through the water; 2, to record in a book the details of a voyage, usually distances covered and weather.
Luff: the forward edge of a sail. To luff up is to turn a boat's head right into the wind.
Luff groove: a groove in a wooden or metal spar into which the luff of a headsail is fed.
Lurch: the sudden roll of a boat.

M

Marlin spike: a pointed steel or wooden spike used to open up the strands of rope or wire then splicing.
Mast Step: the socket in which the base of the mast is located.
Measured mile: a distance of one nautical mile measured between buoys or transits/ranges ashore, and marked on the chart.
Member: a part of the skeleton of the hull, such as a stringer laminated into fiberglass hull to strengthen it.
Meridian: an imaginary line encircling the Earth that passes through the poles and cuts at right angles through the Equator. All lines of longitude are meridians.
Mizzen: 1, the shorter, after-mast on a ketch or yawl; 2, the fore and aft sail set on this mast.

N

Navel pipe: a metal pipe in the foredeck through which the anchor chain passes to the locker below.
Noon Sight: a vessel's latitude can be found, using a sextant, when a heavenly body on the observer's meridian is at its greatest altitude. The sight of the sun at noon is the one most frequently taken.

O

Off the wind: with the sheets slacked off, not close-hauled.

On the wind: close-hauled.
Out haul: a rope used to pull out the foot of a sail.
Overall length (OAL): the boat's extreme length, measured from the foremost part of the bow to the aftermost part of the stern, excluding bowsprit, self-steering gear etc.

P

Painter: the bow line by which a dinghy, or tender, is towed or made fast.
Pintle: a rudder fitting with a long pin that fits into the gudgeon to form a hinged pivot for the rudder.
Pitch: 1, the up and down motion of the bows of a boat plunging over the waves; 2, the angle of the propeller blades.
Point of sailing: the different angles from which a boat may sail; the boat's course relative to the direction of the wind.
Port: the left-hand side of the boat, looking forward (opp. of starboard).
Port tack: a boat is on a port tack when the wind strikes the port side first and the mainsail is out to starboard. A boat on the port tack gives way to a boat on a starboard tack.
Position line/ Line of position: a line drawn on a chart, as a result of taking a bearing, along which the boat's position must be, i.e. two position lines give a fix.
Pulpit: a metal guard rail fitted at the bows of a boat to provide safety for the crew.
Pushpit: a metal guard rail fitted at the stern.

Q

Quarter: the portion of the boat midway between the stern and the beam; on the quarter means about 45 degrees abaft the beam.

R

Rake: the fore and aft deviation from the perpendicular of a mast or other feature of a boat.
Range: 1, see transit; 2, of tides, the difference between the high and low water levels of a tide; 3, the distance at which a light can be seen.
Rating: a method of measuring certain dimensions of a yacht to enable it to take part in handicap races.
Reach: to sail with the wind approximately on the beam; all sailing points between running and close-hauled.
Reef: to reduce the sail area by folding or rolling surplus material on the boom or forestay.
Reefing pennant: strong line with which the luff or leech cringle is pulled down to the boom when reefing.
Rhumb line: a line cutting all meridians at the same angle; the course followed by a boat sailing in a fixed direction.
Riding light to anchor light: an all-around white light, usually hoisted on the forestay, to show that a boat

under 50 ft. (15m.) is at anchor. It must be visible for 2 mls. (3 km.).

Rigging screw: a deck fitting with which the tensions of standing rigging, e.g. stays, shrouds, etc. are adjusted.

Roach: the curved part of the leech of a sail that extends beyond the direct line from head to clew.

Run: to run with the wind aft and with the sheets eased well out.

Running rigging: all the moving lines, such as sheets and halyards, used in the setting and trimming of sails.

S

Scope: the length of rope or cable paid out when making anchoring.

Scuppers: 1, holes in the toe rail that allow water to drain off the deck; 2, drain cockpit through hull.

Seacock: a valve that shuts off an underwater inlet or outlet passing through the hull.

Seize: to bind two ropes together, or a rope to a spar, with a light line.

Serve: to cover and protect a splice or part of a rope with twine bound tightly against the lay.

Serving mallet: tool with a grooved head, used when serving a rope to keep the twine at a constant and high tension.

Set: 1, to hoist a sail; 2, the way in which the sails fit; 3, the direction of tidal current or steam.

Shackle: a metal link with a removable bolt across the end; of various shapes: D, U.

Sheave: a grooved wheel in a block or spar for a rope to run on.

Sheet: the rope attached to the clew of a sail or to the boom, enabling it to be controlled or trimmed.

Shrouds: ropes or wires, usually in pairs, led from the mast to the chain plates at deck level to prevent the mast falling sideways; part of the standing rigging.

Sloop: a single-masted sailing boat with a mainsail and one head sail.

Spar: a general term for any wooden or metal pole, e.g., mast or boom, used to carry or give shape to sails.

Spindrift: spray blown along the surface of the sea.

Spinnaker: a large, light, balloon shaped sail set when reaching or running.

Splice: to join ropes or wire by unlaying the strands and interweaving them.

Split pin: see cotter pin.

Spreaders: horizontal struts attached to the mast, which extend to the shrouds and help to support the mast.

Stall: a sail stalls when the airflow over it breaks up, causing the boat to lose way.

Stanchion: upright metal post bolted to the deck to support guardrails or lifelines.

Standing part: the part of a line not used when making

a knot; the part of a rope that is made fast, or around which the knot is tied.

Standing rigging: the shrouds and stays that are permanently set up and support the mast.

Starboard: right-hand side of a boat looking forward (opp. of port).

Starboard tack: a boat is on the starboard tack when the wind strikes the starboard side first and the boom is out to the port.

Stay: wire or rope which supports the mast in a fore and aft direction; part of the standing rigging.

Steerage way: a boat has steerage way when it has sufficient speed to allow it to be steered, or to answer the helm.

Stem: the timber at the bow, from the keel upward, to which the planking is attached.

Sternway: the backward, stern-first movement of a boat.

Stringer: a fore and aft member, fitted to strengthen the frames.

T

Tack: 1, the lower forward corner of a sail; 2, to turn the boat through the wind so that it blows on the opposite sides of the sails.

Tacking: working to windward by sailing close-hauled on alternate courses so that the wind is first on one side of the boat, then on the other.

Tack pennant: a length of wire with an eye in each end, used to raise the tack of a headsail some distance off the deck.

Tackle: a purchase system comprising of rope and blocks that is used to gain mechanical advantage.

Tang: a strong metal fitting by which standing rigging is attached to the mast or other spar.

Tender of dinghy: a small boat used to ferry stores and people to a yacht.

Terminal fitting: fitting at the end of a wire rope by which a shroud or stay can be attached to the mast, a tang or a rigging screw/ turnbuckle.

Tide: the vertical rise and fall of the oceans caused by the gravitational attraction of the moon.

Toe rail: a low strip of metal or molding running around the edge of the deck.

Topping lift: a line from the masthead to a spar, normally the boom, which is used to raise it.

Topsides: the part of a boat's hull that is above the waterline.

Track: 1, the course a boat has made good; 2, a fitting on the mast or boom into which the slides on a sail fit; 3, a fitting along which a traveller runs, used to alter the angle of the sheets.

Transit: two fixed objects are in transit when seen in

line; two transit give position fix.

Traveller: 1, a ring or hoop that can be hauled along a spar; 2, a fitting that slides in a track and is used to alter the angle of the sheets.

Trim: 1, to adjust the angle of the sails, by means of sheets, so that they work most efficiently; 2, to adjust the boat's load, and thus the fore and aft angle at which it floats.

True wind: the direction and speed of the wind felt when stationary, at anchor or on land.

Turnbuckle: see Rigging screw.

U

Under way: a boat is under way when it is not made fast to shore, at anchor or aground.

Uphaul: a line used to raise something vertically, e.g., the spinnaker pole.

V

Veer: 1, the wind veers when it shifts in clockwise direction; 2, to pay out anchor cable or rope in a gradual, controlled way.

W

Wake: the disturbed water left astern of a boat.

Waterline: the line along the hull at which a boat floats.

Waterline length (WL): the length of a boat from stem to stern at the waterline. It governs the maximum speed of displacement hull and effects a boats rating.

Weather helm: (opp. of lee helm).

Weather side: the side of a boat on which the wind is blowing.

Wetted surface: the area of the hull under water.

Whisker pole: a light pole used to hold out the clew of a headsail when running.

Winch: a mechanical device, consisting usually of a metal drum turned by a handle, around which a line is wound to give the crew more purchasing power when hauling taut a line, e.g. a jib sheet.

Windage: those parts of a boat that increase drag, e.g., rigging, spars, crew, etc.

Windlass: a winch with a horizontal shaft and a vertical handle, used to haul up the anchor chain.

Windward: the direction from which the wind blows; towards the wind (opp. of leeward).

Y

Yawl: a two masted boat with a mizzen stepped aft of the rudder stock/ post.