

WWW.DIYSAIOR.COM

## How to service your Lewmar winch 1981

 **LEWMAR**

Lewmar winches are known world wide for their quality, technical innovation and performance. They have been tested to their limits by our engineers in the laboratory and by racing crews in their search for victory. They have given years of outstanding service to many thousands of yachtsmen to whom the ultimate performance of a yacht or its equipment is perhaps not so important as the pure joy of sailing a fine craft equipped with the best yacht hardware.

This booklet tells you how to give your Lewmar winches the care and attention they need to ensure that whether you sail for results, records or just pleasure, your winches will contribute that extra level of performance that is designed into each Lewmar winch.

#### **Frequency of Servicing**

Lewmar winches, like any other precision engineered product, must be serviced regularly as follows:—

1. **MONTHLY:** All Lewmar sheet winches should be lightly oiled and greased as shown.

2. **TWO OR THREE TIMES DURING ACTIVE SAILING SEASON:** All Lewmar winches should be stripped, cleaned and re-lubricated.

### **Lewmar Guarantee**

Lewmar winches have been developed over many years by extensive testing aboard the world's finest ocean racers, long distance cruising yachts and match racing yachts such as 12 metres. They are manufactured to quality standards in excess of those required by Lloyds and only the finest materials are used.

If installed, used and maintained as described in this leaflet, they will give outstanding performance.

Lewmar undertake that any winch which proves defective in materials or workmanship within 1 year of the date of supply will be repaired or replaced **FREE OF CHARGE** provided that the winch is returned by the registered owner to the nearest Lewmar office or distributor for examination. Lewmar reserve all rights on determining the nature of the alleged fault and their decision is final.

3. **AT THE END OF EACH SAILING SEASON AND BEFORE STARTING THE NEW SAILING SEASON:** All Lewmar winches should be completely stripped, cleaned, thoroughly checked for damage and lubricated using the full maintenance manual.

#### **General External Cleaning of Drum**

**Chromed Winches** — Wash drum regularly with fresh water and dry with chamois leather.

**OCCASIONALLY** use non abrasive liquid chrome cleaner to remove dirt deposits.

**Anodised Aluminium Winches** — Wash drum regularly with fresh water and dry with chamois leather. **DO NOT USE POLISHES OR ABRASIVES.**

**Stainless Steel Winches** — Wash drum regularly with fresh water and dry with chamois leather.

**OCCASIONALLY** use non abrasive liquid cleaner to remove dirt deposits.

This leaflet illustrates the service details of the current range of Lewmar winches.

The overall servicing principles may be used for earlier versions although the detailed construction of the winches may be different.

Lloyd's Certificate.  
Lloyd's made a very careful examination of the material, design, construction, quality control and test procedures used by Lewmar and approved all the existing systems without alterations. Lewmar's existing standards proved to be higher than were required by Lloyd's.



# Single Speed 6, 7, 8, 10 Servicing

1



Remove the circlip with a small screwdriver or knife blade.

2



Lift off the drum.

3

Nos. 6, 7



Wash centre stem and drum base with kerosene (paraffin). Dry with a non-fluffy cloth.

4

Nos. 8, 10



Wash centre stem, roller bearings and drum bore with kerosene (paraffin). Dry with a non-fluffy cloth.

5

Nos. 6, 7, 8, 10



Lightly oil the upper and lower pawls.

6

Nos. 6, 7, 8, 10



Remove centre spindle key, slide out spindle and grease lightly.

7  
Nos. 6, 7



Lightly grease centre stem.

8  
Nos. 8, 10

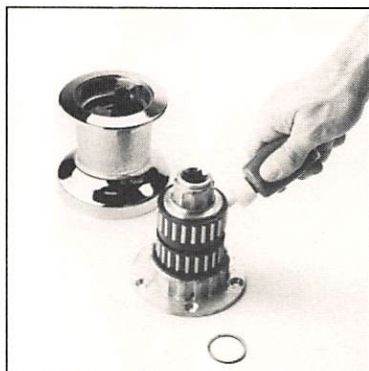

Lightly grease roller bearings.

Reassemble winch in reverse sequence to above. Check for correct operation.

## Two Speed 16, 24, 30, 40, 42 Servicing

1



Remove the top circlip with a small screwdriver or knife blade.

2

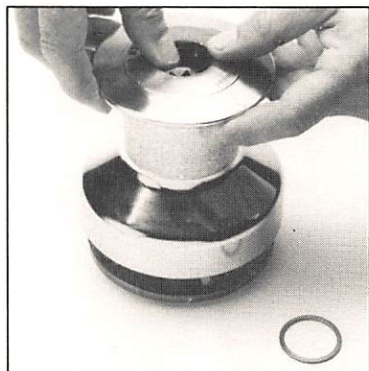

Lift off the drum.

3

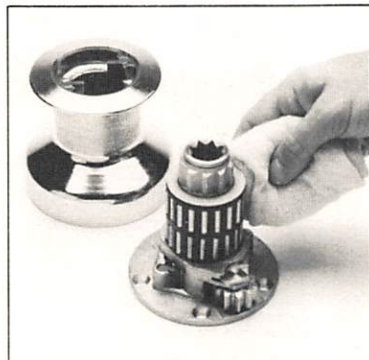

Wash centre stem, roller bearings and drum bore with kerosene (paraffin). Dry with a non-fluffy cloth.

4



Lightly oil top pawls.

5



Remove centre spindle key and slide out spindle.

6

No. 16



Clean spindle, grease lightly and oil pawls.

7

Nos. 24, 30  
40, 42

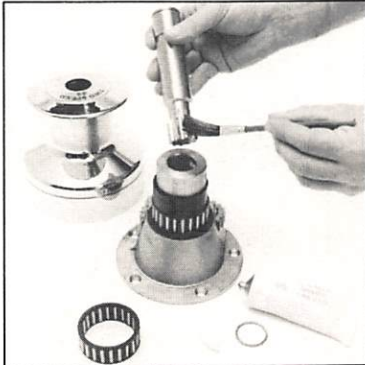

Clean and lightly grease spindle.

8

No. 16

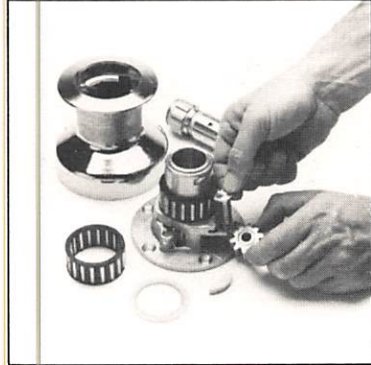

Remove gear, clean and lightly grease.

9

Nos. 24, 30,  
40, 42



Remove pawl gears and clean. Lightly oil pawls and grease gears.

10

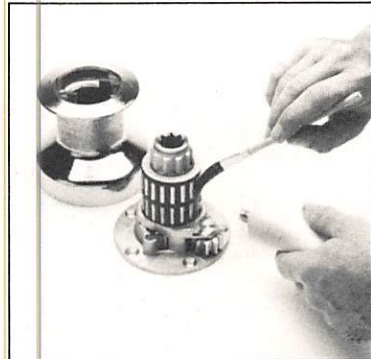

Reassemble spindle and gears. Lightly grease bearings. Oil pawls in winch base (16 only).

# Three Speed 44, 48, 55, 65 Servicing

1



Remove the top circlip with a small screwdriver or knife blade.

2



Lift off the drum.

3

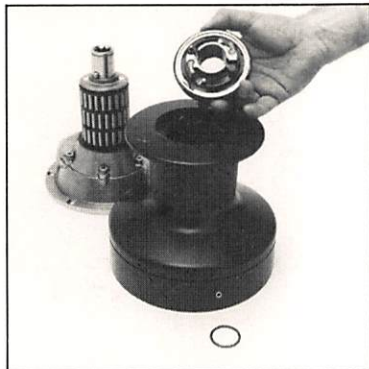

Remove the top cap assembly.

4

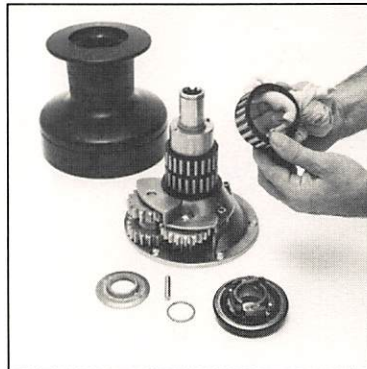

Wash centre stem, roller bearings, lower gears and drum bore with kerosene (paraffin). Dry with a non-fluffy cloth.

5

Nos. 44, 48

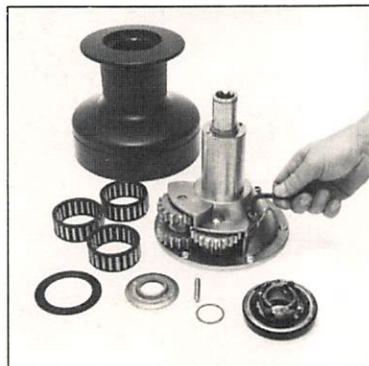

Remove socket head screws from centre stem with a  $\frac{1}{17}$ " AF allen key.

6

Nos. 44, 48



Remove top of centre stem complete with spindle.

7  
Nos. 44, 48



Remove spindle, lightly oil pawls and grease gear.

8  
Nos. 44, 48

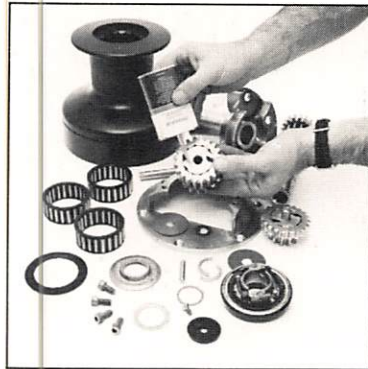

Remove pawl gears and clean. Lightly oil pawls and grease gears.

9  
Nos. 44, 48

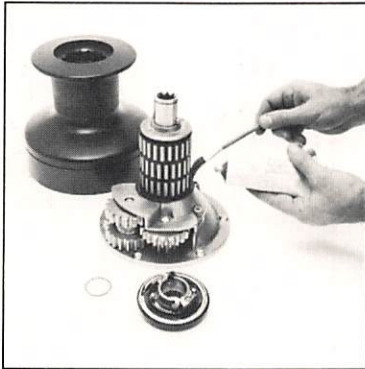

Reassemble, lightly grease roller bearings, output gear and gear teeth on winch drum.

10  
Nos. 44, 48

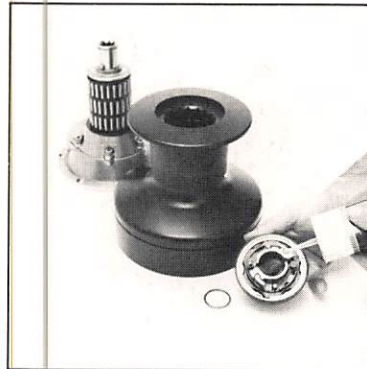

Wash top cap in fresh water to remove salt deposits. Lightly oil pawls and change grease mechanism. Check pawls operate freely.

11  
Nos. 55, 65



Wash top cap in fresh water to remove salt deposits. Lightly oil pawls and change grease mechanism. Check pawls operate freely.

12  
Nos. 55, 65

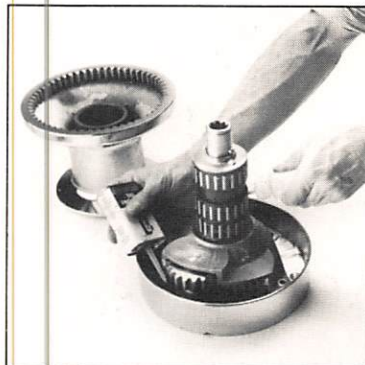

Lightly grease the roller bearings, gear teeth. Oil the ratchet assembly.

Reassemble winch in reverse sequence to above. Check for correct operation.

# Halliard Nos. 1, 2, 2×2, 3 Servicing

1  
No. 1



Remove the halliard, releasing the bitter end by unscrewing the  $2 \times \frac{1}{4}$ " UNC grub screws as shown.

2  
No. 1



Remove the top circlip with a small screwdriver or knife blade.

3  
No. 1

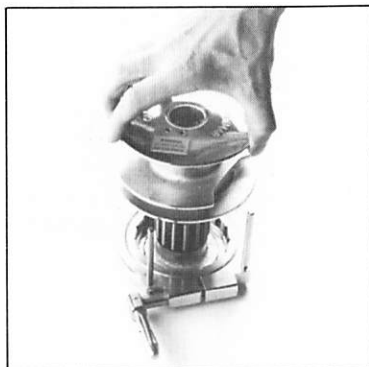

Lift off the drum.

4  
No. 1



Wash centre stem, roller bearings, lower gears and drum bore with kerosene (paraffin). Dry with a non-fluffy cloth.

5  
No. 1



Lightly oil the pawls.

6  
No. 1

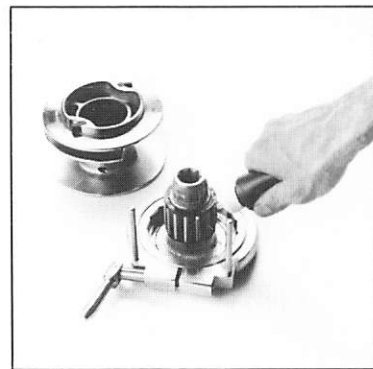

Lightly grease roller bearings.



7  
No. 1



Clean brake band and ratchet ring with light abrasive and wash with kerosene (paraffin). Dry with a non-fluffy cloth.

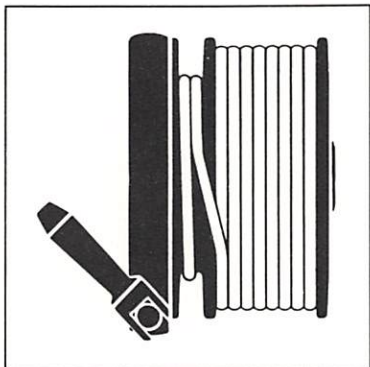

**Primary and secondary drums** — The main body of the halliard is stored on the primary drum and the turns should be stacked evenly as shown in the diagram. When the sail is nearly fully hoisted i.e. within 2 or 3 feet of the black band the final turns should be wound on the secondary drum to avoid crushing the wire.

Reassemble winch in reverse sequence to above. Check for correct operation.

8  
Nos. 2, 2 × 2, 3

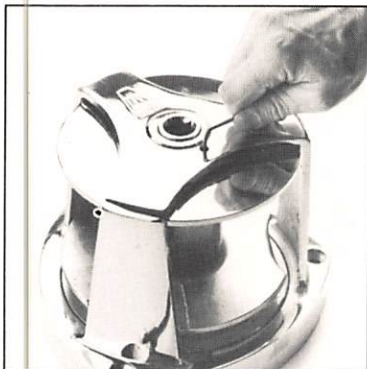

Remove the halliard releasing the bitter end by unscrewing the 2 grub screws ( $2 \times \frac{1}{4}$ " UNC—No. 2 and 2,  $2 \times \frac{1}{4}$ " BSF—No. 3). Turn the drum to locate the screws under the drum cage.

**NO OIL OR GREASE MUST BE APPLIED TO THE BRAKE MECHANISM OR ON ANY HALLIARD WINCH.**

**WINCH NOS. 2, 2 × 2 AND 3 — SERVICING SHOULD BE CARRIED OUT BY A LEWMAR SERVICE ENGINEER.**

**Warning:**

The brake should be tightened firmly before hoisting the sail. When lowering the sail the brake is released as described and the rate of descent controlled with the brake lever.

**THE HANDLE MUST NOT BE LEFT IN THE WINCH WHEN THE BRAKE IS RELEASED AS IT WILL REVOLVE. THIS IS DANGEROUS AND CAN CAUSE INJURY.**

# Holdfast Self-Tailing 16ST, 30ST, 34ST

## Installation and Operation

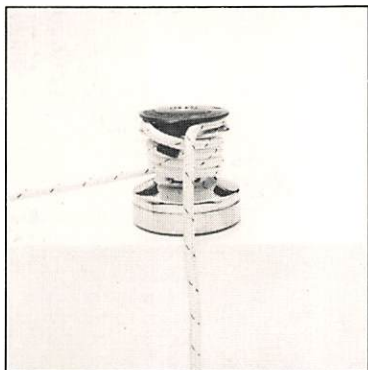

1. The rope must be placed in the jaws correctly. The turn leading from the drum must be passed across the stripper mechanism as shown and placed into the jaws.

2. The winch must be mounted so that the loose sheet falls correctly into a secure stowage position.

3. There must be a minimum of 3 turns of rope on the barrel.



To position installation on boat remove drum as above and refit top cap. Place winch so that stripper arm is in correct position and mark off for drilling.

# Holdfast Self-Tailing 16ST, 30ST, 34ST Adjustment

No. 16ST

With white washer in drum top –  
rope diameter 8 – 10 mm

With red washer in drum top –  
rope diameter 12 – 14 mm.

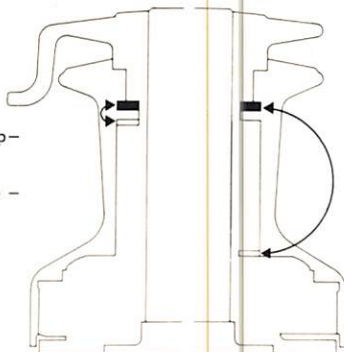

No. 30ST

With white washer in drum top –  
rope diameter 8 – 10 mm

With red washer in drum top –  
rope diameter 12 – 14 mm

No. 34ST

With white washer in drum top –  
rope diameter 10 – 12 mm

With red washer in drum top –  
rope diameter 14 – 16 mm

THE WINCH MUST BE ADJUSTED TO DEAL WITH DIFFERENT ROPE SIZES.

1

No. 16ST

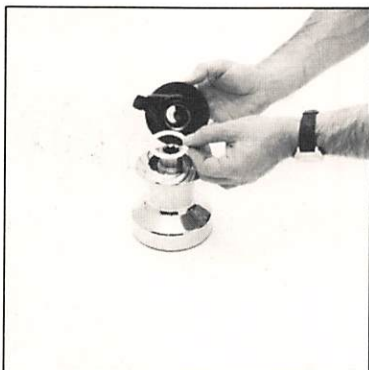

Remove top cap

2

No. 16ST

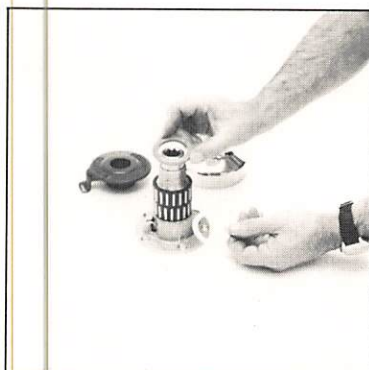

Exchange washer in drum top with centre  
stem washer **on top** of bearings.

3

Nos. 30ST,  
34ST



Remove top cap

4

Nos. 30ST,  
34ST



Exchange washer in drum top with centre  
stem washer **below** bearings.

# Holdfast Self-Tailing 16ST, 30ST, 34ST Servicing

1



Using a soft faced mallet or wooden block and hammer, loosen the top with a firm tap.

2



Unscrew top cap.

3



Lift off the drum.

4



Wash centre stem, roller bearings and drum bore with kerosene (paraffin). Dry with a non-fluffy cloth.

5

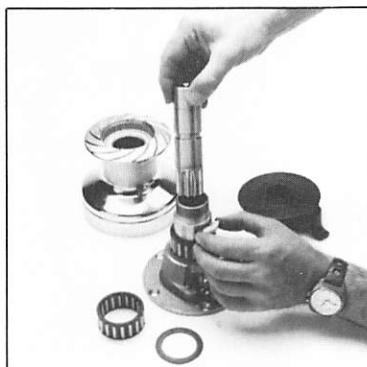

Remove centre spindle key and slide out spindle.

6

No. 16ST



Clean spindle, grease lightly and oil pawls.

7  
No. 30ST,  
34ST

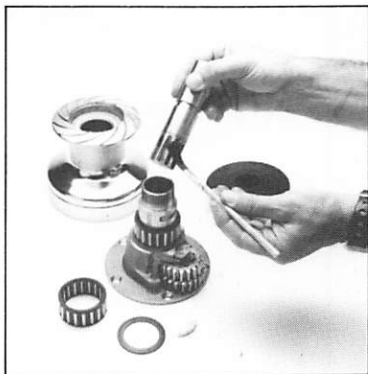

Clean and lightly grease spindle.

8  
No. 16ST

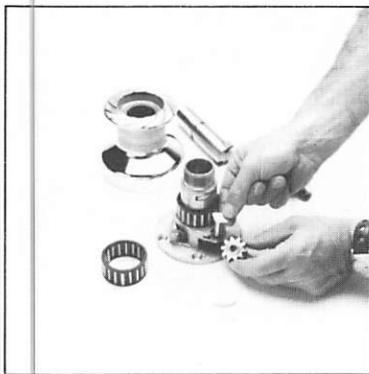

Remove gear, clean and lightly grease.

9  
No. 30ST,  
34ST



Remove pawl gears and clean. Lightly oil  
pawls and grease gears.

10

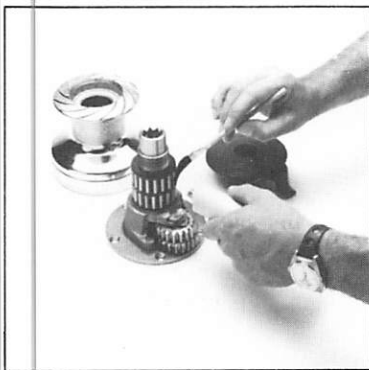

Reassemble spindle and gears. Lightly  
grease top cap thread, bearing and oil  
pawls in winch base.

Reassemble winch in reverse sequence to above. Check for correct operation.

# Wavegrip Self-Tailing 40ST, 42ST, 44ST, 48ST, 55ST, 65ST Operation and Adjustment

1. The rope must be placed in the jaws correctly. The turn leading from the drum must be passed across the stripper mechanism as shown and placed into the jaws.

2. The winch must be mounted so that the loose sheet falls correctly into a secure stowage position. The position of the stripper arm can be adjusted to give correct feed off of the sheet.

3. There must be a minimum of 3 turns of rope on the barrel.

4 The jaws are designed to accept a range of rope diameters. The winch should only be used with ropes of the sizes recommended.

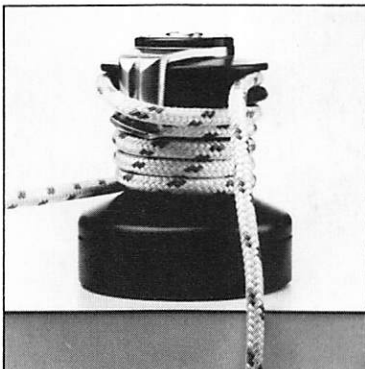

Range of Rope Diameters:

Cat. Nos.	Circumference (ins)	Diameter (mm)
40ST	1 - 1¼	8/14
42ST	1¼ - 2	10/16
44ST	1¼ - 2	10/16
48ST	1¼ - 2	10/16
55ST	1½ - 2¼	12/18
65ST	1¾ - 2½	14/20

1



To adjust remove the four socket head screws with a 1/16" A/F allen key. Lift off top plate.

2



Remove the two keys securing the stripper arm and lift off the stripper arm from its locating spline.

3



The stripper arm may now be rotated to the required position and relocated on the spline.

4



#### IMPORTANT

When refitting the stripper arm care must be taken to ensure it locates correctly against the stripper tongue which acts as a support.

# Wavegrip Self-Tailing 40ST, 42ST, 44ST, 48ST Servicing

1



Remove the 4  $\times \frac{1}{4}$ " UNC socket head screws and lift off top plate. Remove the two keys securing the stripper arm.

2



Lift off the stripper arm from its locating spline.

3



Lift off drum.

4



Clean centre stem, roller bearings, lower gears and drum bore with a non-fluffy cloth.

5



Remove centre spindle key and slide out spindle.

6



Clean spindle, grease lightly.

7

Nos. 40ST,  
42ST.



Remove pawl gears and clean. Lightly oil  
pawls and grease gears.

8

Nos. 44ST,  
48ST.



Remove socket head screws from centre  
stem with a  $\frac{1}{16}$ " A/F allen key.

9

Nos. 44ST,  
48ST.



Remove top of centre stem complete with  
spindle.

10

Nos. 44ST,  
48ST.



Remove spindle, lightly oil pawls and  
grease gear.

11

Nos. 44ST,  
48ST.



Remove pawl gears and clean. Lightly oil  
pawls and grease gears.

12

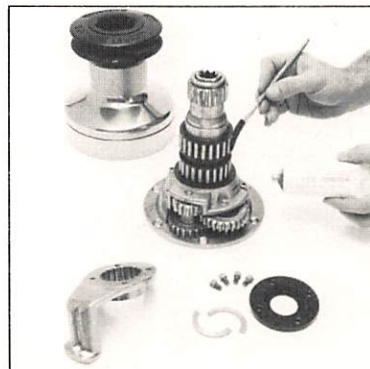

Reassemble, lightly grease roller  
bearings, output gear and gear teeth on  
winch drum.

Reassemble winch in reverse sequence to above. Check for correct position.



# Wavegrip Self-Tailing 55ST, 65ST Servicing

1



Remove the 4 x 1/4" UNC socket head screws and lift off top plate. Remove the two keys securing the stripper arm.

2

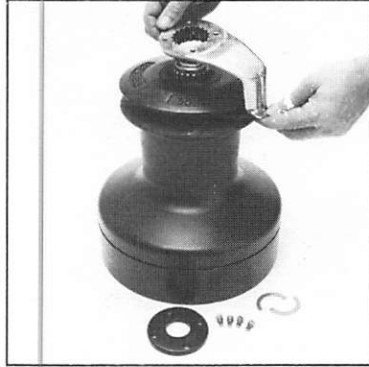

Lift off the stripper arm from its locating spline.

3



Lift off drum.

4



Clean centre stem, roller bearings, lower gears and drum bore with a non-fluffy cloth.

5



Lightly grease roller bearings, lower drum ring and gear teeth.

Reassemble winch in reverse sequence to above. Check for correct operation.

## Service Manual

A full Service Manual is available from your nearest Lewmar Service point. (Price £3.00/ \$6.00). Full servicing of any winch should not be undertaken without reference to this manual.

## Recommended Lubricants

**Grease:** Lewmar grease (7010) (Lubriplate Marine Lube 'A', etc)

**Oil:** Light machine oil (3 in 1 or equivalent)

## Tools Required

For routine servicing

Extra for full service (in conjunction with complete maintenance manual)

**Models 6, 7, 8, 10, 16, 24, 30, 42, 55, 65, 1H**  
Small screwdriver or knife blade  
Clean non-fluffy cloth  
Cleaning fluid  
Lubricants

**Models 6, 7, 8, 10, 16, 24, 30, 1H, 40, 42, 44, 48**  
Nil

**Models 16ST, 30ST, 34ST**  
plus soft mallet

**Models 55, 55ST**  
Screwdriver  
Hammer  
 $\frac{1}{16}$ " A/F allen key

**Models 40ST, 42ST, 44ST, 48ST, 55ST, 65ST**  
plus  $\frac{1}{16}$ " A/F allen key

**Models 65, 65ST**  
Hammer  
 $\frac{1}{16}$ " A/F allen key  
Medium screwdriver  
 $\frac{1}{2}$ " BSF spanner

**Models 44, 48, 44ST, 48ST**  
plus  $\frac{7}{32}$ " A/F allen key

## Winch Spares Kit

Lewmar provide a maintenance kit for each winch in their range. These kits contain parts which owners may damage or mislay. Each kit is complete and parts are not sold separately. Typical parts include  
Pawls, springs, circlips, washers, locking caps, etc.

### Spares Kits

Ref.

7001	Single speed winches except $\frac{5}{8}$ " socket No. 8's.
7002	Two speed and small self tailing winches up to and including 42ST except $\frac{5}{8}$ " socket No. 16.
7003	Three speed push button winches.
7004	Self tailing winches 44ST and above.
7005	Halliard reel winches.
7006	Three speed Disc type winches.
7007	Sprung loaded 34ST plus $\frac{5}{8}$ " socket Nos. 8 and 16 winches.
7008	Various circlips (Owners are strongly recommended to carry spare circlips for all winches).
7009	Allen key set.
7010	Grease.

Don't forget to get your spares kit from your local dealer.

**Lewmar Marine Limited Head Office**  
Southmoor Lane, Havant, Hampshire PO9 1JJ, England  
tel: Havant (0705) 471841 tlx: 86342 LEWMAR G

**Lewmar Marin AB**  
Box 60, Kirunaplan 5, 16211 Vallingby, Sweden  
tel: (08) 87 93 50 tlx: 11310 EXOTIC S

**Lewmar Sud Europe S.A.R.L.**  
156 Boulevard Emile Delmas  
17000 La Rochelle, France  
tel: (46) 34 27 67  
tlx: 792202 YACHTEQ F

**Lewmar Marine Inc. (East Coast)**  
Box 390  
125 Wilbur Place, Bohemia  
Long Island, NY 11716, USA  
tel: (516) 567 7770  
twx: 5102282615 LEWMAR BOMA

**Lewmar Marine Inc. (West Coast)**  
4009 Segerstrom Avenue,  
Santa Ana, California 92704, USA  
tel: (714) 979 5413 tlx: 678436 UWP SNA

**Lewmar Marine Limited**  
136 Adelaide Street East,  
Toronto, Canada M5C 1L6  
tel: (416) 363 6151  
tlx: 24332 TOMTAYCO TOR

Distributed by: -

All rights reserved,  
Copyright Lewmar Marine Ltd. 1980  
Printed in England  
Produced by Owen Print Group  
Code No. LHT 2.

 **LEWMAR**