

**NOTE:**  
 SEE PAGE 60A FOR SPECIFIC-  
 SEACOCK / THRUHULL / DECK FITTING LOCATIONS  
 SEE PAGE 60B FOR SPECIFIC-  
 SEACOCK / THRUHULL / DECK FITTING ASSEMBLY  
 SEE PAGE 64D FOR SPECIFIC-  
 MACERATOR, SENDING UNIT WIRING LAYOUTS  
 SEE FOLLOWING PAGE FOR  
 PART #'S, PART SIZES, ETC.

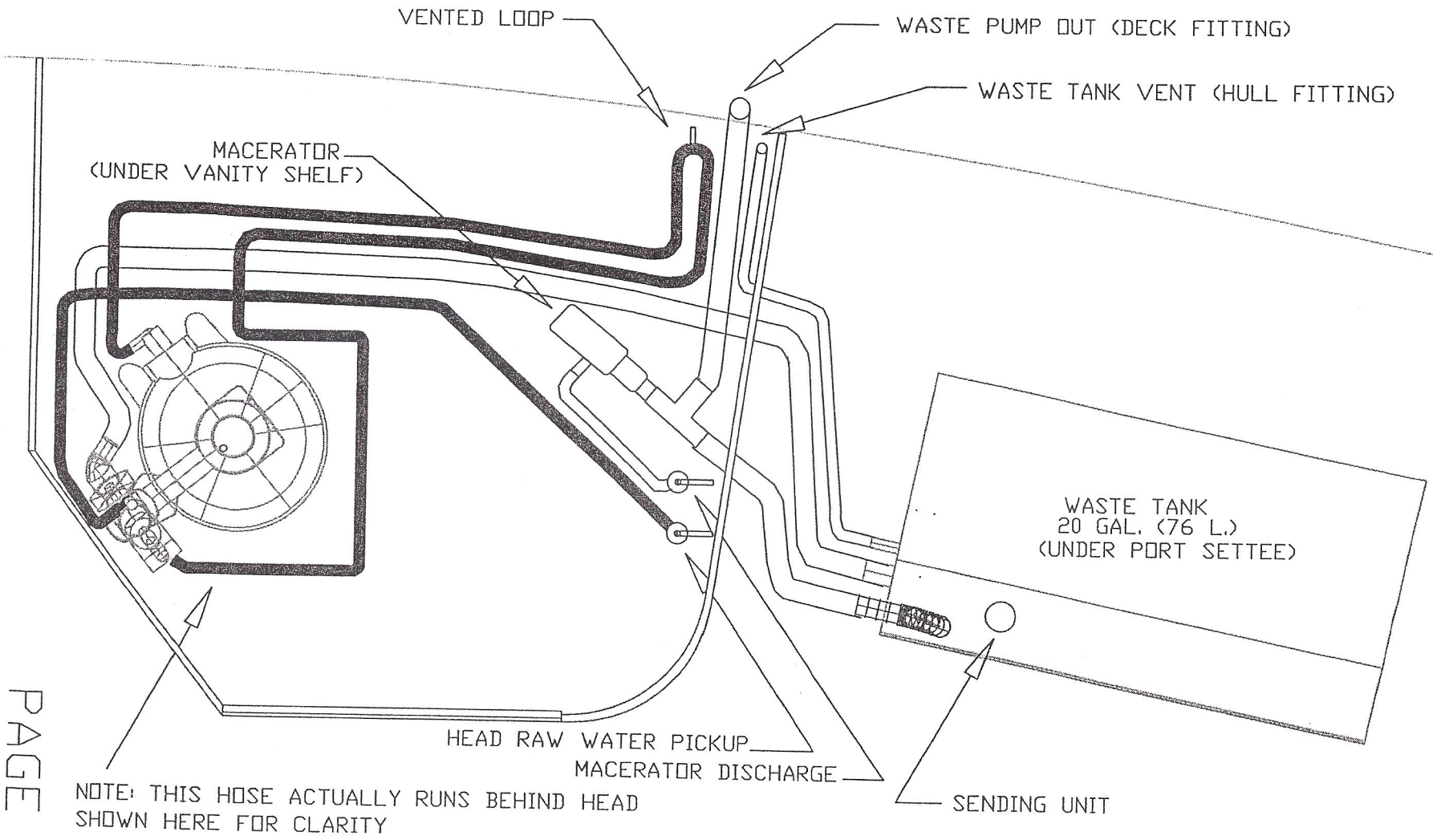

PAGE 58A

HEAD(S) & WASTE SYSTEM

**HUNTER**   
 H-310 WASTE SYSTEM  
 DRAWING # 3108058A

**HUNTER PART #'s**

WASTE (PUMP OUT) DECK FITTING.....PL1140  
 1" ( 25.4 MM ) BALL VALVE (DISCHARGE).....PL661A  
 1" ( 25.4 MM ) DISCHARGE THRU HULL FITTING.....PL0483  
 1" (25.4 MM ) WASTE (SEA) DISCHARGE HOSE.....PL1525  
 1-1/2" ( 38.1 MM ) DECK WASTE PUMPOUT HOSE.....PL1525

3/4" ( 19.1 MM ) BALL VALVE (INTAKE).....PL663A  
 3/4" ( 19.1 MM ) THRU HULL FITTING (INTAKE).....PL0482  
 3/4" ( 19.1 MM ) RAW WATER INTAKE HOSE.....PL1452

TANK VENT (HULL FITTING).....PL0520  
 3/4" ( 19.1 MM ) VENT HOSE.....PL1450

MACERATOR PUMP.....PL0328  
 VENTED LOOP.....PL0381

HOLDING TANK...SPECIFIC TO BOAT MODEL  
 HEAD...SPECIFIC TO BOAT MODEL  
 SEND UNIT...SPECIFIC TO BOAT MODEL

STANDARD WASTE SYSTEM LAYOUT (NON ELECTRIC HEAD MODELS)

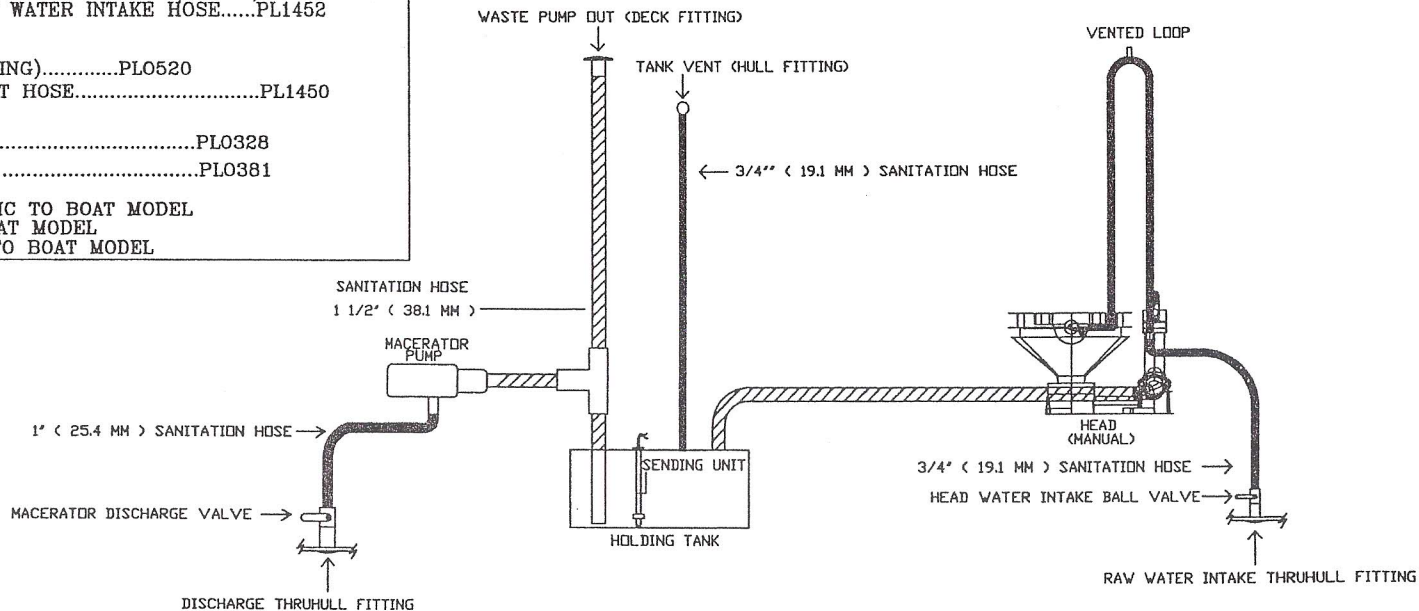

**NOTE:**

SEE PAGE 60A FOR SPECIFIC -  
 SEACOCK / THRUHULL / DECK FITTING LOCATIONS

SEE PAGE 60B FOR SPECIFIC -  
 SEACOCK / THRUHULL / DECK FITTING ASSEMBLY

SEE PAGE 64D FOR SPECIFIC -  
 SENDING UNITS / MACERATOR-  
 WIRING LAYOUTS

BILGE PUMP WIRING DETAIL

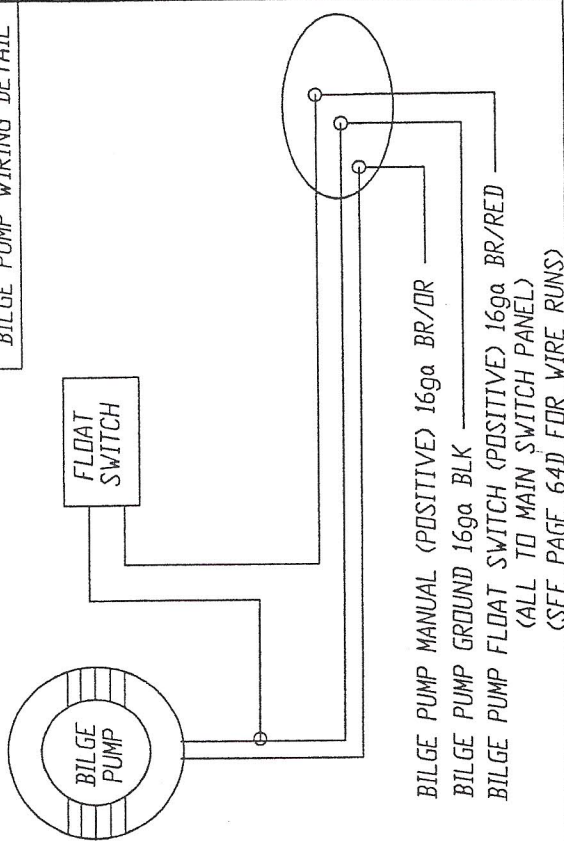

BILGE PUMP PLUMBING DETAIL

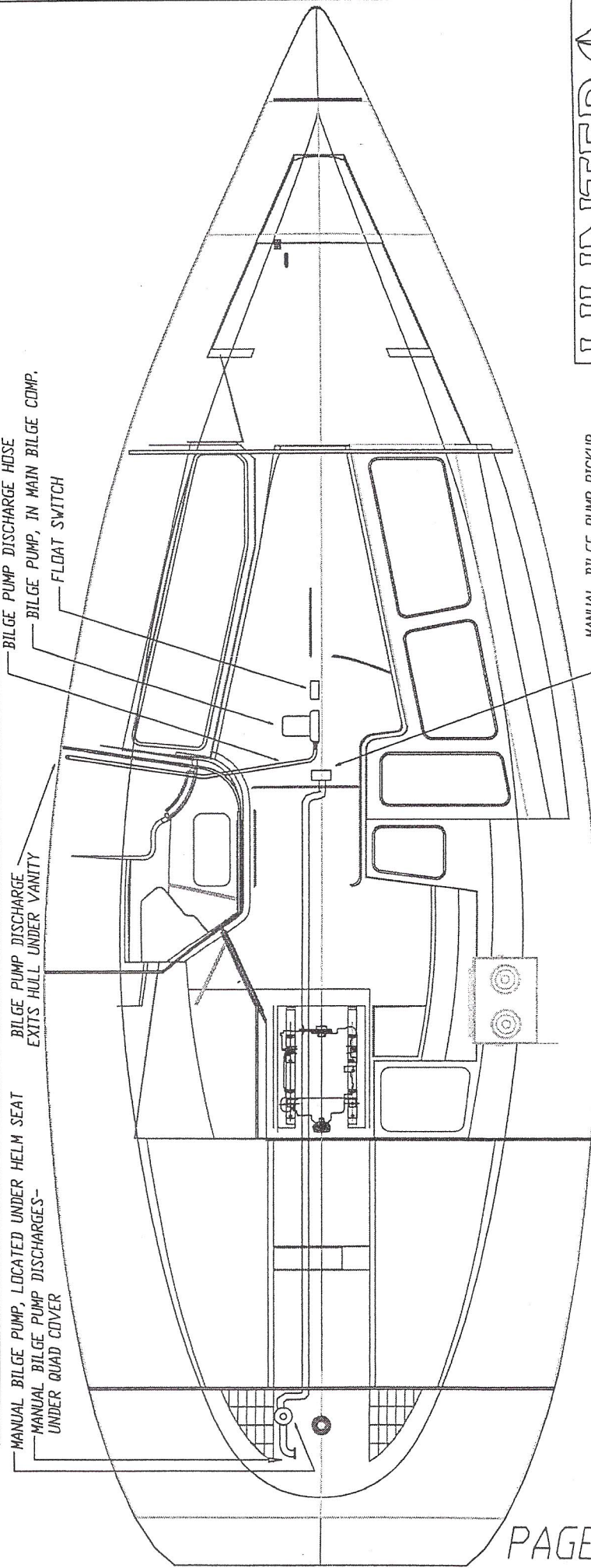
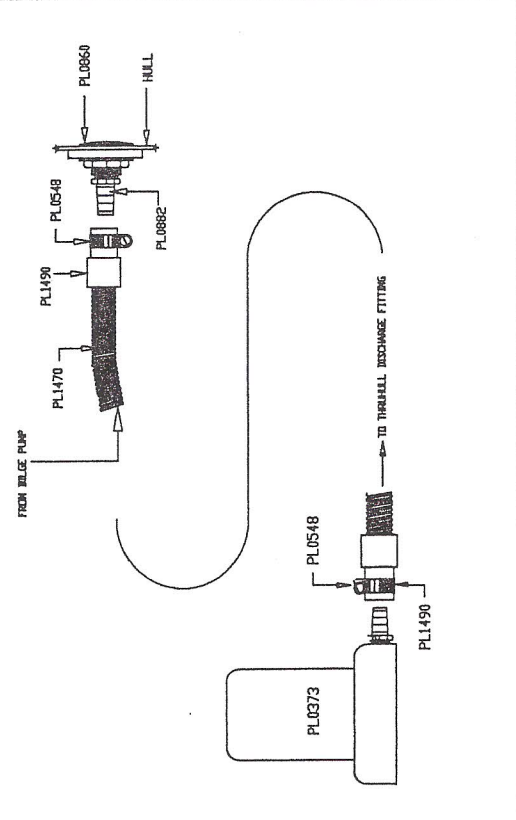

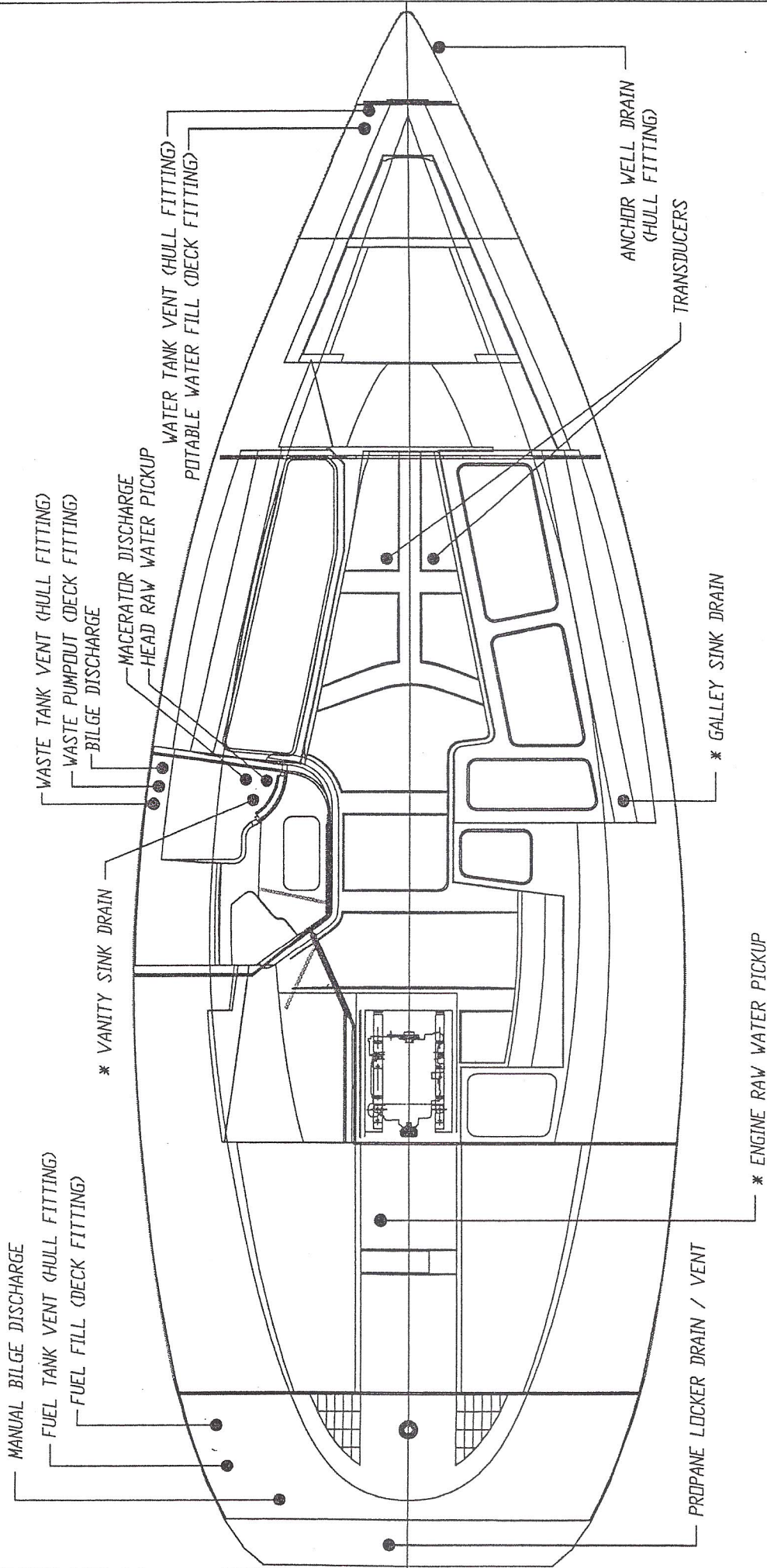

THRU HULL/DECK/SEACOCK LOCATIONS  
 ( \* = SEACOCKS )

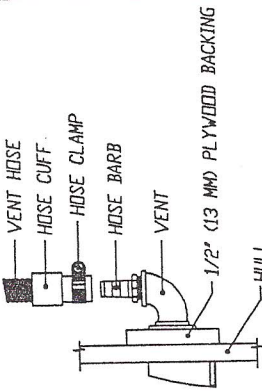
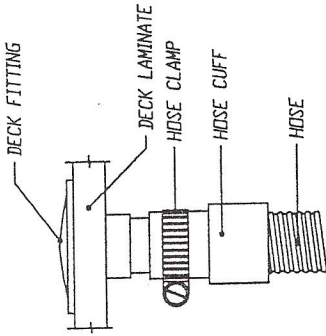
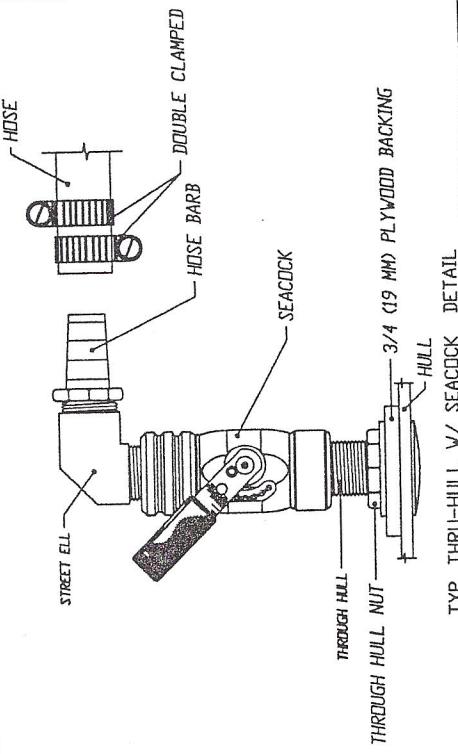
 <p>TYP. VENT DETAIL</p>	 <p>TYP. DECK PLATE DETAIL</p>	 <p>TYP. THRU-HULL V/ SEACOCK DETAIL</p>
<p>VENT HOSE SIZES AS FOLLOWS: H<sub>2</sub>O/WASTE/L.P. HOSE = 3/4" ( 19.1 MM ) FUEL HOSE = 5/8" ( 15.9 MM )</p>	<p>WATER TANK VENT...1/2" ( 12.7 MM ) WASTE TANK VENT...1/2" ( 12.7 MM ) DIESEL TANK VENT...1/2" ( 12.7 MM ) L.P. TANK VENT...1/2" ( 12.7 MM )</p>	<p>ENGINE WATER PICKUP MODELS 376 ON UP = 1" ( 25.4 MM ) MODELS 336 ON DOWN = 3/4" ( 19.1 MM )</p> <p>HEAD WATER PICKUP...3/4" ( 19.1 MM )</p> <p>GEN. WATER PICKUP (IF APPL.)...3/4" ( 19.1 MM )</p> <p>REF. WATER PICKUP (IF APPL.)...3/4" ( 19.1 MM )</p> <p>A. C. WATER PICKUP (IF APPL.)...3/4" ( 19.1 MM )</p> <p>SH. SUMP DIS. (IF APPL.)...3/4" ( 19.1 MM ) ALL MODELS EXCEPT P-42 P-42 = 1" ( 25.4 MM )</p>
<p>TYP. VENT SIZES</p>	<p>TYP. DECK PLATE SIZES (REFLECTS HOSE SIZE)</p>	<p>TYP. THRU-HULL/SEACOCK SIZES (REFLECTS HOSE SIZE)</p>

THRUHULL/DECK,SEACOCK,VENT, DETAILS

DESCRIPTION	HUNTER PART #
ENGINE FUEL FILTER	PLD430
GENER. FUEL FILTER (OPTION SOME MODELS)	PLD430
ENGINE FUEL FEED / RETURN HOSE 5/16" ( 7.9 MM )	PLI370
GENER. FUEL HOSE FEED / RETURN 1/4" ( 6.4 MM )	PLI415
DIESEL FILL FITTING	PLI126
TANK VENT FITTING	PLD520
DIESEL FILL HOSE 1 1/2" ( 38.1 MM )	PLI530
TANK VENT HOSE 3/4" ( 19.1 MM )	PLI450
TANK GAUGE	ELD1690B

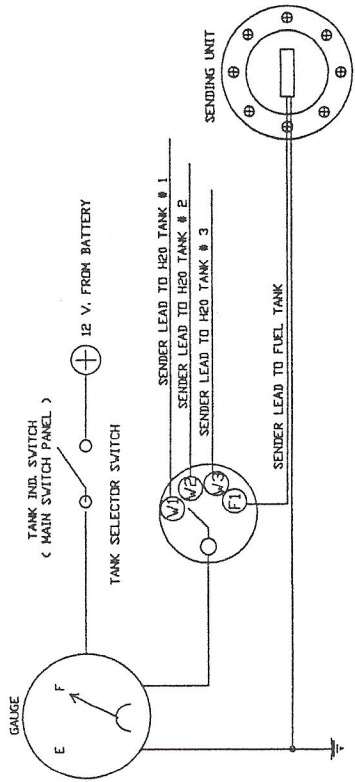

FUEL ( WATER TANK ) GAUGE WIRING DIAGRAM

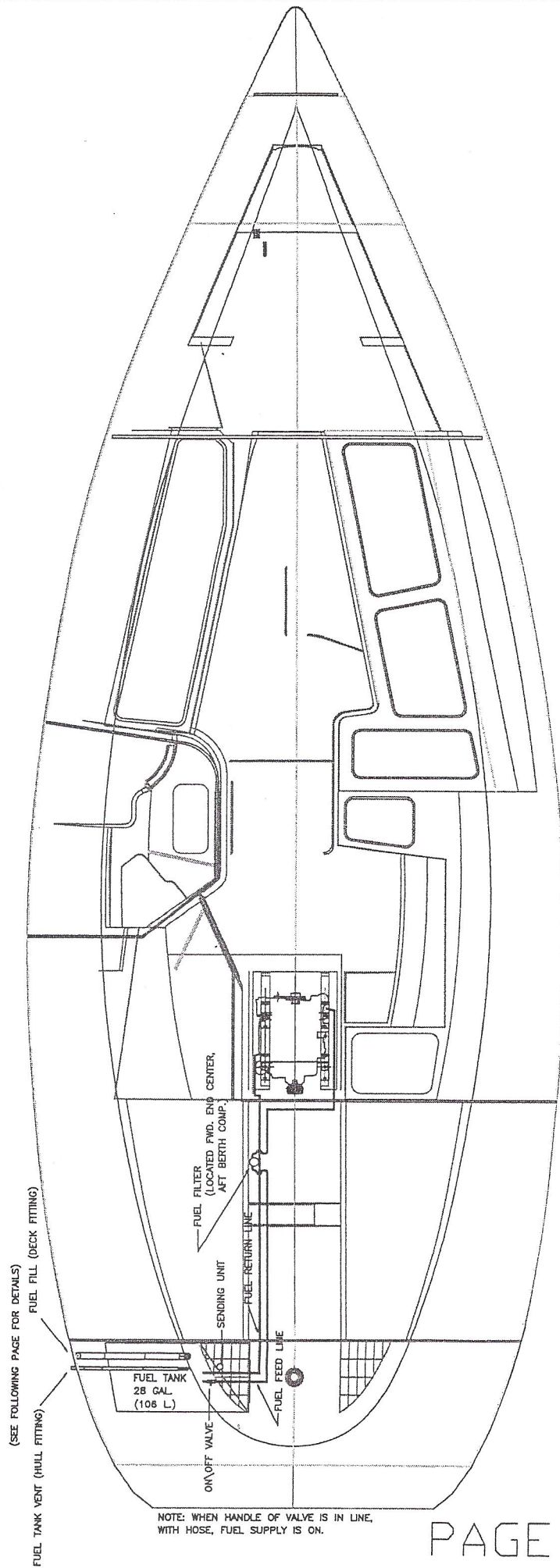

FUEL FILL (DECK FITTING)

FUEL TANK VENT (HULL FITTING)

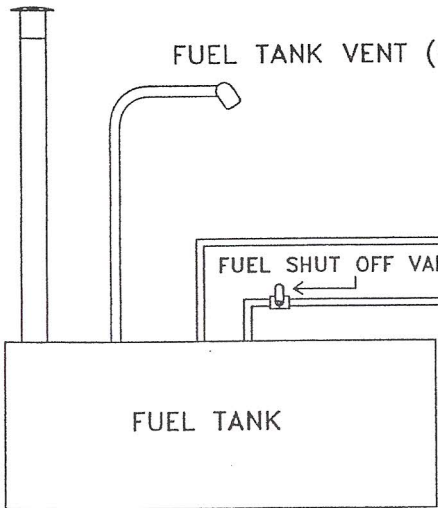

FUEL SHUT OFF VALVE

FUEL TANK

HUNTER PART #'s

FUEL FILL (DECK FITTING).....PL1126  
 1-1/2" FUEL FILL HOSE.....PL1530  
 1-1/2" HOSE CLAMP.....PL0550

FUEL TANK VENT (HULL FITTING).....PLO520  
 5/8" VENT HOSE.....PL1374  
 5/8"HOSE CLAMP.....PLO540

1/4" FUEL FEED & RETURN HOSE.....PL1415  
 1/4"HOSE CLAMP.....PL0536

FUEL SHUT OFF VALVE.....SUPP. BY TANK MANUF.  
 FUEL TANK.....SPECIFIC TO BOAT MODEL  
 ENGINE.....SPECIFIC TO BOAT MODEL

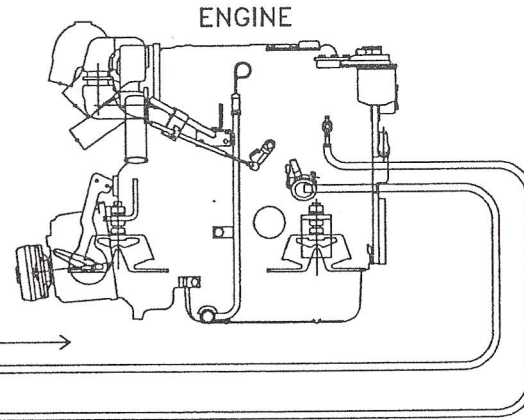

→ FUEL FEED LINE →

← FUEL RETURN LINE ←

NOTE: LOCATION OF FUEL FEED & RETURN LINES AT ENGINE VARY PER ENGINE MODEL

L.P.G. TANKS LOCATED  
PT. AFT SEAT COMP.

SEE FOLLOWING PAGE  
FOR MORE DETAILS.

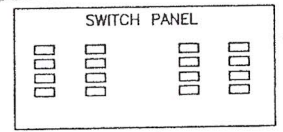

L.P.G. ON/OFF SWITCH

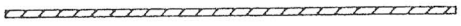
L.P.G. SUPPLY HOSE 

L.P.G. SOLENOID POWER LINE 

L.P.G. SYSTEM (310 MODEL)

**HUNTER** 

H-310 LPG SYSTEM  
DRAWING # 3108062A



NOTE: P-45 MODEL, TANKS ARE LOCATED IN PORT COCKPIT SEAT LOCKER

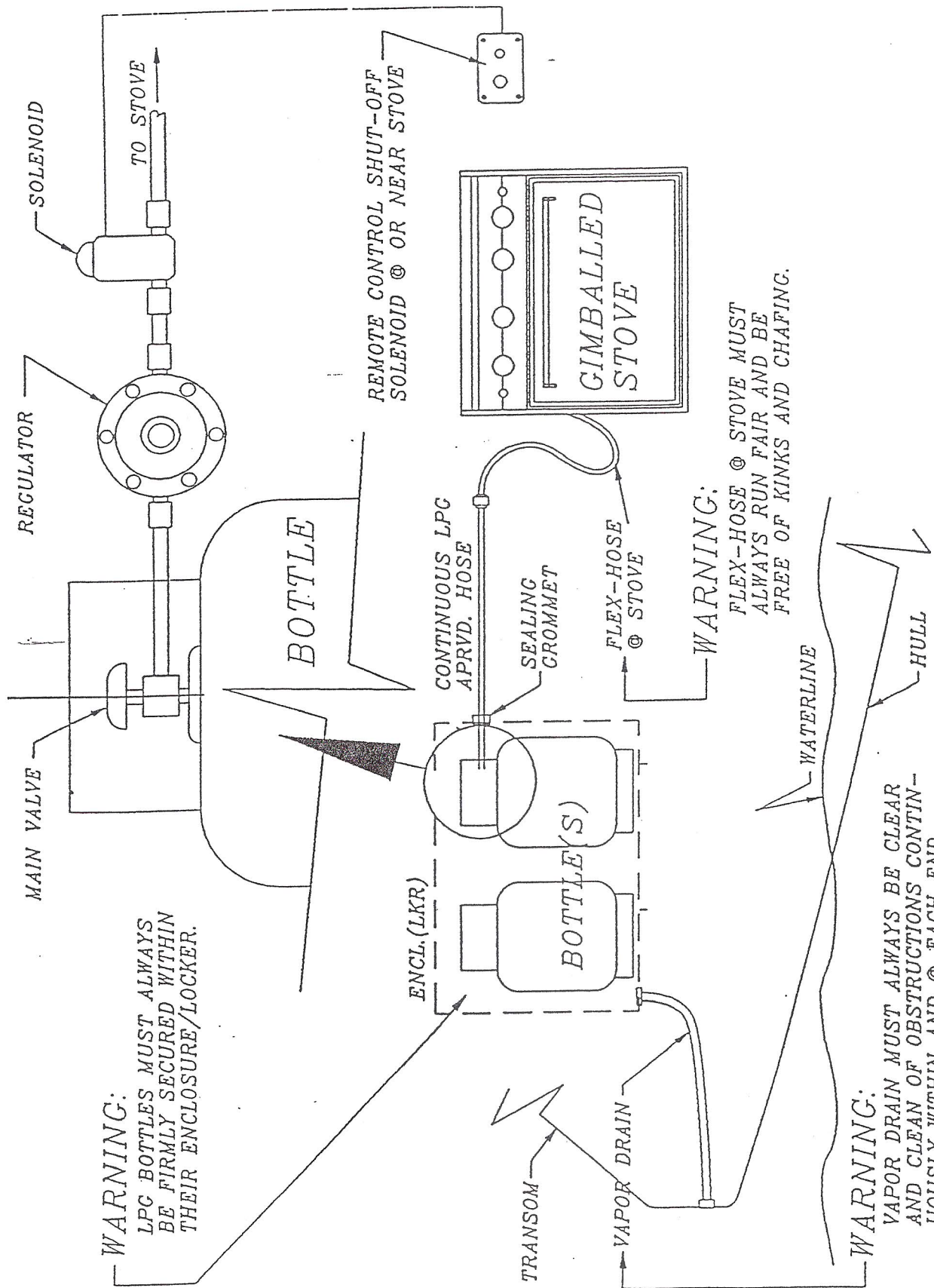

**WARNING:**

L.P.C. BOTTLES MUST ALWAYS BE FIRMLY SECURED WITHIN THEIR ENCLOSURE/LOCKER.

**WARNING:**

FLEX-HOSE @ STOVE MUST ALWAYS RUN FAIR AND BE FREE OF KINKS AND CHAFING.

**WARNING:**

VAPOR DRAIN MUST ALWAYS BE CLEAR AND CLEAN OF OBSTRUCTIONS CONTINUOUSLY WITHIN AND @ EACH END.

**HUNTER**

H-310 STD. LPG SYSTEM  
DRAWING # 3108062B

STD. L.P.G. SYSTEM LAYOUT

# H310 ELECTRICAL SYSTEMS

## H310 ELECTRICAL SYSTEM CONTENTS

PAGES 63A-10 THRU 63C-3 CONTAINS A.C. POWER SYSTEMS  
(110 V.A.C.) (220 V.A.C. ON OVERSEAS MODELS)

BASIC POWER SYSTEMS / MAIN DIST. PANEL DESCRIPTION .....	PAGES 63A-2 THRU 63A-6
SELECTOR SWITCH PANELS.....	PAGE 63A-7
POWER SYSTEMS TROUBLESHOOTING GUIDE .....	PAGES 63A-8 & 63A-9
<hr/>	
A.C. DISTRIBUTION PANEL SCHEMATIC: .....	PAGES 63A-10
A.C. POWER WIRING.....	PAGE 63A-11
OPTIONAL AIR CONDITIONING SYSTEM .....	PAGES 63B-1 & 63B-2
CHARGING SYSTEM.....	PAGES 63C-1 THRU 63C-3

### PAGES 64A-1 THRU 64G-3 CONTAINS D.C. POWER SYSTEMS (12 VOLT D.C.)

D.C. DISTRIBUTION. PANEL SCHEMATIC .....	PAGES 64A-1 & 64A-2
12 VOLT LIGHTING.....	PAGES 64B-1 & 64B-2
BILGE PUMP SCHEMATIC.....	PAGE 64C
INSTRUMENTS LAYOUT.....	PAGE 64D
V.H.F. RADIO LAYOUT.....	PAGE 64E
OPTIONAL REFRIGERATION .....	PAGE 64F1 THRU 64F-3
OPTIONAL WINDLASS SYSTEM.....	PAGE 64G-1 THRU 64G-3
WIRE CHASE LOCATIONS.....	PAGE 64H

### H310 POWER SYSTEMS OPERATION PROCEDURES

POWER SOURCE:	TO OPERATE:
(12V.) D.C. MAIN	<ol style="list-style-type: none"> <li>1. TURN BATTERY SWITCH (LOCATED INSIDE STBD. AFT COCKPIT LOCKER) TO THE #1, #2 OR "BOTH" POSITION.** (SEE BATTERY SEL. SW. NOTE BELOW)</li> <li>2. TURN ON "D.C. MAIN" BREAKER ON D.C. SIDE OF MAIN DISTRIBUTION PANEL. D.C. SIDE OF DISTRIBUTION PANEL SHOULD NOW BE OPERABLE. IF NO POWER: CHECK 50a. RESET ON BATTERY SWITCH PANEL AND/OR BATTERY CONNECTIONS.</li> </ol>
(110V.) A.C. MAIN (220V. A.C. ON SOME OVERSEAS MODELS)	<ol style="list-style-type: none"> <li>1. CONNECT SHORE POWER CABLE TO DOCKSIDE POWER SUPPLY AND SHORE POWER INLET ON STERN OF BOAT.</li> <li>2. TURN ON "A.C. MAIN" BREAKER ON A.C. SIDE OF MAIN DISTRIBUTION PANEL. A.C. SIDE OF DISTRIBUTION PANEL SHOULD NOW BE OPERABLE. IF NO POWER: CHECK BREAKER AT DOCKSIDE POWER SUPPLY BOX. CHECK A.C. BREAKER LOCATED ON PORT SIDE OF Q-BERTH HEADLINER.</li> </ol>

### H310 BATTERY CHARGING SYSTEM OPERATION PROCEDURES

CHARGE SOURCE:	TO OPERATE:
BATTERY CHARGER	<ol style="list-style-type: none"> <li>1. CONNECT SHORE POWER CABLE TO POWER A.C. SIDE OF MAIN DISTRIBUTION PANEL AND TURN ON THE "A.C. MAIN" BREAKER.</li> <li>2. TURN "BATTERY CHARGER" BREAKER (LOCATED ON "A" SIDE OF A.C. PANEL) TO THE "ON" POSITION NOTE: IT IS NOT NECESSARY TO TURN ON THE BATTERY SWITCH TO PROVIDE CHARGING POWER TO THE BATTERY/S.**</li> </ol>
ENGINE ALTERNATOR	<ol style="list-style-type: none"> <li>1. CHECK SEA STRAINER &amp; OPEN ENGINE RAW WATER SEACOCK. SEE PAGE 60 FOR LOCATION.</li> <li>2. TURN BATTERY SELECTOR SWITCH TO THE #1, POSITION.**</li> <li>3. START SHIP'S ENGINE (FOLLOW STARTING INSTRUCTIONS IN THE "ENGINE MANUAL")</li> </ol>
**BATTERY SEL. SWITCH	<p>NOTE: THE H310 IS CAPABLE OF HAVING TWO BATTERIES IF DESIRED (2ND BATT. NOT PROVIDED) SEE PAGE 63C-3 FOR BATTERY CONNECTION/CHARGER DETAILS. WHEN CONNECTED AS SHOWN, YOU NOW HAVE ISOLATION CAPABILITIES BY TURNING THE SEL. SW. TO THE #1 OR #2 POSITION, OR DRAW POWER FROM BOTH BATTERIES WHEN SWITCH IS IN THE "BOTH" POSITION.</p>

A.C. RESET BREAKER  
Q-BERTH HEADLINER, PORT SIDE

MAIN DIST.  
PANEL

BATTERY SWITCH  
(LOCATED INSIDE STBD. AFT COCKPIT LOCKER)

GROUND BUSS BAR  
(LOCATED BEHIND BATTERY SWITCH PANEL)

1. SHORE POWER INLET, SUPPLIES A.C. POWER FROM DOCKSIDE RECEPTACLE TO A.C. SIDE OF MAIN DISTRIBUTION PANEL  
2. BATTERY, SUPPLIES 12 V.D.C. POWER TO BOTH THE D.C. SIDE OF MAIN DISTRIBUTION PANEL & ENGINE STARTER

- ===== = 110 V.A.C. POWER LEADS (220 V. ON SOME OVERSEAS MODELS)
- =====:=====:=====: = 12 V.D.C. POWER LEADS
- > = POWER FLOW DIRECTION

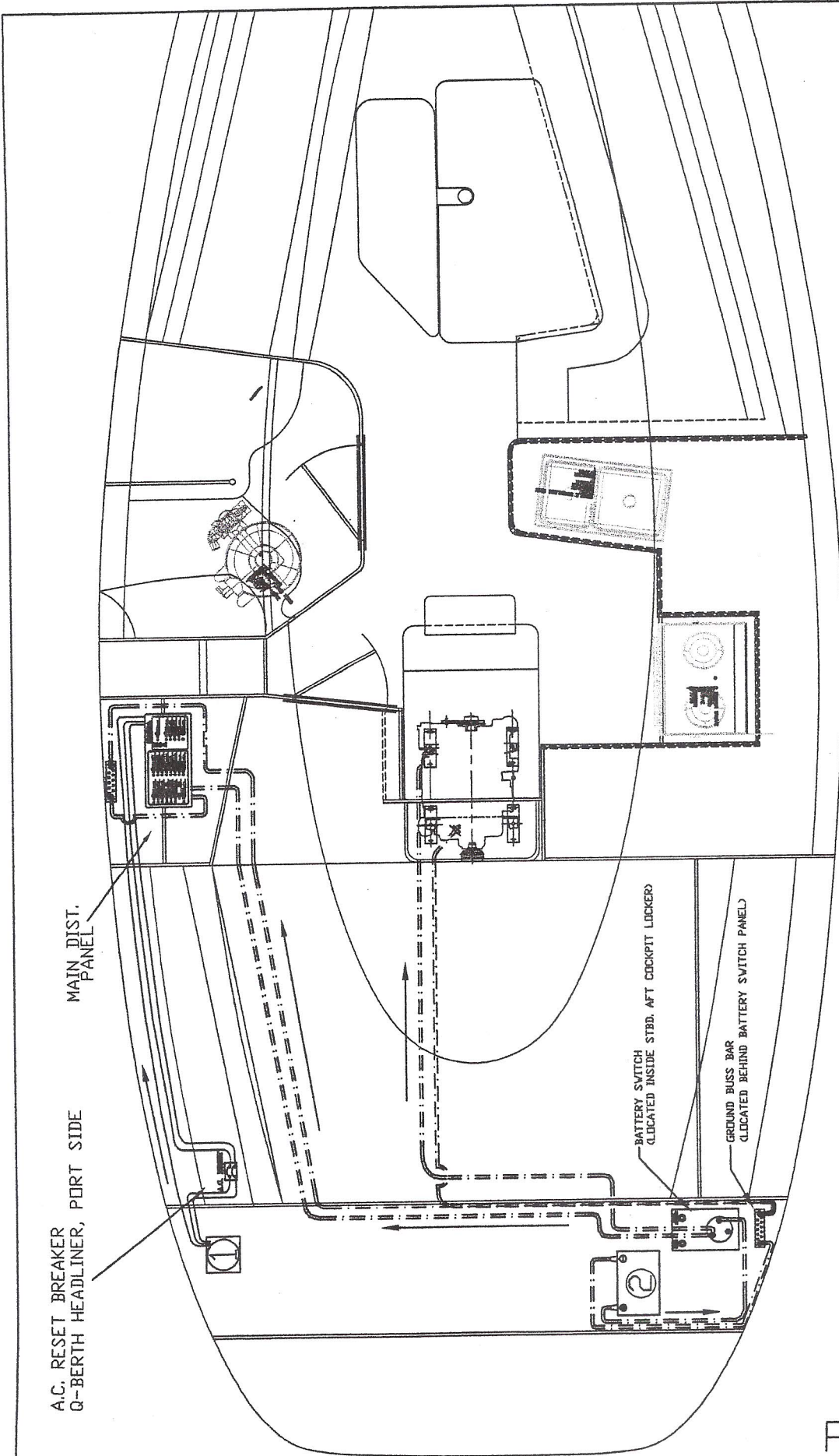

FIGURE TITLE: H310 BASIC POWER (SUPPLY) SYSTEM LAYOUT

FIGURE NO.	310B063A-3	REVISION NO.	NONE
DEPT.	ENGINEERING DEPT.	DATE	3/9/88

HUNTER

NOTE: THIS BREAKER MAY BE A 'FANS' BREAKER IF OPTIONAL AUTOPILOT WAS NOT CHOSEN. CAN BE USED FOR 'FANS' OR AS A 'SPARE' IF DESIRED, SINCE FANS ARE NOT PROVIDED.

# HUNTER

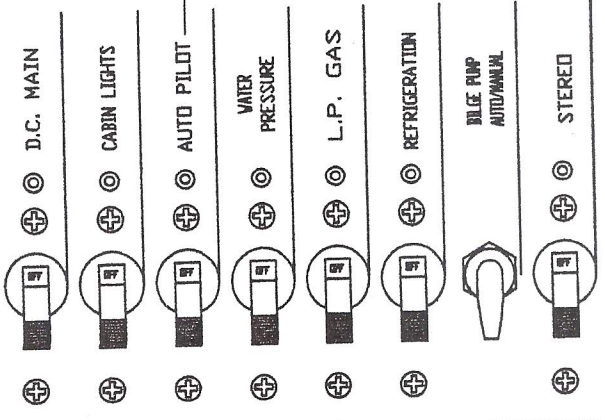
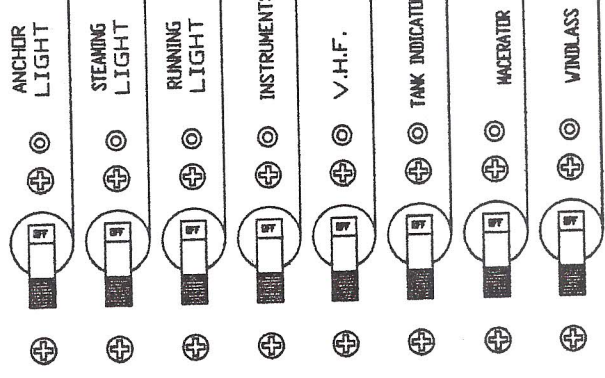
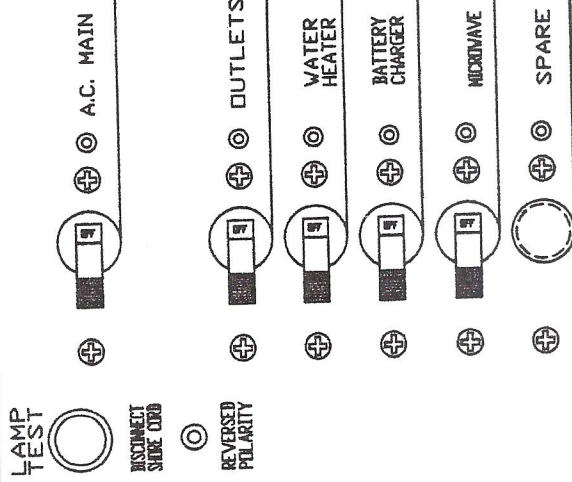

NOTE: THIS BREAKER MAY BE A 'SPARE' BREAKER IF OPTIONAL WINDLASS WAS NOT CHOSEN.

1. SHORE POWER TO A.C. SIDE OF PANEL
2. HOUSE BATTERY POWER TO D.C. SIDE OF PANEL

For General Information, Contact: HUNTER MARINE CORP., Box 10000, Seattle, WA 98108  
**HUNTER**

<b>H310 MAIN DISTRIBUTION PANEL</b>	
FORM NO. 3108083A-4	REVISION NO. NONE
ENGINEERING DEPT.	DATE 3/9/98

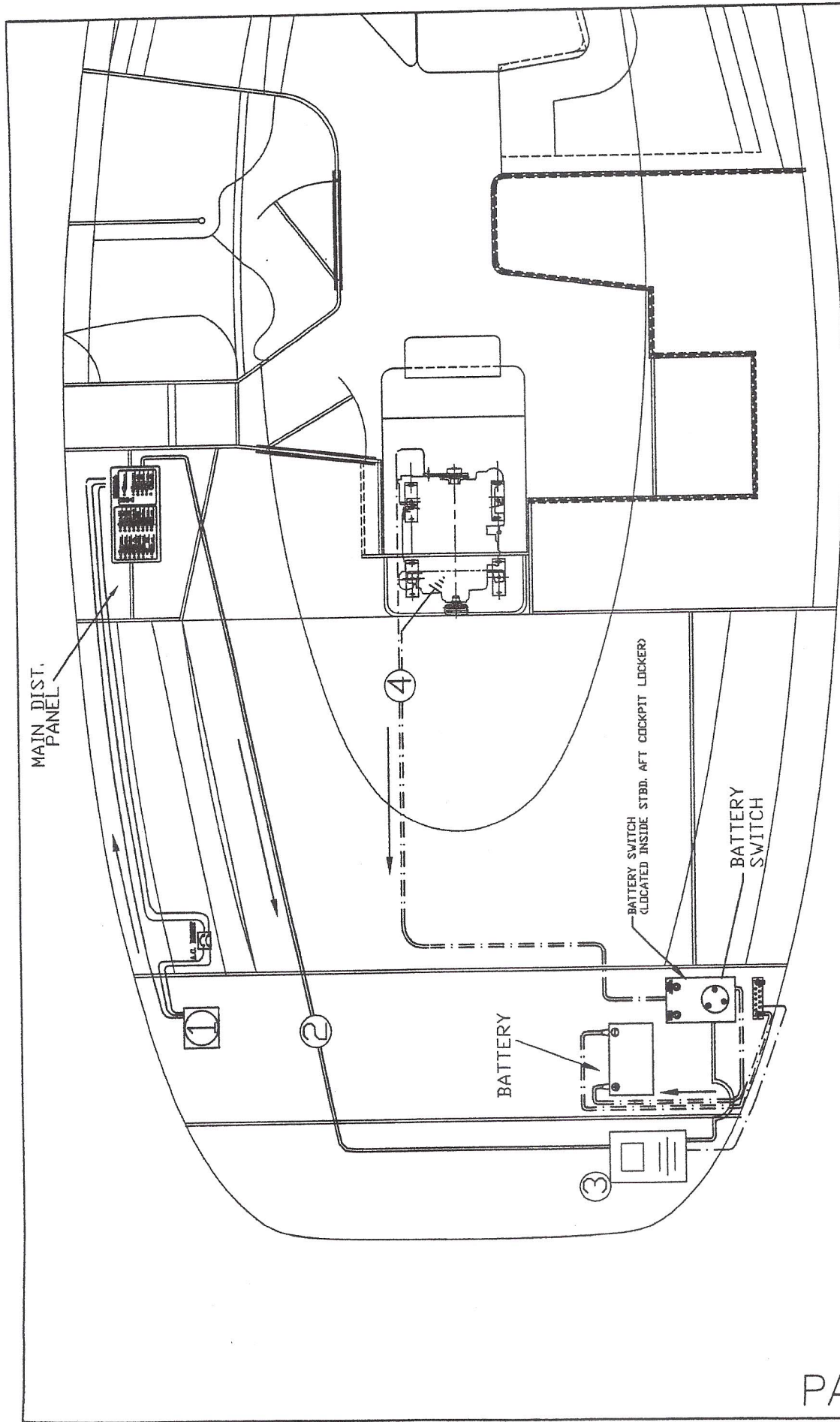

1. SHORE POWER INLET, SUPPLIES A.C. POWER FROM DOCKSIDE RECEPTACLE TO A.C. SIDE OF MAIN DISTRIBUTION PANEL
2. A.C. POWER FROM PANEL TO BATTERY CHARGER
3. BATTERY CHARGER
4. ENGINE ALTERNATOR CHARGE CIRCUIT
- = 110 V.A.C. POWER LEADS  
 (220 V. ON SOME OVERSEAS MODELS)  
 = CHARGING CIRCUIT  
 = POWER FLOW DIRECTION

HUNTER  
 H310 BASIC CHARGING SYSTEM LAYOUT  
 DRAWING NO. 310B063A-5  
 REVISION NO. NONE  
 DATE 3/10/98  
 ENGINEERING DEPT.

## H310 DISTRIBUTION PANEL

BREAKER	(D.C. SIDE OF PANEL)	DESCRIPTION
D.C. MAIN		SUPPLIES 12 V.D.C. POWER FROM BATTERY TO ALL BREAKERS ON D.C. SIDE OF PANEL.
CABIN LIGHTS		SUPPLIES POWER TO ALL THE INTERIOR LIGHTING AND COCKPIT LIGHT
AUTO PILOT (OPTIONAL)		SUPPLIES POWER TO THE OPTIONAL AUTOPILOT MOTOR/COMPONENTS. NOTE: THIS BREAKER MAY BE A "FANS" BREAKER IF OPTIONAL AUTOPILOT WASN'T CHOSEN. MAY BE USED FOR "FANS" OR AS A "SPARE" IF DESIRED, SINCE FANS ARE NOT PROVIDED.
WATER PRESSURE		SUPPLIES POWER TO FRESH WATER PUMP TO PRESSURIZE H2O SYSTEM.
L. P. GAS		SUPPLIES POWER TO L.P. GAS SWITCH AT GALLEY. SEE "SEAWARD MANUAL" FOR OPER. & SAFETY INST.
REFRIGERATION		SUPPLIES POWER TO THE OPTIONAL REFRIGERATION COMPRESSOR LOCATED IN THE STBD. MAIN BUNK COMP.
BILGE PUMP		TOGGLE SWITCH STAYS IN THE "AUTO" POSITION, THIS ALWAYS FEEDS POWER TO THE FLOAT SWITCH (AS LONG AS BATTERY IS CONNECTED AND HAS AMPLE CHARGE) FOR MANUAL USE, PUSH SWITCH TO "MANUAL" PRIOR TO LEAVING VESSEL, "MANUALLY" TEST PUMP AND CHECK FLUID LEVELS (IF APPLIES) IN BATTERIES.
STEREO		BREAKER PROVIDED, STEREO IS NOT
ANCHOR LIGHT		SUPPLIES POWER TO 360 DEGREE LIGHT AT TOP OF MAST, USE WHEN ANCHORED AT NIGHT.
STEAMING LIGHT		SUPPLIES POWER TO STEAMING LIGHT (LOCATED W/ANCHOR LIGHT) USE AT NIGHT WHEN VESSEL UNDERWAY BY ENGINE POWER. (ALONG W/RUNNING LTS.)
RUNNING LIGHTS		SUPPLIES POWER TO THE BOW, STERN, & COMPASS LIGHT. USE AT NIGHT UNDER SAIL AND/OR ENGINE POWER.
INSTRUMENTS		SUPPLIES POWER TO KNOT & DEPTH, REPEATERS LOCATED ON SEAHOOD.
VHF		SUPPLIES POWER TO THE VHF RADIO LOCATED ON THE HELM CONSOLE. (ON SOME EXPORT MODELS THE V.H.F. RADIO IS LOCATED BY THE MAIN DISTRIBUTION PANEL)
TANK INDICATOR		SUPPLIES POWER TO TANK/S SENDING UNITS TO DISPLAY TANK LEVELS ON TANK GAUGES.
MACERATOR		SUPPLIES POWER TO MACERATOR (LOCATED IN PORT MAIN BUNK COMP.) NOTE: THIS DEVICE IS USED FOR DIRECT OVERBOARD DISCHARGE OF RAW SEWAGE, BE AWARE OF YOUR LOCAL BOATING REGULATIONS BEFORE USING.
WINDLASS (OPTIONAL)		SUPPLIES POWER TO UP/DOWN CONTROLS AT ANCHOR WELL. NOTE: IT IS GOOD PRACTICE TO START THE SHIPS ENGINE PRIOR TO OPERATING WINDLASS TO PREVENT BATTERY DRAIN. (IF NO POWER, CHECK RESET ON WINDLASS REMOTE PANEL)
YELLOW L.E.D.'S		LIGHT EMITTING DIODES ILLUMINATE WHEN 12 V.D.C. POWER PRESENT.
NOTE:		SEE PAGE 64A-1 FOR BREAKER AMPERAGES

BREAKERS	(A.C. SIDE OF PANEL)	DESCRIPTION
A.C. MAIN (SHORE POWER)		PROVIDES A.C. VOLTAGE TO MAIN DISTRIBUTION PANEL WHEN SHORE POWER CORD IS CONNECTED TO OUTLET AT DOCKING FACILITY.
OUTLETS		PROVIDES A.C. POWER TO THE OUTLETS IN THE Q-BERTH., GALLEY, HEAD, V-BERTH AND NAV. STATION NOTE: NO OUTLET PROVIDED IN HEAD ON SELECT 220 V. MODELS.
OUTLETS NOTE:		G.F.C.I. (GROUND FAULT CIRCUIT INTERRUPTER) OUTLETS ARE PROVIDED IN THE Q-BERTH & GALLEY. THE G.F.C.I. OUTLET IN THE Q-BERTH PROTECTS ALL THE OUTLETS ON THE PORT SIDE OF THE BOAT AND THE GALLEY G.F.C.I. OUTLET PROTECTS THE OUTLET ABOVE THE REFRIGERATOR. THE RED (RESET) BUTTON RESTORES POWER TO THE OUTLET/S IN THAT CIRCUIT. THE BLACK BUTTON (TEST) DISCONNECTS POWER TO THAT CIRCUIT.
WATER HEATER		SUPPLIES POWER TO WATER HEATER. <b>BE SURE TANK IS FULL AND SYSTEM IS FREE FROM AIR BEFORE APPLYING POWER TO HEATER TO PREVENT ELEMENT BURNOUT.</b>
BATTERY CHARGER		SUPPLIES POWER TO CHARGER FOR CHARGING BATTERY/S (IF 2ND BATT. DESIRED SEE PAGE 63C-3 FOR DETAILS)
MICROWAVE		SUPPLIES POWER TO OUTLET BEHIND MICRO. IN WHICH MICROWAVE IS PLUGGED INTO.
SPARE		THIS SPACE PROVIDED FOR AN ADDITIONAL BREAKER IF NEEDED
<b>MISC. INFO</b>		
RED L.E.D.'S		ILLUMINATE WHEN A.C. POWER PRESENT.
REV. POLARITY		IF REVERSED POLARITY L.E.D. ILLUMINATES AFTER CONNECTING SHORE POWER CORD, DISCONNECT CORD AND HAVE DOCKSIDE POWER CHECKED BY QUALIFIED PERSONELL.
NOTE:		SEE PAGE 63A-10 FOR BREAKER AMPERAGES

## H310 SWITCH PANELS

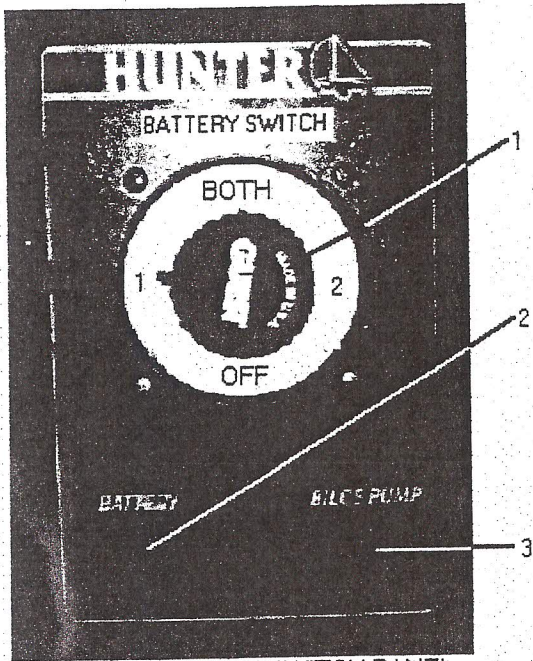

BATTERY ON/OFF SWITCH PANEL

1. BATTERY SWITCH
  2. BATTERY RESET
  3. BILGE PUMP RESET
- LOCATED IN STBD. AFT COCKPIT LOCKER.

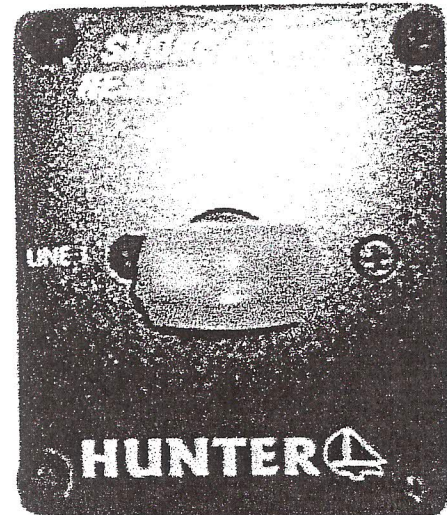

SHORE POWER RESET  
LOCATED IN Q-BERTH  
PORT AFT HEADLINER

**WINDLASS RESET PANEL**  
LOCATED IN STBD. AFT COCKPIT LOCKER.

1. TEST (ON/OFF) BUTTON, PUSH TO TRIP RESET
2. RESET, PUSH UP TO RESET

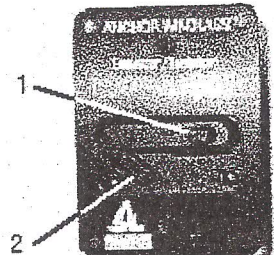

WINDLASS BREAKER

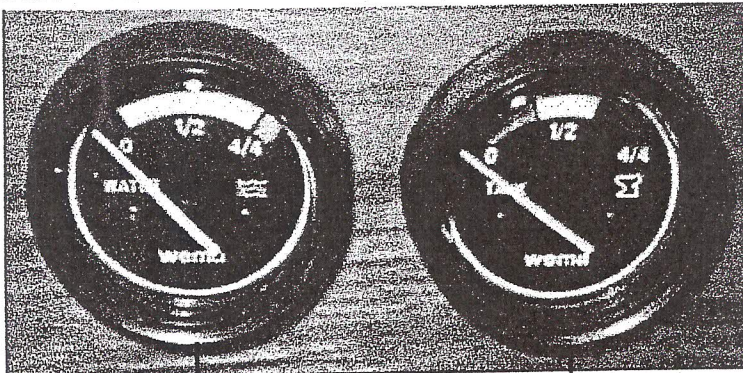

TANK GAUGES

WATER

WASTE

LOCATED NEXT TO DISTRIBUTION PANEL IN Q-BERTH



LP. GAS PANEL  
LOCATED AT GALLEY

1. L.P.G. ON/OFF SWITCH
2. SYSTEM "ON" L.E.D.
3. RESET BUTTON



## 12V.D.C. SYSTEM TROUBLESHOOTING GUIDE

TO POWER PANEL: 1. TURN BATTERY SWITCH TO THE #1 OR #2 OR "BOTH" POS. (LOCATED IN STBD. AFT COCKPIT LOCKER)  
 2. TURN ON "D.C. MAIN" BREAKER ON PANEL,  
**IF NO POWER TO PANEL, PUSH "RESET" ON BATTERY SWITCH PANEL**  
 AND/OR CHECK BATTERY CONNECTIONS.

COMPONENT	SYMPTOM	POSSIBLE SOLUTION/S
D.C. MAIN	NO POWER TO PANEL	SEE "TO POWER PANEL" ABOVE BATTERY/S CHARGED?
CABIN LIGHTS	WON'T ILLUMINATE	SEE "TO POWER PANEL" ABOVE BULB/S NEED REPLACING?
OPT. AUTO PILOT	WON'T OPERATE WON'T HOLD STEADY COURSE  CONSTANTLY ADJUSTING HELM	SEE "TO POWER PANEL" ABOVE IS THERE ANY METAL OBJECTS NEAR THE FLUX GATE COMPASS LOCATED BEHIND THE KICKBOARD BULKHEAD IN THE Q-BERTH ? SENSITIVITY SETTING SET TO HIGH, SEE "AUTO PILOT MANUAL" FOR SENS. ADJ.
WATER PUMP	NO POWER CYCLES ON/OFF EXCESSIVELY	SEE "TO POWER PANEL" ABOVE FAUCETS OFF? LEAK IN SYSTEM SEE PAGE 57A FOR CONNECTION LOC.
L.P. GAS	NO POWER TO SWITCH AT GALLEY SYSTEM TURNS ON, NO GAS PRESENT	SEE "TO POWER PANEL" PREV. PAGE IS TANK VALVE OPEN? IS TANK EMPTY? SEE "STOVE/OVEN" MANUAL
REFRIGERATION	WON'T GET COLD	SEE "TO POWER PANEL" ABOVE THERMOSTAT TURNED ON? SEE "REFRIGERATION" MANUAL SEEK QUALIFIED PERSONELL
BILGE PUMP	WON'T OPERATE AUTO OR MANUAL  PUMP MAKES NOISE, DOESN'T PUMP PUMP RUNS BUT DOESN'T DISCHARGE	BATTERY LEVEL O.K.? CHECK BILGE RESET ON BATT. SW. PANEL BATTERY CONNECTIONS GOOD? DEBRIS IN PUMP IMPELLER? DISCHARGE HOSE CLOGGED?
ANCHOR, STEAM., & RUNNING LIGHTS	WON'T ILLUMINATE	SEE "TO POWER PANEL" ABOVE CHECK CONNECTION/S @ TERMINAL STRIP ABOVE PANEL AT TOP OF COMPRESSION POST BULB/S NEED REPLACING?
INSTRUMENTS	REPEATERS DON'T OPERATE	SEE "TO POWER PANEL" ABOVE DO TRANSDUCERS NEED CLEANING? SEE "INSTRUMENTS" MANUAL
V.H.F. RADIO	WON'T OPERATE  TURNS ON WON'T TRANSMIT/RECEIVE	SEE "TO POWER PANEL" ABOVE RADIO TURNED ON? ANTENNA CONNECTED PROPERLY?
TANK INDICATOR	TANK LEVEL GAUGES DON'T ILLUMINATE TANK LEVEL DISPLAYED IS INCORRECT	SEE "TO POWER PANEL" ABOVE TANK SENDING UNIT NEEDS CLEANING
MACERATOR	WON'T TURN ON RUNS BUT DOESN'T DISCHARGE  PUMP MAKES NOISE, DOESN'T PUMP	SEE "TO POWER PANEL" IS DISCHARGE SEACOCK OPEN? IS WASTE DECK FITTING SECURE, IS IT PULLING AIR THRU? IF SO, TIGHTEN CAP OR REPLACE O- RING ON CAP. IS TANK VENT (HULL FITTING) CLOGGED? (SEE PAGE 60 FOR LOCATIONS) LODGED DEBRIS, TURN OFF POWER TO PUMP, INSERT SCREWDRIVER INTO PUMP ARMATURE AT END OF PUMP AND TURN TO DISLodge DEBRIS
WINDLASS (OPT.)	UP/DOWN CONTROLS DON'T OPERATE WINDLASS	SEE "TO POWER PANEL" ABOVE IS RESET "TRIPPED" ON WINDLASS RESET PANEL?
NOTE: COMPONENT/S FAILURE COULD ALSO BE THE RESULT OF A POOR "GROUND" CONNECTION. GROUND BUSS BARS ARE LOCATED IN THE STBD. AFT COCKPIT LOCKER, AND BEHIND THE MAIN DISTRIBUTION PANEL. DUE TO VIBRATION, WEATHER CONDITIONS, ETC. OCCASIONAL INSPECTION, CLEANING AND TIGHTENING OF THESE TERMINALS (BY QUALIFIED PERSONELL) MAY BE NECESSARY.		

# 110V.A.C. (220V. OVERSEAS MODELS) SYSTEM TROUBLESHOOTING GUIDE

- POWER PANEL:
1. CONNECT SHORE POWER CORD TO DOCKSIDE POWER SUPPLY AND SHORE POWER INLET ON STERN OF BOAT.
  2. TURN ON "A.C. MAIN" BREAKER ON MAIN DISTRIBUTION PANEL.  
IF NO POWER TO PANEL, CHECK DOCKSIDE BREAKER AND/OR A.C. RESET (BREAKER) ON Q-BERTH HEADLINER PORT SIDE.

COMPONENT	SYMPTOM	POSSIBLE SOLUTIONS
A.C. MAIN (SHORE POWER)	NO POWER TO PANEL	SEE TO POWER PANEL ABOVE
OUTLETS	NO POWER	SEE TO POWER PANEL ABOVE IS OUTLET BREAKER/S ON? CHECK RESET (RED BUTTON) ON G.F.C..I. OUTLETS AT GALLEY AND Q-BERTH
WATER HEATER	NO POWER  WON'T HEAT WATER  WATER TO COLD/HOT	SEE TO POWER PANEL ABOVE IS BREAKER ON? CHECK "RESET" ON HEATER SEE "WATER HEATER MANUAL" FOR LOCATION. SEE "WATER HEATER MANUAL" FOR THERMOSTAT ADJUSTMENT AND/OR ELEMENT REPLACEMENT, (SEEK QUALIFIED PERSONELL)
BATTERY CHARGER	NOT CHARGING BATTERY/S NOTE: 2ND BATTERY NOT PROVIDED AS STANDARD	SEE TO POWER PANEL ABOVE IS BATT. CHARGER BREAKER ON? ARE BATTERY CONNECTIONS GOOD? CHECK GROUND CONNECTIONS AT GROUND BUSS BAR SEE "CHARGER MANUAL"
GENERATOR	NOT CHARGING BATTERY/S	CHECK CONNECTIONS AND/OR SEE "ENGINE" MANUAL
MICROWAVE		SEE TO POWER PANEL ABOVE IS BREAKER ON? IS MICROWAVE ON? SEE "MICROWAVE MANUAL"

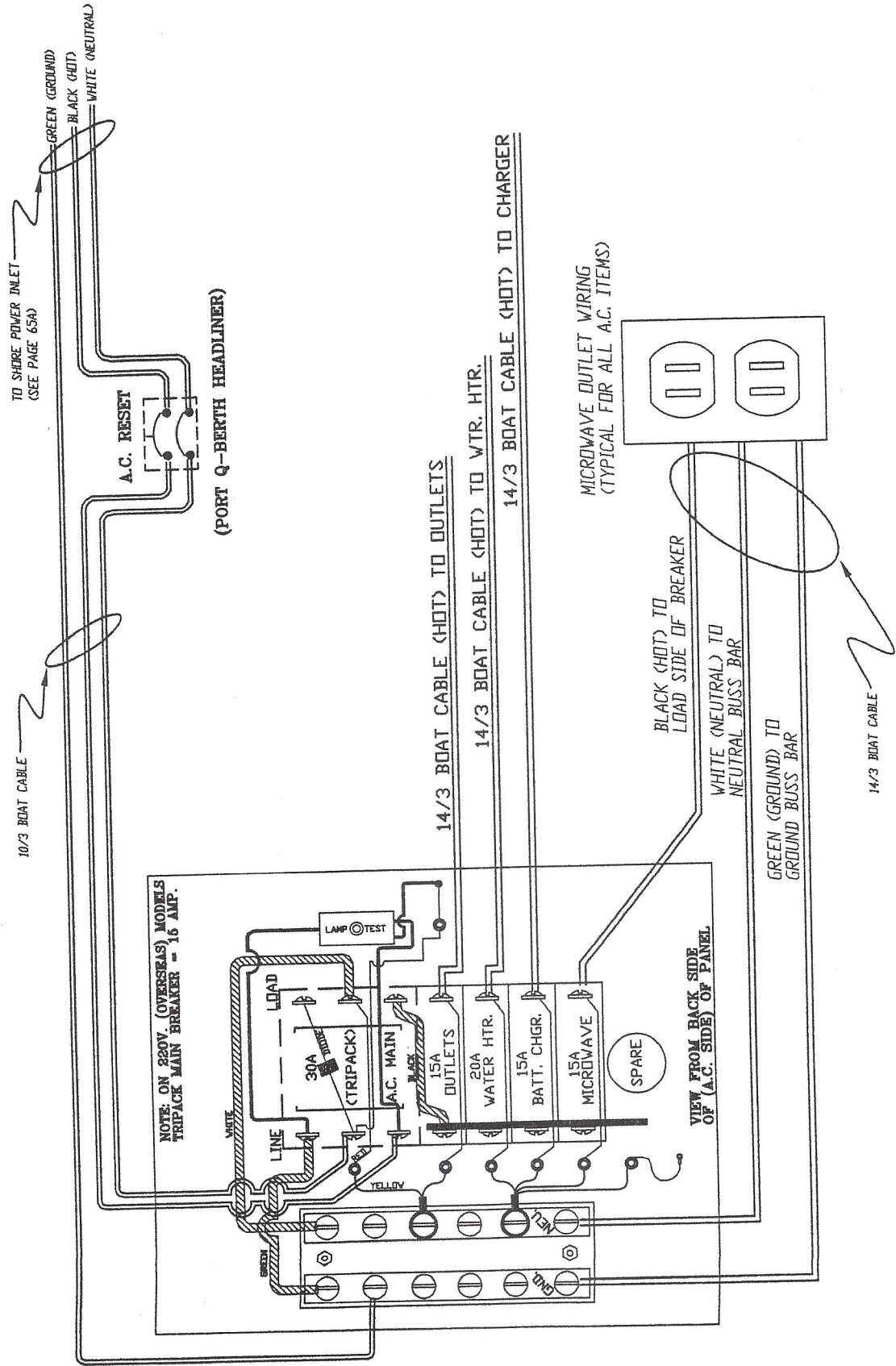

NOTE: ON 220V (OVERSEAS) MODELS TRIPACK MAIN BREAKER = 16 AMP.

VIEW FROM BACK SIDE OF (A.C. SIDE) OF PANEL

HUNTERA  
 H310 A.C. PANEL SCHEMATIC  
 DRAWING NO. 3108063A-10  
 REVISION NO. NONE  
 DATE 3/10/98  
 ENGINEERING DEPT.

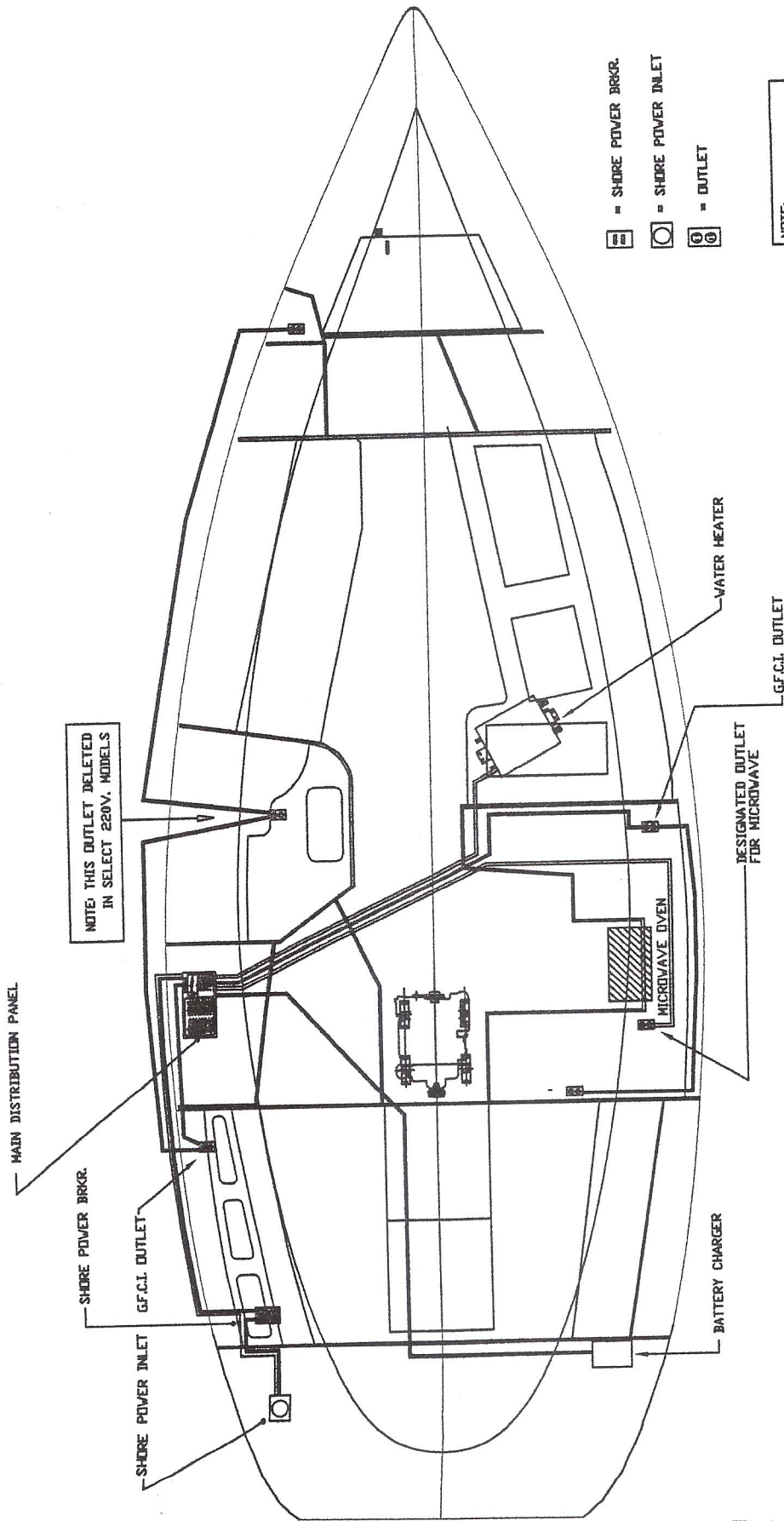

DRAWING TITLE: **H310 A.C. POWER PAN WIRING**  
 DRAWING NO: 5108063A-11  
 SCALE: NTS  
 DATE: 3/11/96  
 DRAWN BY: ENGINEERING DEPT.

HUNTER

SECTION 63C...BATTERY CHARGING SYSTEM

BASIC OPERATING INSTRUCTIONS:

- ① CONNECT SHORE POWER TO DOCKSIDE SUPPLY AND SHORE POWER INLET ON STERN OF BOAT
- ② TURN ON "A.C. MAIN" BREAKER
- ③ TURN ON "BATTERY CHARGER" BREAKER

NOTE:

CHECK FOR CORRECT FLUID LEVEL IN BATTERIES (IF APPLICABLE) PRIOR TO USING CHARGER.  
USE OF CHARGER (OR ENGINE ALT.) IS IMPORTANT WHEN USING 12V.D.C. SYSTEMS  
TO REDUCE BATTERY DRAIN.

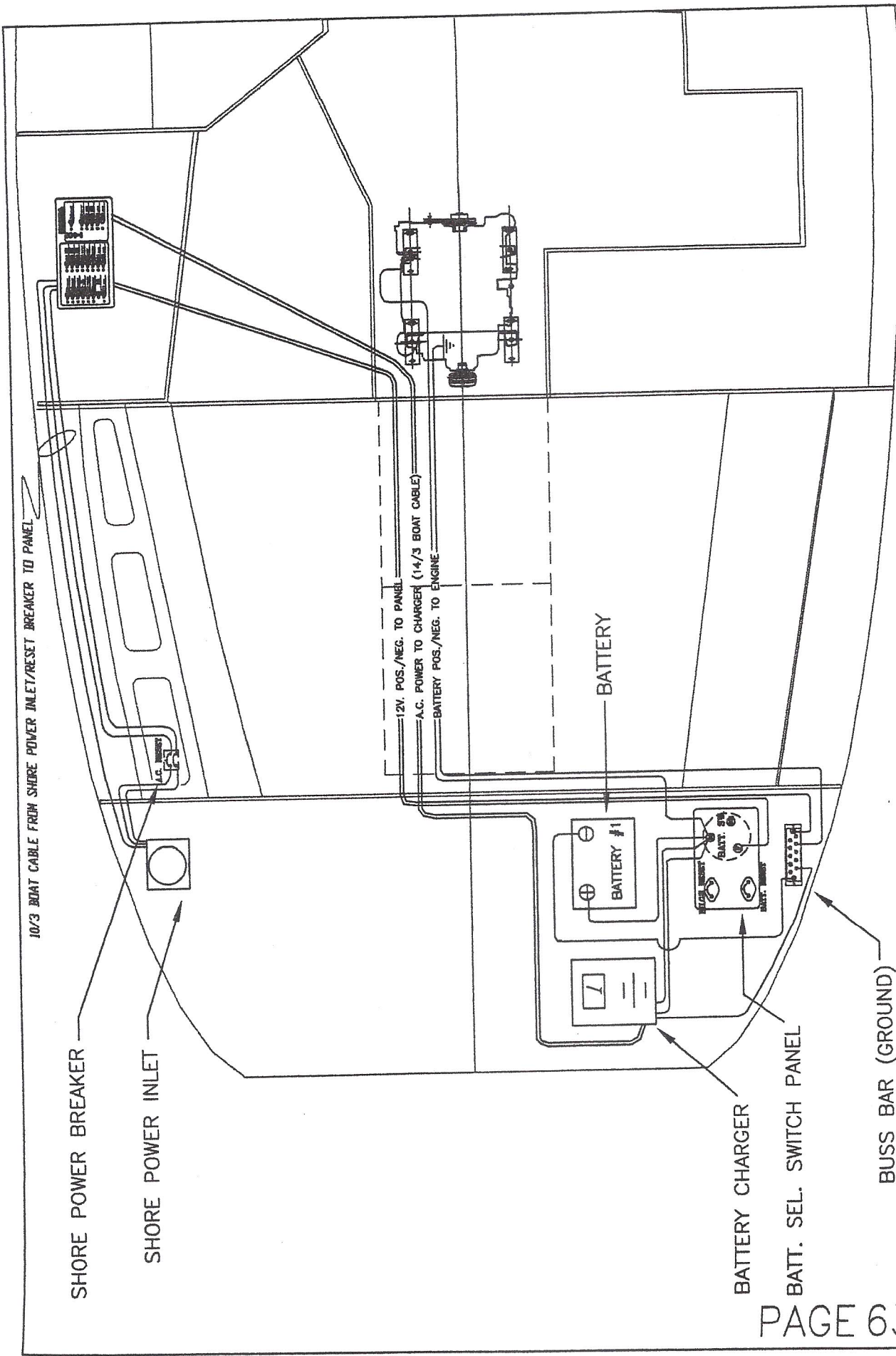

HUNTER  
 H370 CHARGING SYSTEM LAYOUT  
 PART NO. 108063C-2  
 REV. NTS  
 DATE 3/11/98  
 ENGINEERING DEPT.

NOTE: DIAGRAM REFLECTS SINGLE BATTERY (FACTORY WIRED) SYSTEM  
 CHARGER IS CAPABLE OF CHARGING 2 BATTERIES, SEE PAGE  
 63C-3 FOR 2ND BATTERY/CHARGER CONNECTION DETAILS.

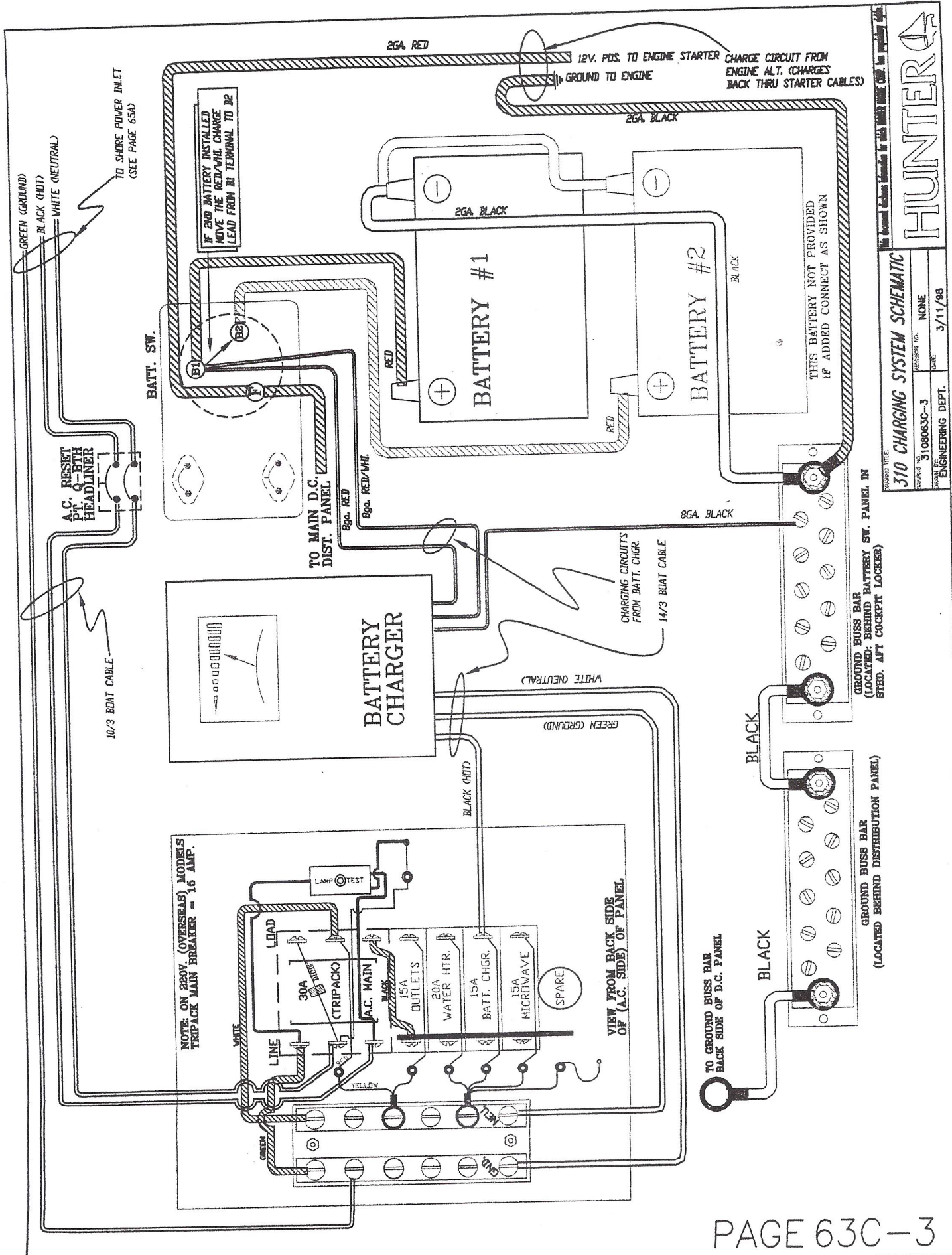

**HUNTER**

**310 CHARGING SYSTEM SCHEMATIC**

REVISION NO. 3108083C-3  
 DATE 3/11/88  
 DRAWN BY: NONE  
 CHECKED BY: ENGINEERING DEPT.

WINDLASS WIRING DETAIL

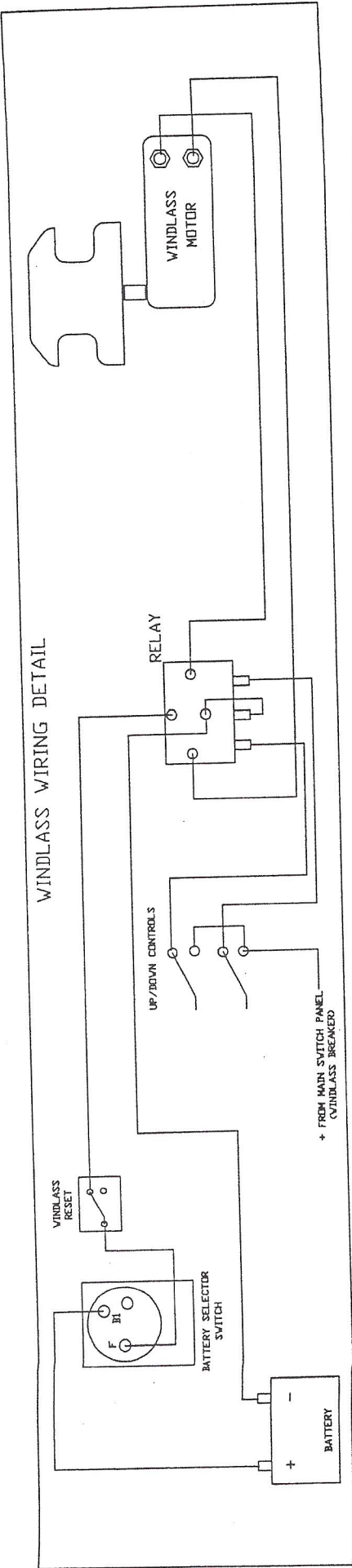

NOTE:  
SEE PAGE 65B FOR WIRE  
SIZE & COLOR CODES

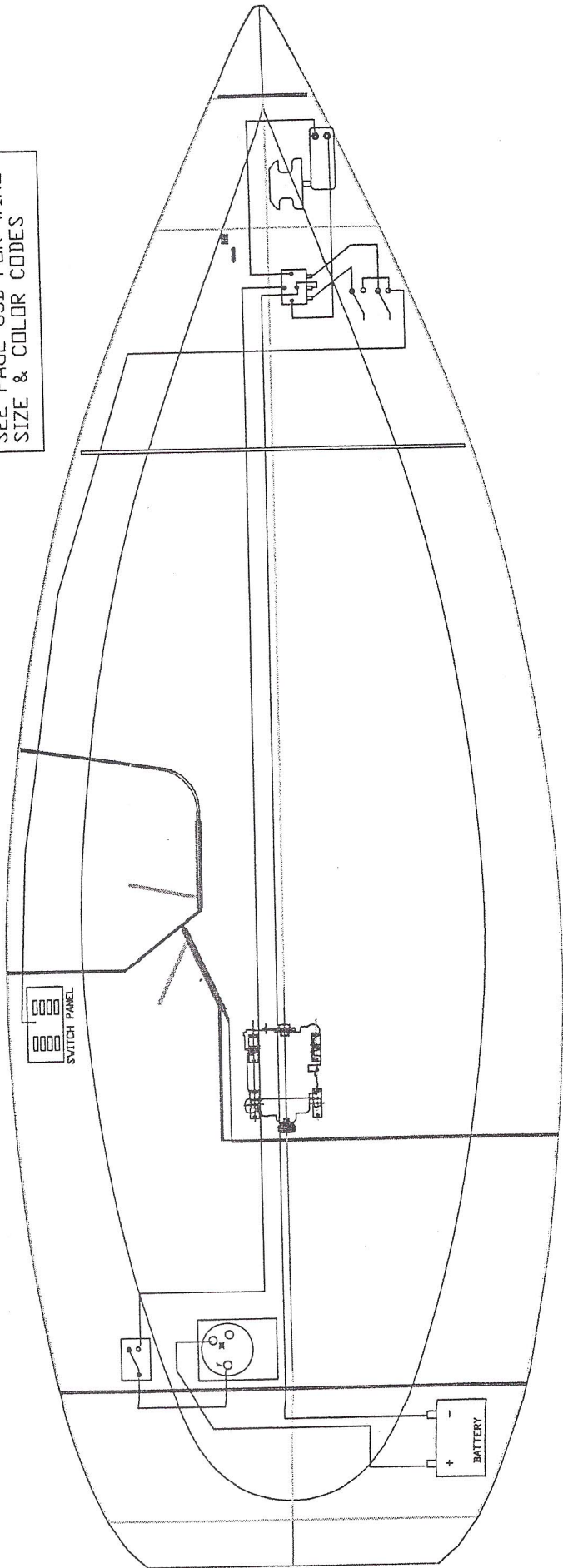



① AIR COND. COMPRESSOR  
(INSIDE GALLEY)

② 5" (127.0mm) AC DUCT

③ 3" (76.2mm) AC DUCT

④ VENTS

⑤ 3/4" (19.1mm) RAW WATER  
DISCHARGE

⑥ MAIN DISTRIBUTION PANEL

⑦ SEA STRAINER

⑧ RAW WATER INTAKE (SEACOCK) 3/4" (19.1mm)

⑨ CIRCULATION PUMP

⑩ ENVIRONMENT CONTROL UNIT (ECU)

⑪ CONTROL BOX

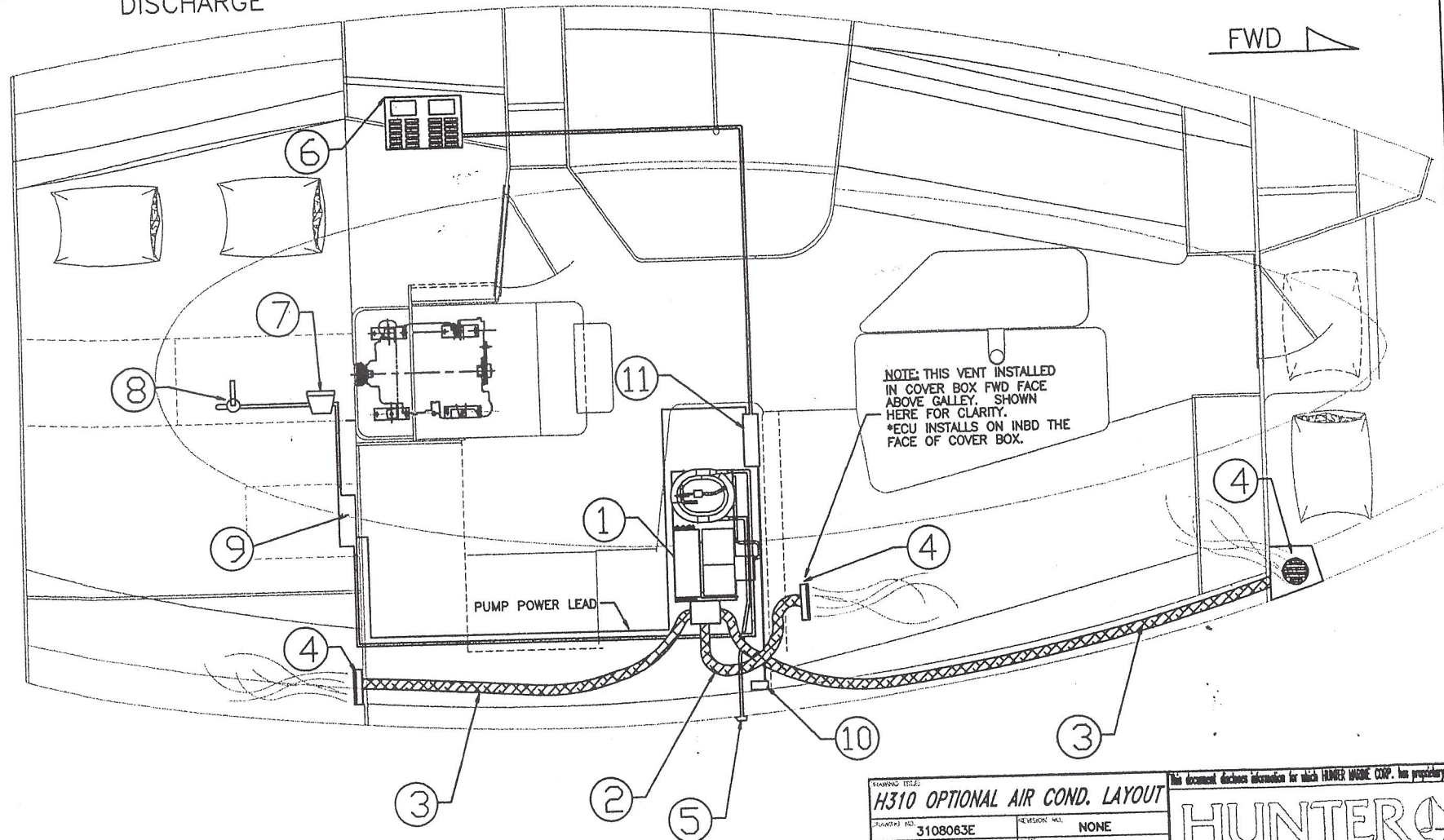

DRAWING TITLE: H310 OPTIONAL AIR COND. LAYOUT  
DRAWING NO.: 3108063E  
ENGINEERING DEPT.

REVISION NO.: NONE  
DATE: 2/13/98

This document discloses information for which HUNTER MARINE CORP. has proprietary rights.

HUNTER

NOTE:  
 SEE PAGE 65A FOR SPECIFIC  
 CHGR./BATT. SEL. WIRING LAYOUT  
 SEE PAGE 65B FOR SPECIFIC  
 WIRE SIZE & COLOR

SWITCH PANEL  
 □□□□  
 □□□□  
 □□□□  
 □□□□

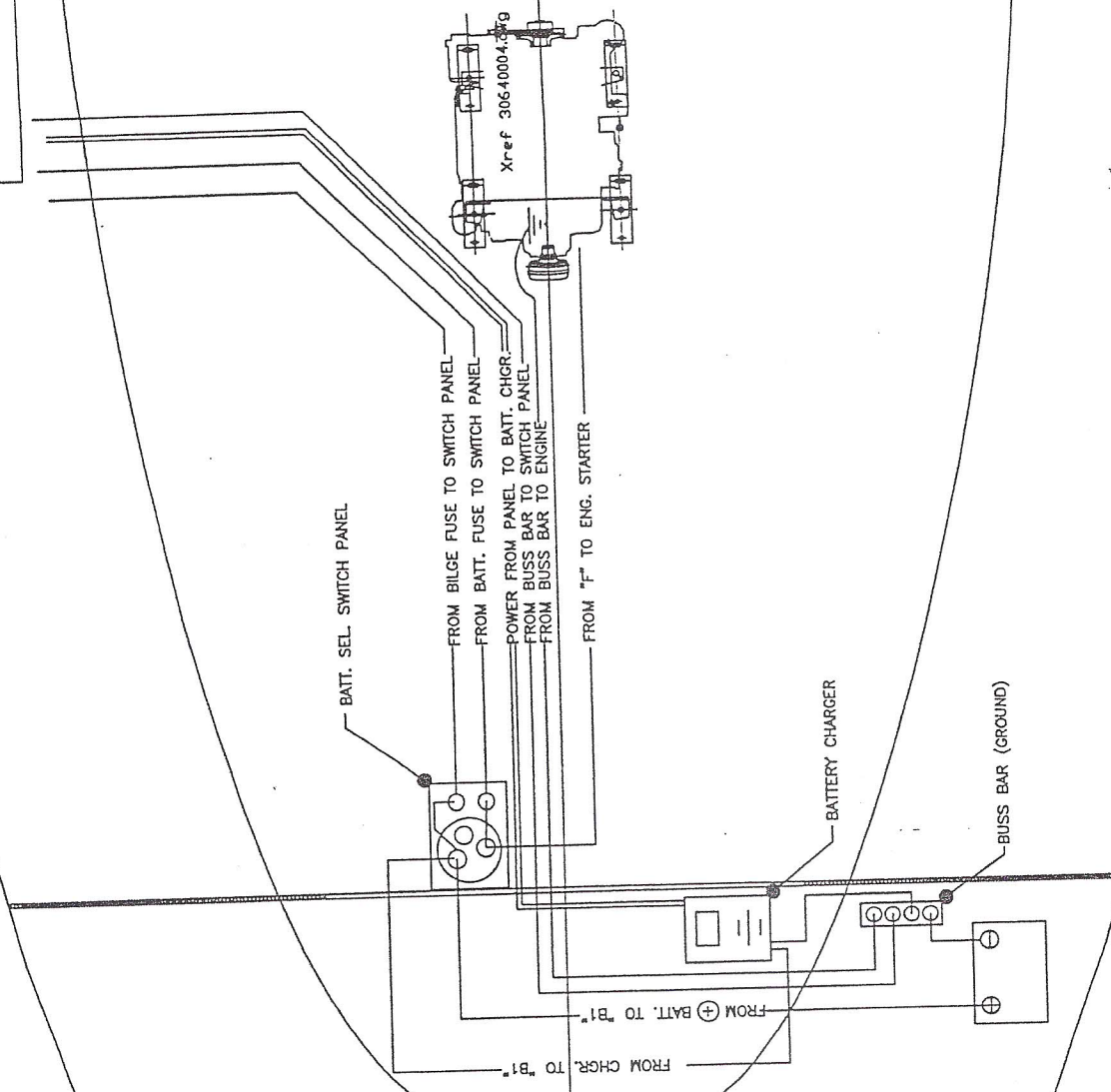

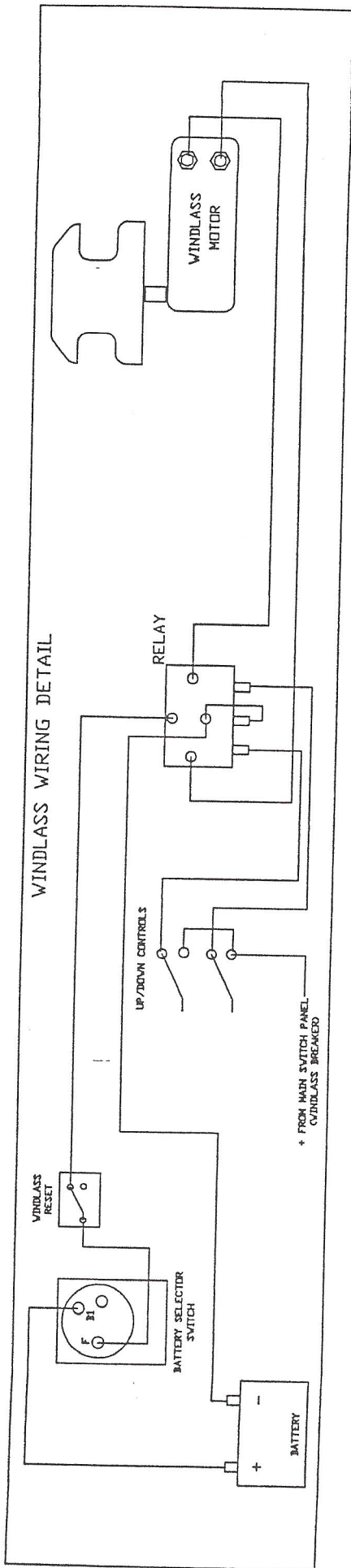

NOTE:  
SEE PAGE 65B FOR WIRE  
SIZE & COLOR CODES

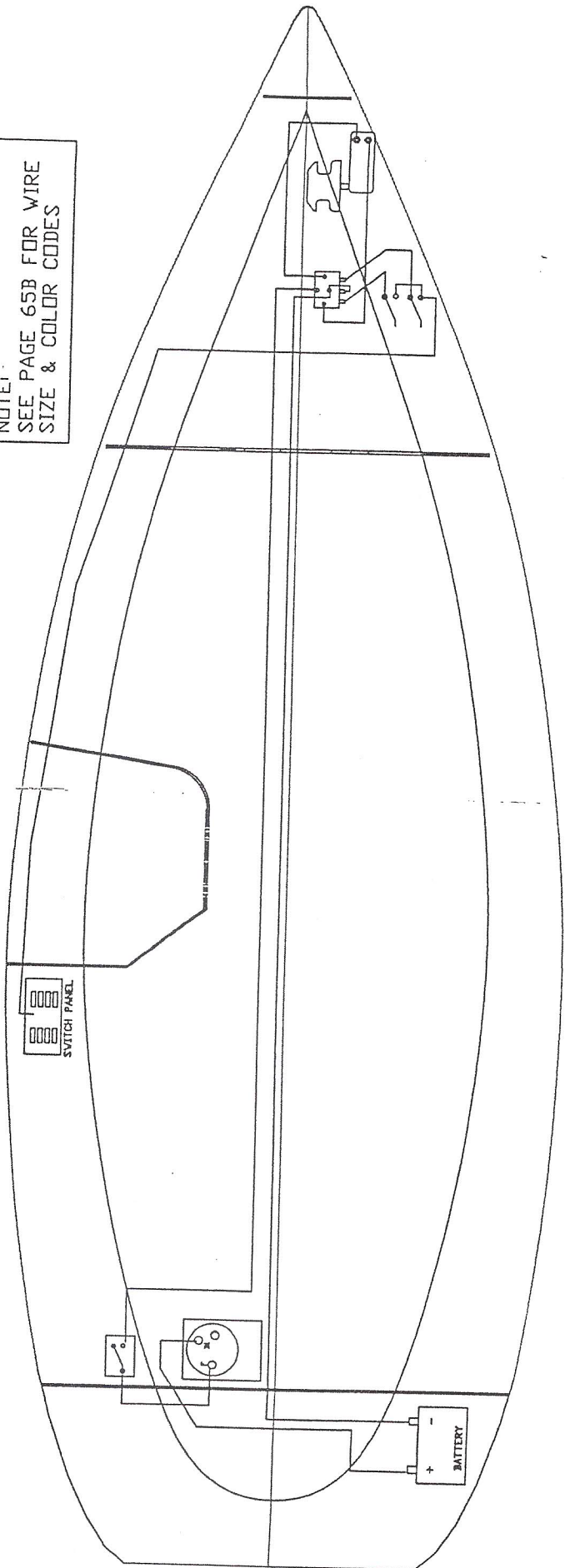

6GA. DRANGE & RED

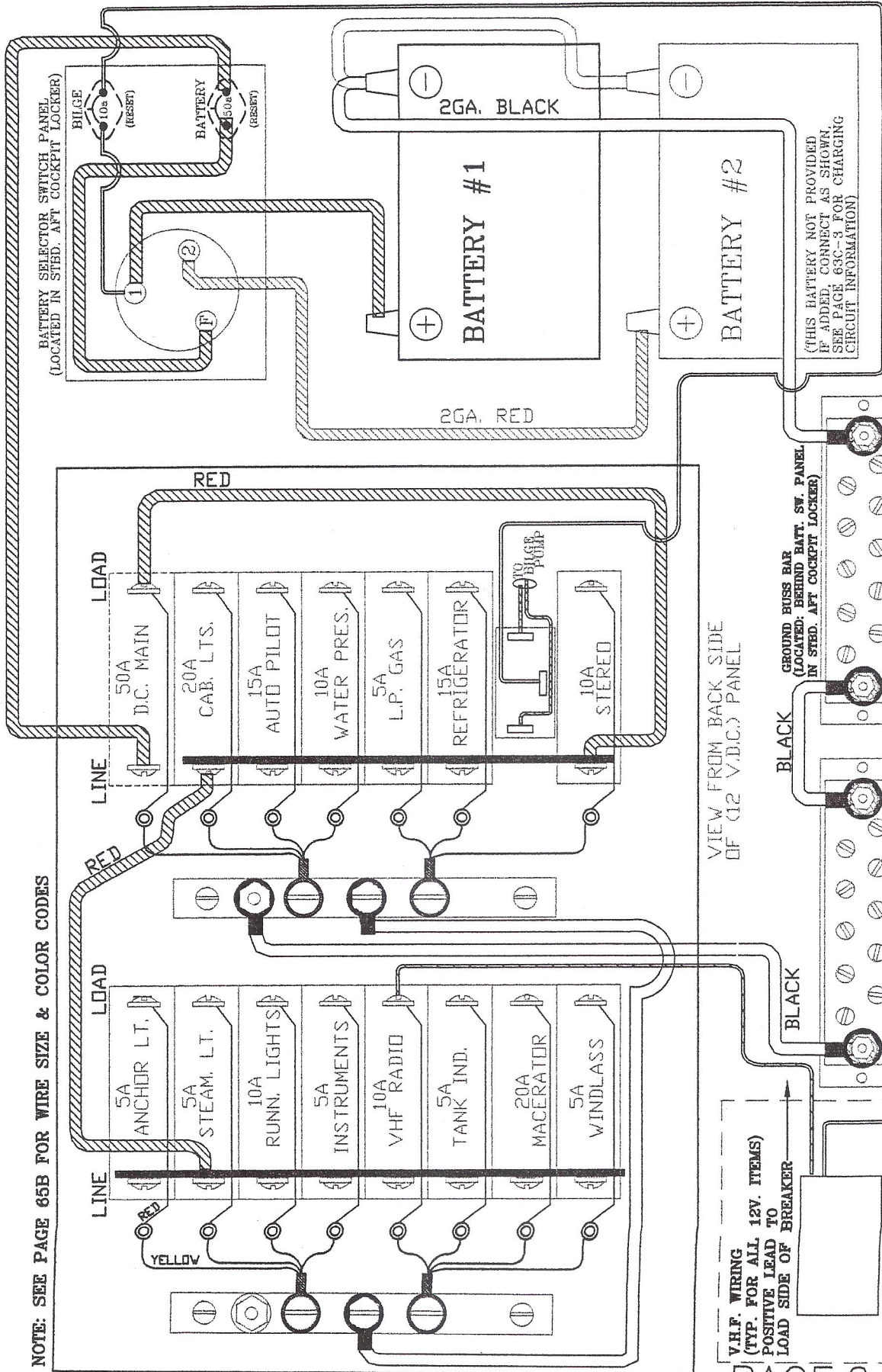

NOTE: SEE PAGE 65B FOR WIRE SIZE & COLOR CODES

V.H.F. WIRING  
(TYP. FOR ALL 12V. ITEMS)  
POSITIVE LEAD TO  
LOAD SIDE OF BREAKER

NEGATIVE LEAD TO  
GROUND BUSS BAR

VIEW FROM BACK SIDE  
OF (12 V.D.C.) PANEL

GROUND BUSS BAR  
(LOCATED: BEHIND BATT. SW. PANEL  
IN STD. AFT COCKPIT LOCKER)

GROUND BUSS BAR  
(LOCATED BEHIND DISTRIBUTION PANEL)

(THIS BATTERY NOT PROVIDED  
IF ADDED, CONNECT AS SHOWN.  
SEE PAGE 63C-3 FOR CHARGING  
CIRCUIT INFORMATION)

FIGURE TITLE: H310 12V.D.C. PANEL SCHEMATIC

REVISION NO.: NONE

DATE: 3/12/88

DESIGNED BY: ENGINEERING DEPT

HUNTER

6GA. ORANGE & RED  
 12V. POS. FROM BATTERY  
 SELECTOR SWITCH PANEL ("F" TERMINAL)

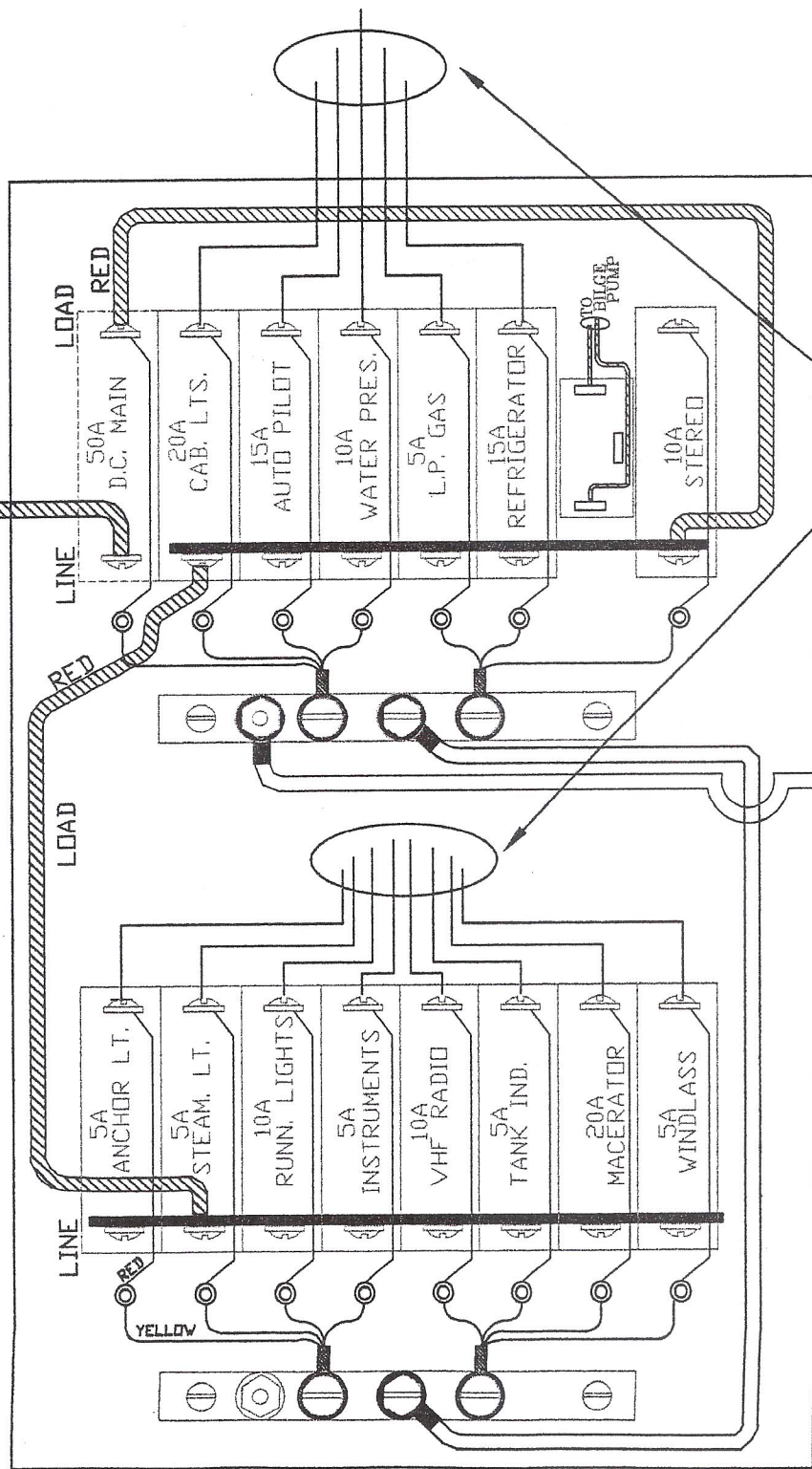

VIEW FROM BACK SIDE  
 OF (12 V.D.C.) PANEL

12V. COMPONENT POSITIVE LEADS  
 (SEE PAGE 65B FOR COLOR CODE & WIRE SIZE)

12V. COMPONENT  
 NEGATIVE LEADS

10GA. BLACK

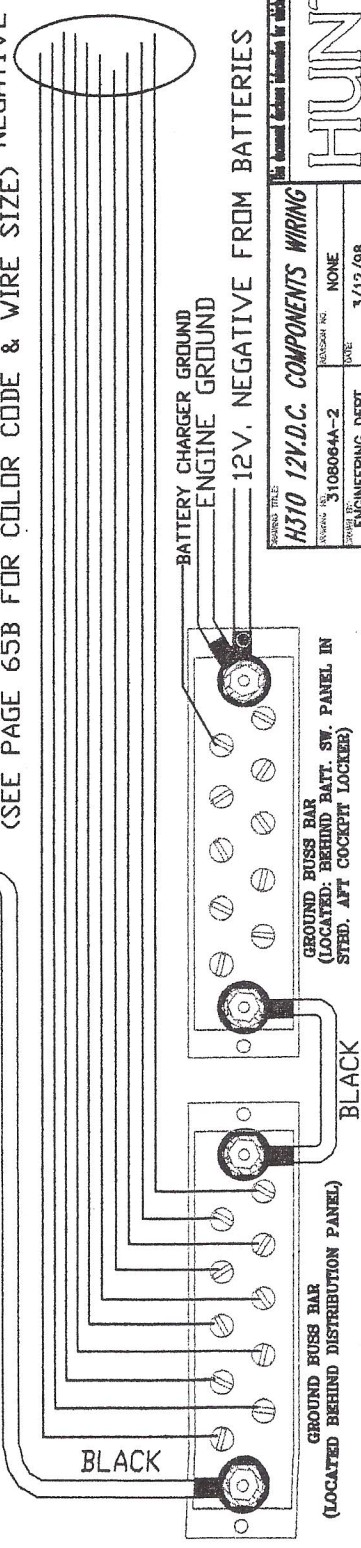

HUNTER  
 H310 12V.D.C. COMPONENTS WIRING  
 DRAWING NO. 3108064A-2  
 DATE 3/12/98  
 ENGINEERING DEPT  
 NONE

LEGEND

- DOME LIGHTS
- ⊙ HALOGEN LIGHTS
- ⊕ BOV LIGHT
- ⊞ READING LIGHTS
- WIRE RUNS
- ⊞ ON/OFF SWITCH

NOTE: SEE PAGE 65B FOR WIRE SIZE & COLOR CODE

EXAMPLE SWITCH PANEL WIRING (PARALLEL CIRCUITS)

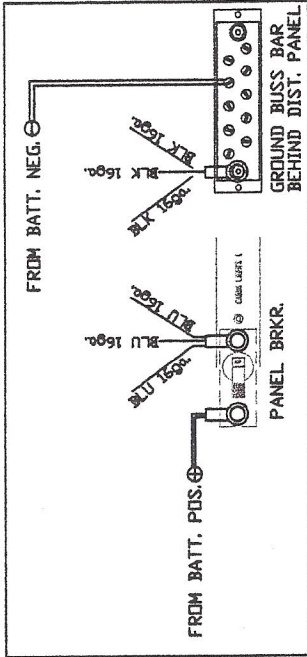

EXAMPLE LIGHT WIRING (PARALLEL CIRCUIT)

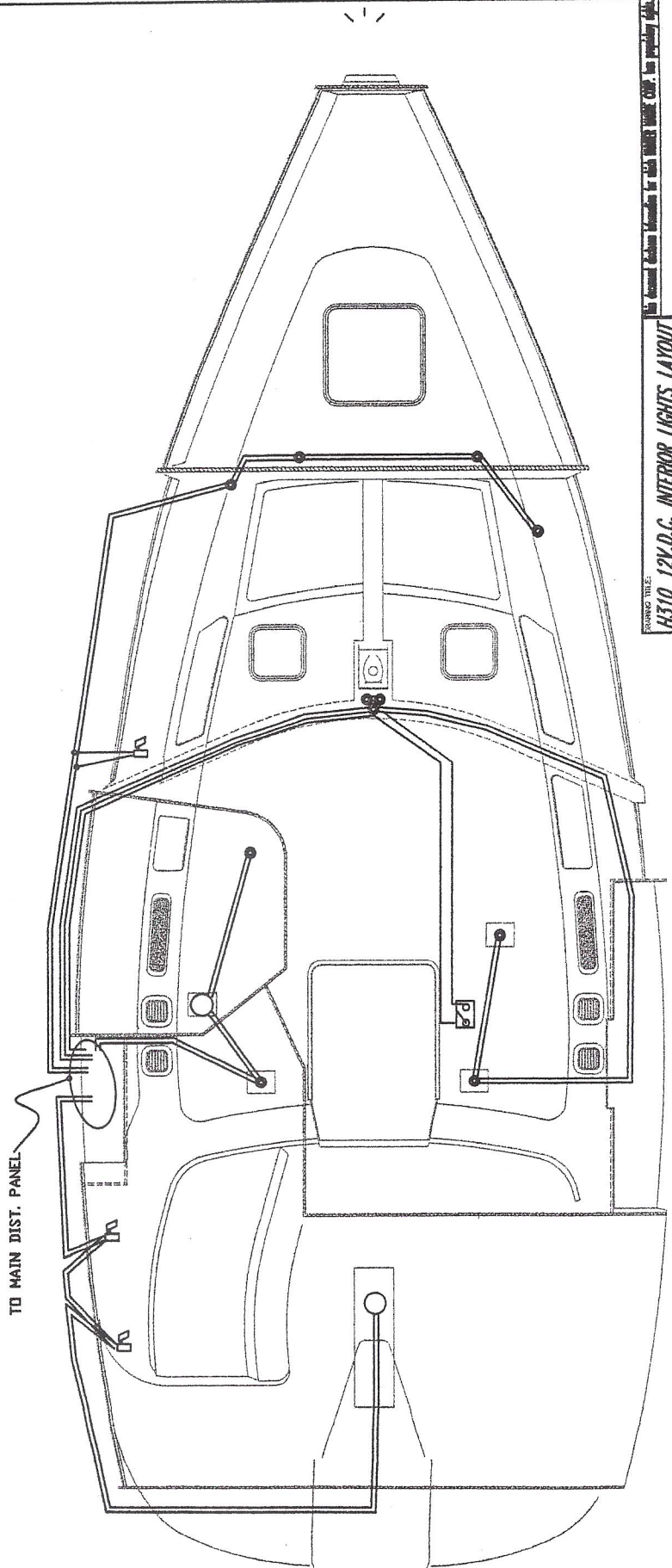
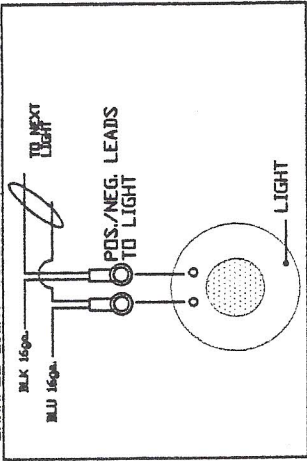

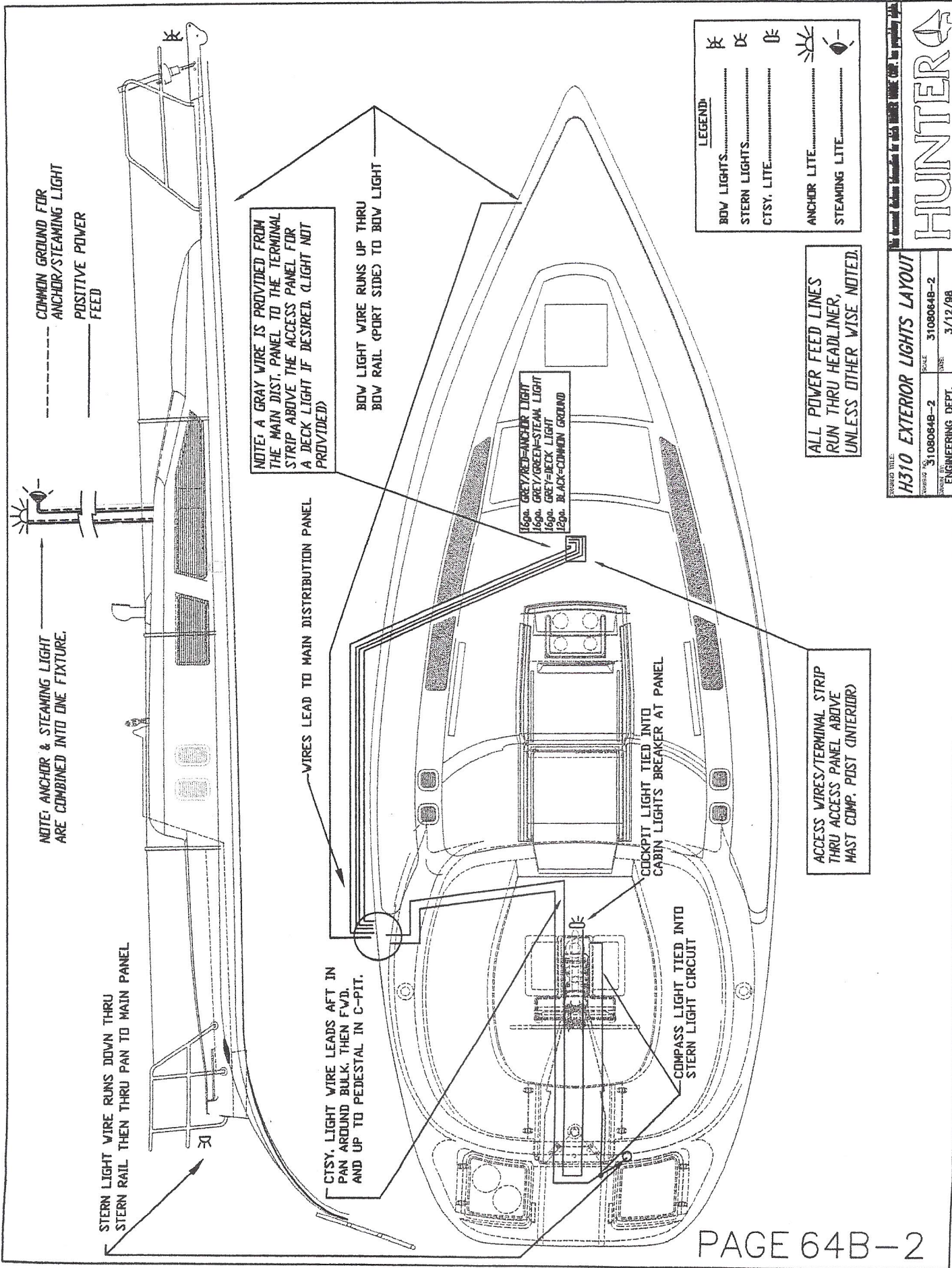

COMMON GROUND FOR ANCHOR/STEAMING LIGHT POSITIVE POWER FEED

NOTE: ANCHOR & STEAMING LIGHT ARE COMBINED INTO ONE FIXTURE.

STERN LIGHT WIRE RUNS DOWN THRU STERN RAIL THEN THRU PAN TO MAIN PANEL

NOTE: A GRAY WIRE IS PROVIDED FROM THE MAIN DIST. PANEL TO THE TERMINAL STRIP ABOVE THE ACCESS PANEL FOR A DECK LIGHT IF DESIRED. (LIGHT NOT PROVIDED)

BOW LIGHT WIRE RUNS UP THRU BOW RAIL (PORT SIDE) TO BOW LIGHT

WIRES LEAD TO MAIN DISTRIBUTION PANEL

CTSY. LIGHT WIRE LEADS AFT IN PAN AROUND BULK. THEN F.W.D. AND UP TO PEDESTAL IN C-PIT.

16ga. GREY/RED=ANCHOR LIGHT  
16ga. GREY/GREEN=STEAM LIGHT  
16ga. GREY=DECK LIGHT  
12ga. BLACK=COMMON GROUND

COCKPIT LIGHT TIED INTO CABIN LIGHTS BREAKER AT PANEL

COMPASS LIGHT TIED INTO STERN LIGHT CIRCUIT

ACCESS WIRES/TERMINAL STRIP THRU ACCESS PANEL ABOVE MAST COMP. POST (INTERIOR)

LEGEND:

	BOW LIGHTS.....
	STERN LIGHTS.....
	CTSY. LITE.....
	ANCHOR LITE.....
	STEAMING LITE.....

ALL POWER FEED LINES RUN THRU HEADLINER, UNLESS OTHER WISE NOTED.

PROJECT TITLE: **H310 EXTERIOR LIGHTS LAYOUT**

WORK NO: 3108064B-2

SCALE: 3108064B-2

DATE: 3/12/98

ENGINEERING DEPT.

**HUNTER**

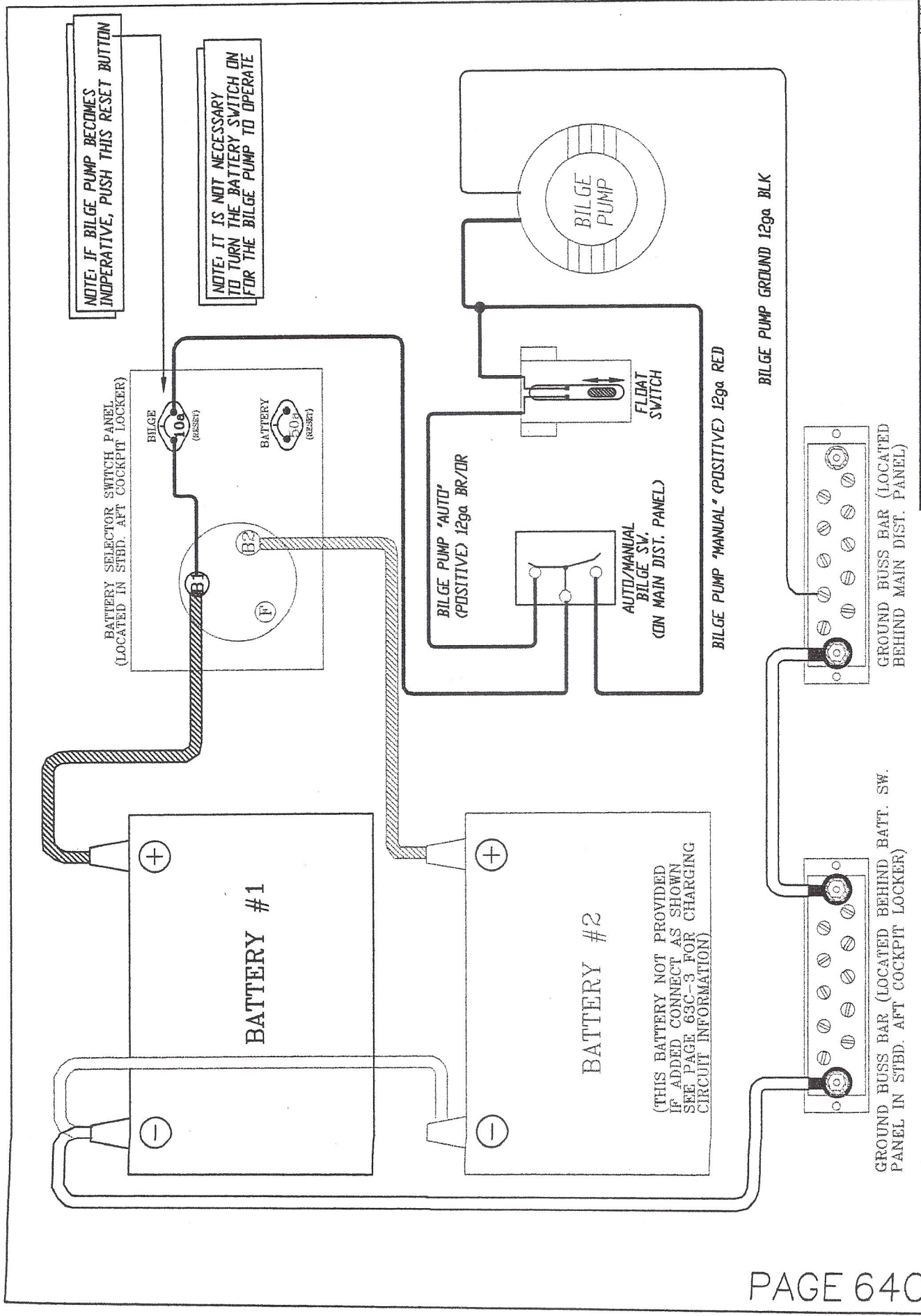

NOTE: IF BILGE PUMP BECOMES INOPERATIVE, PUSH THIS RESET BUTTON

NOTE: IT IS NOT NECESSARY TO TURN THE BATTERY SWITCH ON FOR THE BILGE PUMP TO OPERATE

**HUNTER**

**H310 BILGE SYSTEM SCHEMATIC**

REVISED TITLE: H310 BILGE SYSTEM SCHEMATIC

REVISION NO.: 310806-4C

DATE: 3/12/98

ENGINEERING DEPT.



DPT. WINDSPEED TRANSDUCER CABLE (THRU HEADLINER) TO TERMINAL STRIP

INSTRUMENTS  
POWER FEED  
FROM MAIN  
DISTRIBUTION PANEL

TRANSDUCERS/CABLES  
FOR KNOT & DEPTH INDICATORS  
ACCESS THRU MAIN BILGE & PORT MAIN BUNK COMP.

DPT. G.P.S. ANTENNA  
MOUNTS TO STERN RAIL

OPTIONAL G.P.S. REPEATER  
OPTIONAL WINDSPEED REPEATER

ALL LEADS RUN IN PAN TO HEAD, THEN UP  
TO BEAM IN HEADLINER, THEN TO INSTRUMENTS

PAGE 64D

PROJ. TITLE: **H310 INSTRUMENTS LAYOUT**

NO. 3108084D	SCALE: NTS
ENGINEERING DEPT.	DATE: 3/12/98

FOR GENERAL GUIDANCE ONLY. THIS DRAWING IS NOT TO BE USED FOR CONSTRUCTION WITHOUT THE APPROVAL OF THE PROJECT MANAGER.

**HUNTER**

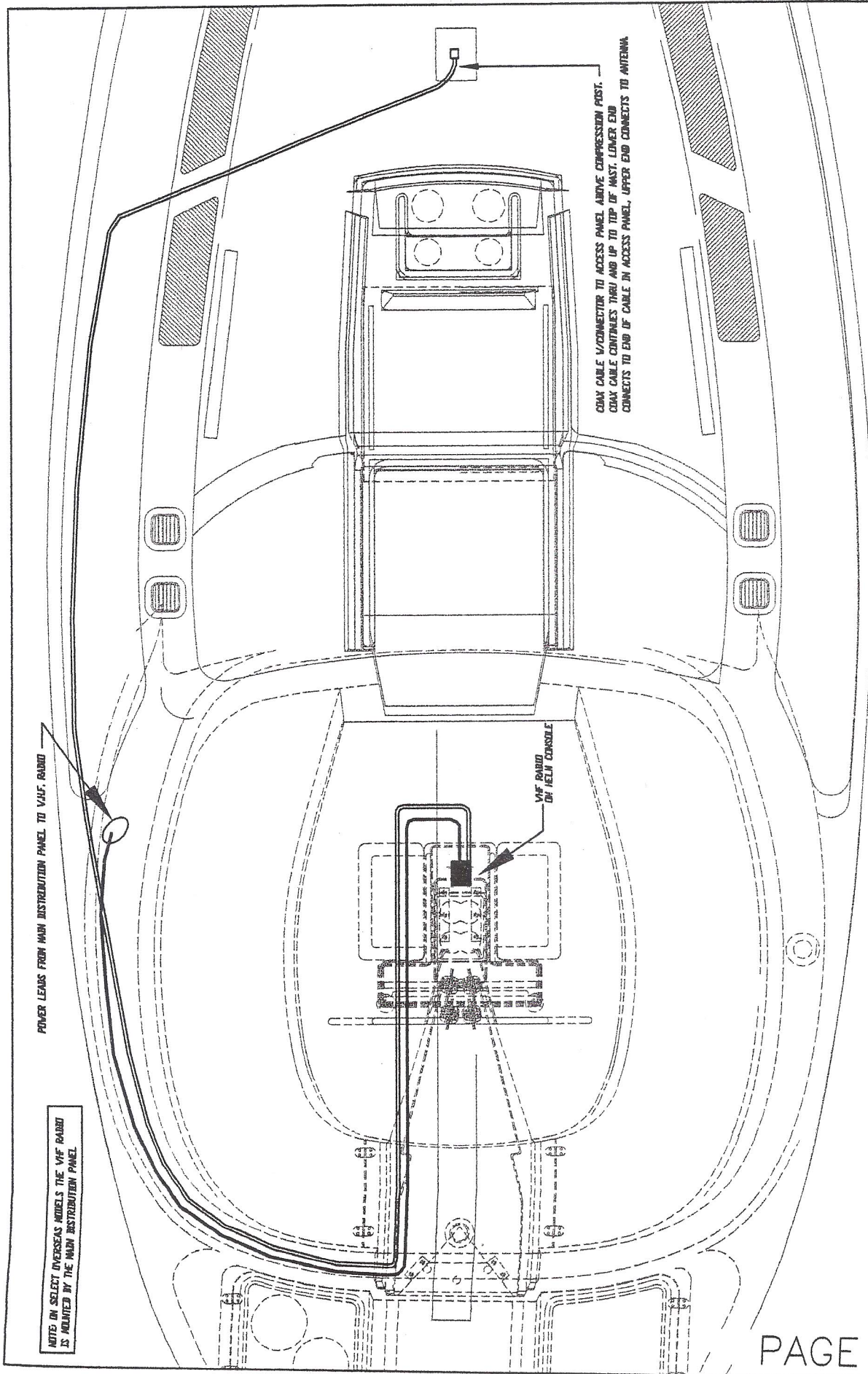

LINE RUNS FROM MAIN DIST. PANEL, DOWN, THEN AFT THRU PAN, UP & AROUND Q-BERTH BULKHEAD, FWD & UP TO RADIO.  
 POWER LEADS FROM MAIN DIST. PANEL, DOWN, THEN AFT THRU PAN, UP & AROUND Q-BERTH BULKHEAD, FWD & UP TO RADIO.  
 ANTENNA COAX LEAD FROM MAST STEP, CABLE RUNS THRU HEADLINER AFT INTO COCKPIT LOCKER, THEN FWD BETWEEN DECK & HEADLINER THEN UP TO RADIO.

PROJECT TITLE: **H310 VHF RADIO LAYOUT**

DESIGN NO.	310B084E	SCALE	NTS
DATE	3.13.98	ENGINEERING DEPT.	

HUNTER

SECTION 63B...OPTIONAL AIR COND. SYSTEMS

BASIC OPERATING INSTRUCTIONS:

- ① CONNECT SHORE POWER CORD
- ② CHECK AIR COND. SEA STRAINER, (Q-BERTH COMP.) CLEAN IF NECESSARY
- ③ OPEN RAW WATER PICKUP SEACOCK Q-BERTH BUNK COMP.
- ④ TURN ON A.C. MAIN BREAKER ON A.C. DISTRIBUTION PANEL
- ⑤ TURN ON AIR COND. BREAKER
- ⑥ TURN ON UNIT AT E.C.U. (ENVIRONMENT CONTROL UNIT) DISPLAY PANEL AND SET TEMP.

NOTE:

WHEN USING AIR COND. SYSTEM WITH OTHER APPLIANCE/S  
"POWER UP" THE AIR COND. FIRST.

IF THERE IS NO POWER AT PANEL WHEN CONNECTED  
TO SHORE POWER, CHECK MAIN BREAKER IN Q-BERTH HEADLINER, PORT SIDE

SEE MARINE AIR MANUAL FOR DETAILED OPERATING  
PROGRAMMING/TROUBLESHOOTING INSTRUCTIONS

- ① AIR COND. COMPRESSOR (INSIDE GALLEY)
- ② 5" (127.0mm) AC DUCT
- ③ 3" (76.2mm) AC DUCT
- ④ VENTS
- ⑤ 5/8" (15.9mm) RAW WATER DISCHARGE
- ⑥ MAIN DISTRIBUTION PANEL
- ⑦ SEA STRAINER
- ⑧ RAW WATER INTAKE (SEACOCK) 3/4" (19.1mm)
- ⑨ CIRCULATION PUMP
- ⑩ ENVIRONMENT CONTROL UNIT (ECU)
- ⑪ CONTROL BOX

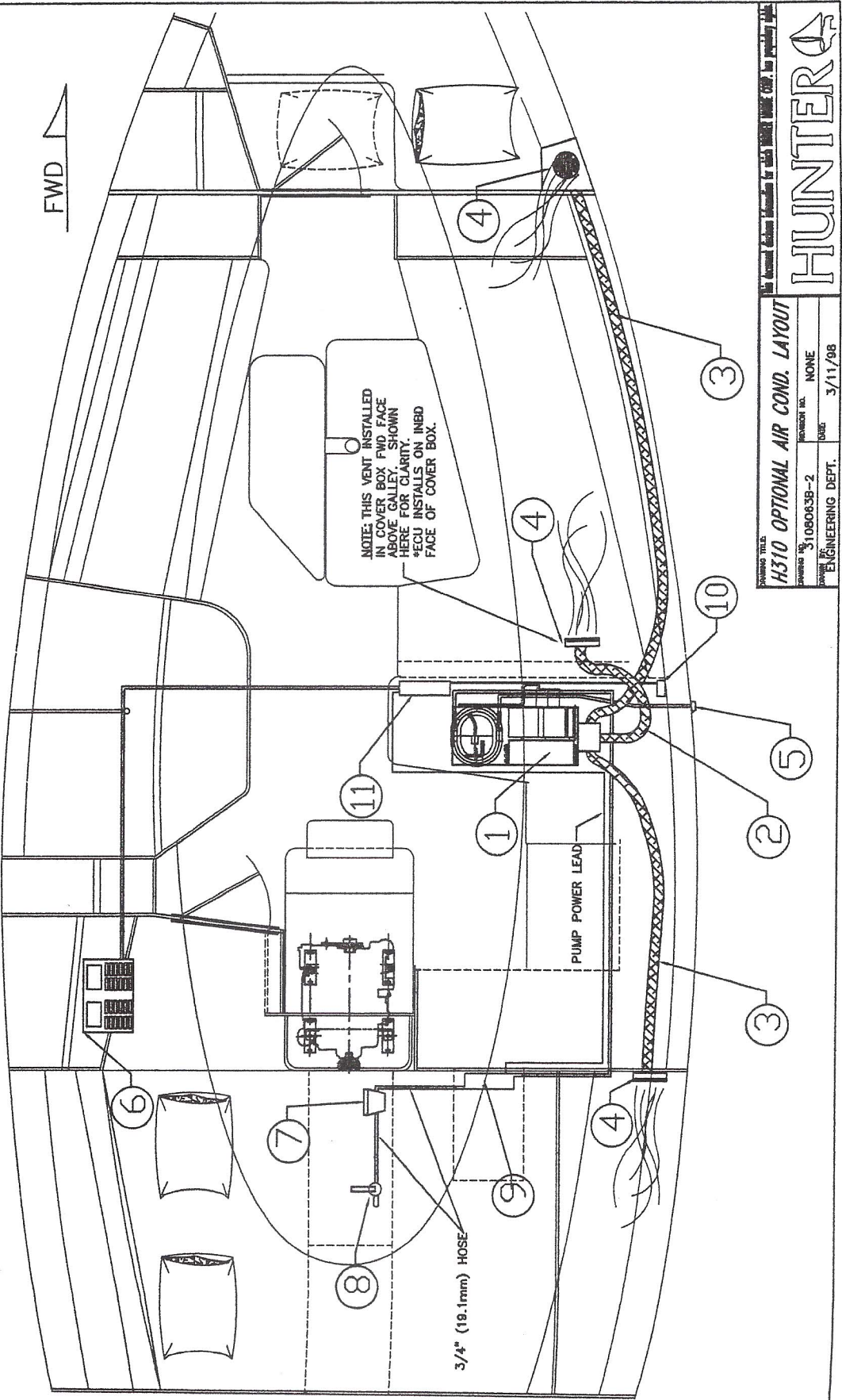

DRAWING TITLE  
**H310 OPTIONAL AIR COND. LAYOUT**

DRAWING NO. 3108063B-2      REVISION NO. NONE

DESIGNED BY      DATE 3/11/06

ENGINEERING DEPT.

HUNTER

SECTION 64F...REFRIGERATION SYSTEM (OPTIONAL)

BASIC OPERATING INSTRUCTIONS:

- ① TURN ON HOUSE BATTERY SWITCH (IN STBD AFT C.PIT LOCKER)
- ② TURN ON MAIN D.C. BREAKER AT MAIN BREAKER PANEL
- ③ TURN ON REFRIG. BREAKER
- ④ SET THERMOSTAT TO DESIRED TEMP.

NOTE:

IF LEAVING UNIT ON WHEN AWAY FROM BOAT  
BE SURE SHORE POWER CABLES ARE CONNECTED AND  
BATTERY CHARGER IS ON TO PREVENT BATTERY DRAIN.

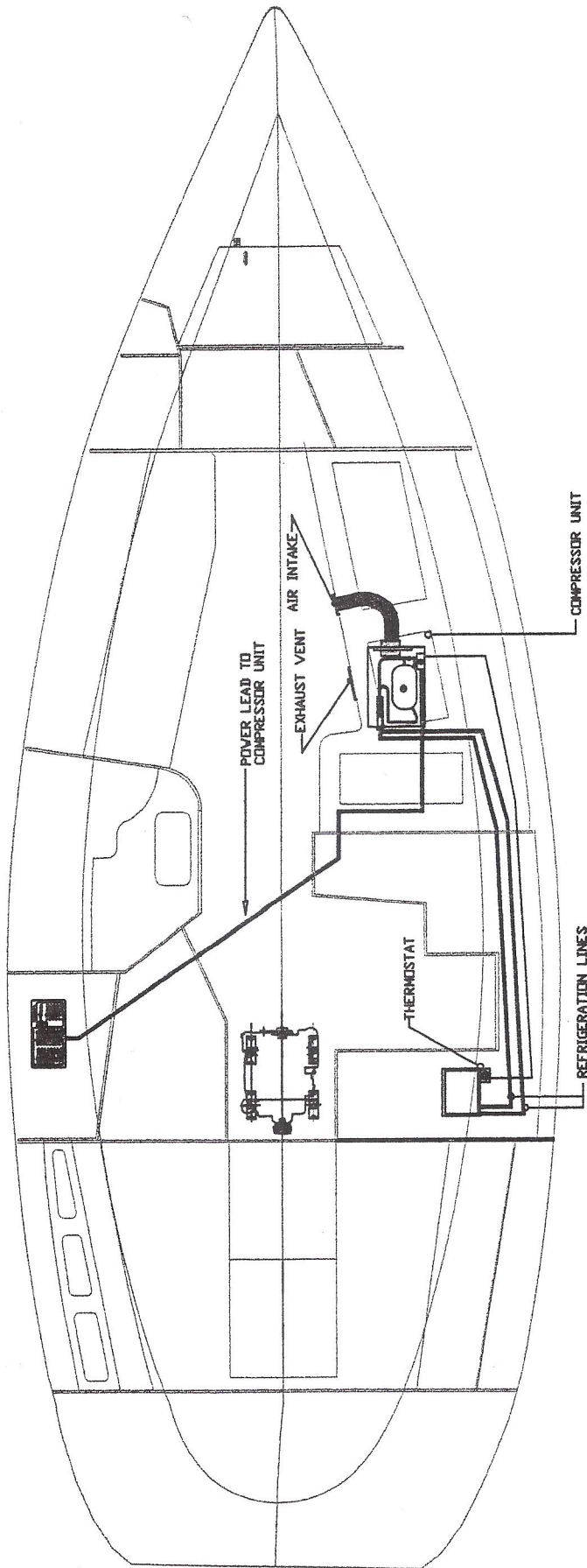

HUNTER  
 H310 (OPTIONAL) REFRIGERATION LAYOUT  
 DRAWING NO. 3108064F-2  
 SCALE NTS  
 DATE 3/13/98  
 ENGINEERING DEPT.

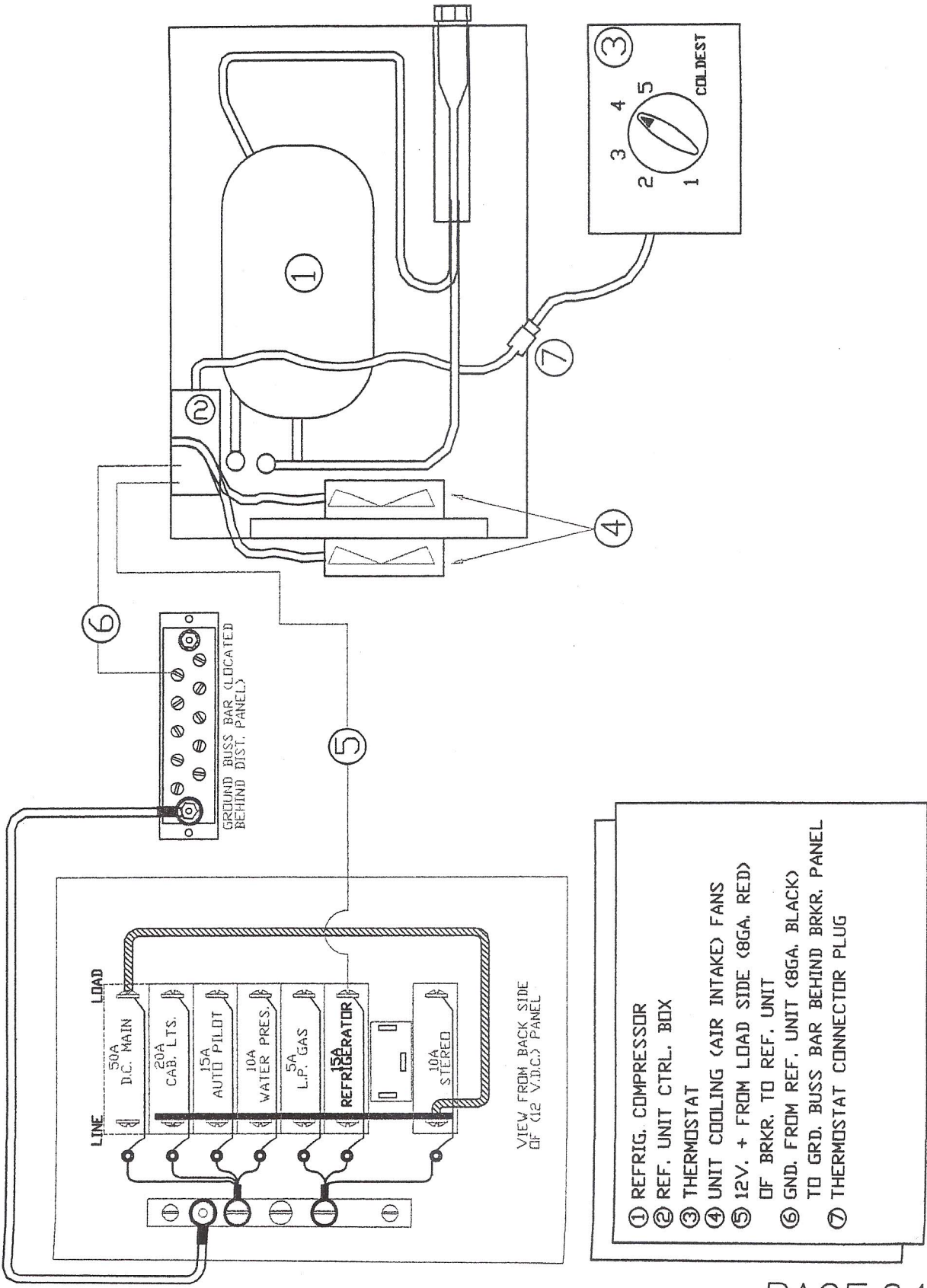

- VIEW FROM BACK SIDE OF (12 V.D.C.) PANEL
- ① REFRIG. COMPRESSOR
  - ② REF. UNIT CTRL. BOX
  - ③ THERMOSTAT
  - ④ UNIT COOLING (AIR INTAKE) FANS
  - ⑤ 12V. + FROM LOAD SIDE (8GA. RED) OF BRKR. TO REF. UNIT
  - ⑥ GND. FROM REF. UNIT (8GA. BLACK) TO GRD. BUSS BAR BEHIND BRKR. PANEL
  - ⑦ THERMOSTAT CONNECTOR PLUG

NOTE: SEE REFRIGERATION MANUAL FOR CONTROL BOX HOOKUP DETAILS

HUNTER  
 H310 REFRIGERATION SCHEMATIC  
 DRAWING NO. 3108064F-3  
 REVISION 13. NONE  
 DATE 3/13/88  
 ENGINEERING DEPT.

## SECTION 64G...(OPTIONAL) WINDLASS SYSTEM

### BASIC OPERATING INSTRUCTIONS:

#### LOWERING ANCHOR....

- ① TURN ON BATTERY SWITCH
- ② TURN ON WINDLASS BRKR. ON MAIN D.C. BRKR. PANEL.
- ③ PUSH WINDLASS 'DOWN' BUTTON (GREY) ON FOREDECK AFT OF ANCHOR WELL.

NOTE: 'BUMP' SWITCH UNTIL ANCHOR CLEARS ANCHOR ROLLER AND HULL BEFORE LETTING ANCHOR DOWN FREELY.

#### RAISING ANCHOR....

- ① START BOAT ENGINE, THIS WILL ALLOW CONTROL OF BOAT WHEN ANCHOR BECOMES FREE, AS WELL AS REDUCING LOAD ON BATTERY
- ② SAME AS STEP #2 OF LOWERING ANCHOR
- ③ PUSH WINDLASS 'UP' BUTTON (RED) BEING CAREFUL AS THE ANCHOR APPROACHES THE HULL AND ANCHOR ROLLER) UNTIL THE ANCHOR RESTS IN THE STEMHEAD PROPERLY.

NOTE: IF IT APPEARS THERE IS NO POWER TO THE WINDLASS, CHECK RESET BRKR. IN STBD. AFT COCKPIT COMP. IF WINDLASS BECOMES INOPERABLE ELECTRICALLY, A MANUAL WINCH HANDLE IS SUPPLIED, SEE THE 'HORIZON WINDLASS MANUAL' SUPPLIED IN YOUR OWNERS MANUAL PACKAGE FOR INSTRUCTIONS.



FOR ALL INFORMATION REGARDING HUNTER BOATS, VISIT OUR WEBSITE AT [WWW.HUNTERBOATS.COM](http://WWW.HUNTERBOATS.COM)

# HUNTER

FIGURE TITLE: **H310 WINDLASS (OPTIONAL) LAYOUT**

DESIGN NO.	3108064G-2	SCALE	NTS
ISSUED BY	ENGINEERING DEPT.	DATE	3/13/98

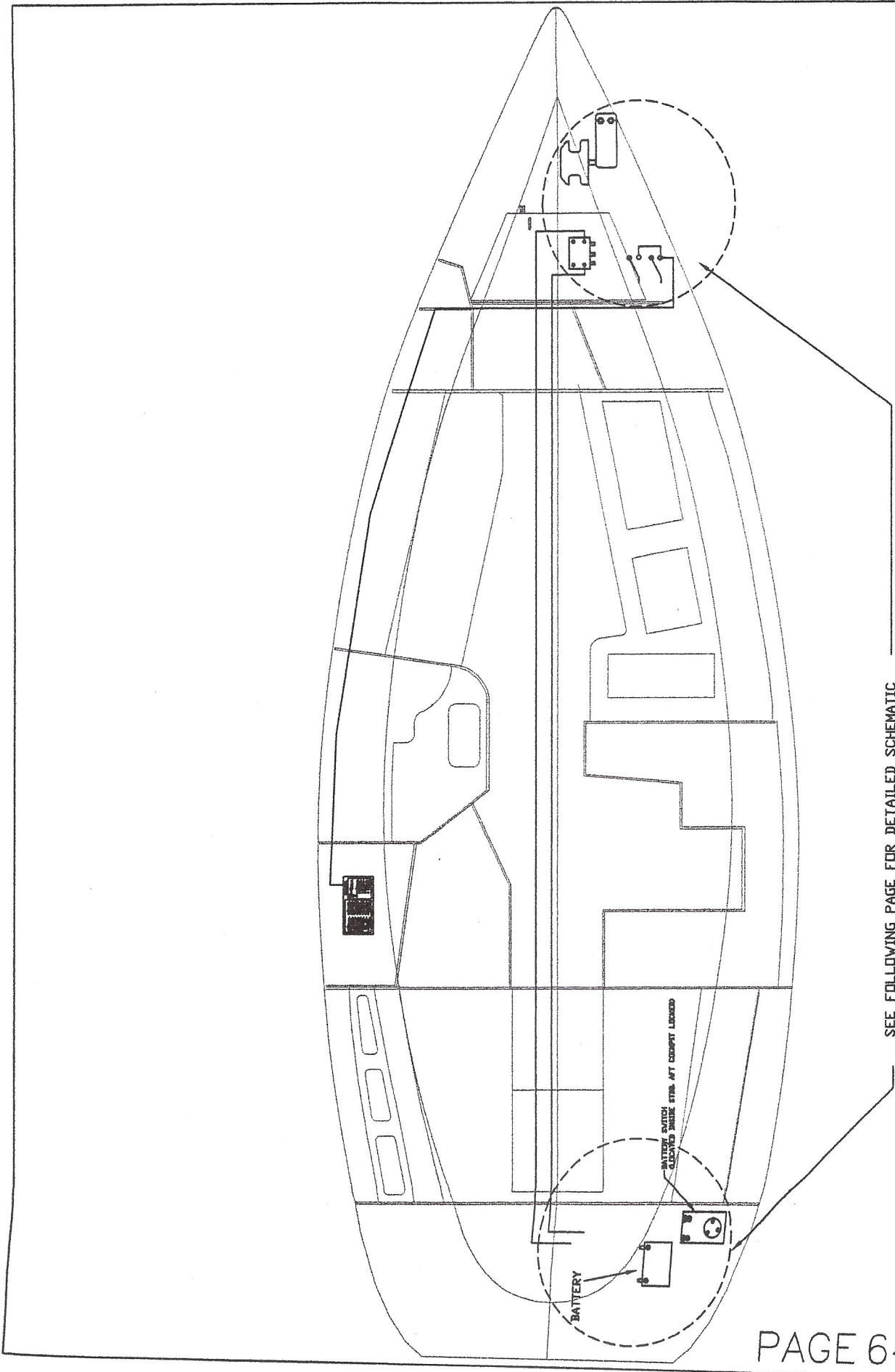

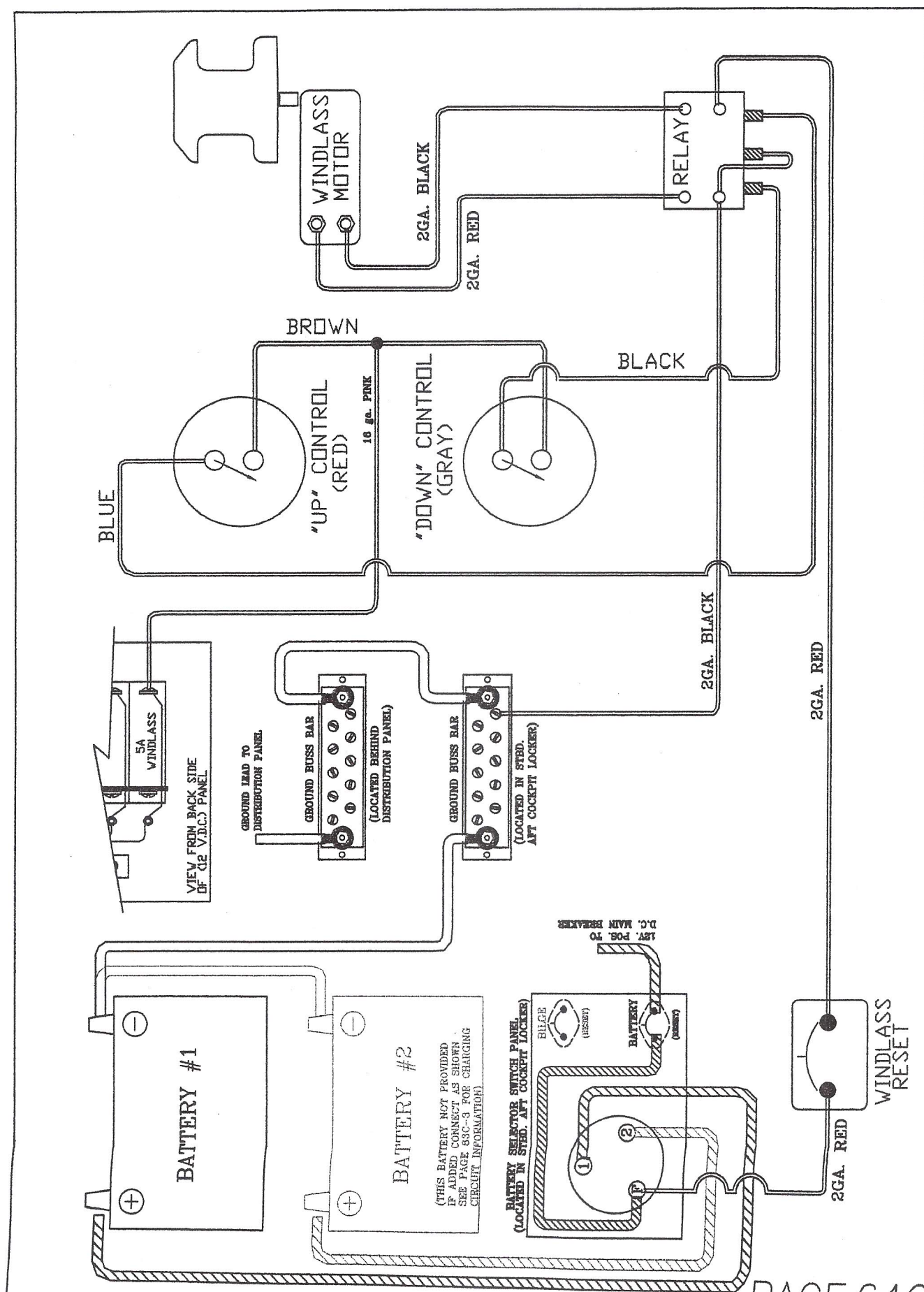

CHASE TUBE IN PORT HEADLINER  
 RUNS FROM PT. AFT COCKPIT LOCKER  
 FWD. TO MAIN DIST. PANEL CABINET

CHASE TUBES IN MAIN HEADLINER BEAM  
 ACCESS PANEL ABOVE COMPRESSION POST

BUILT IN WIRE CHASE IN HEADLINER  
 AROUND HEAD BULKHEAD RECEIVERS  
 INSTRUMENT LEADS RUN THRU THIS CHASE;  
 ACCESS PANEL ABOVE HEAD DOOR

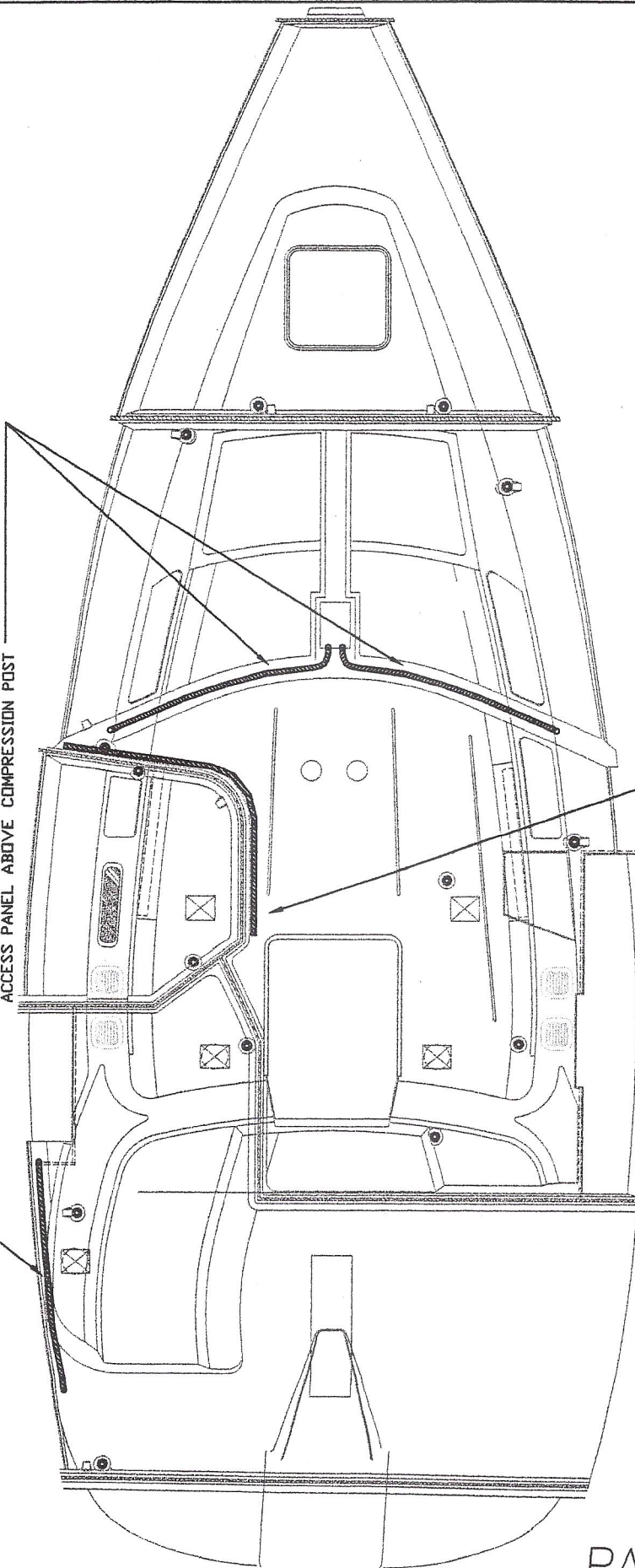

**BATTERY SWITCH CONNECTIONS**

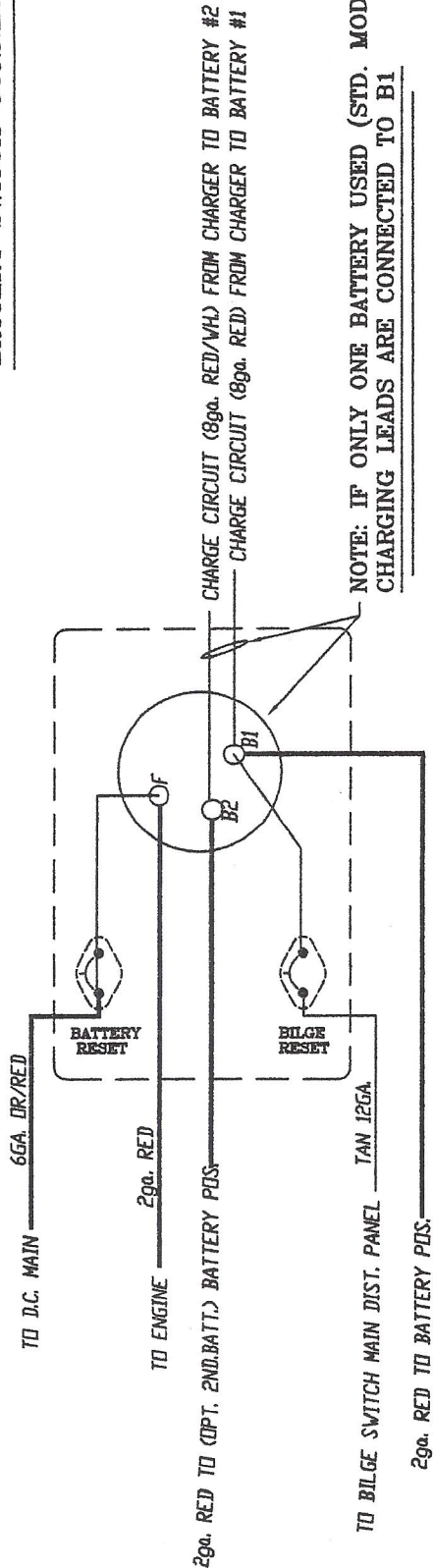

NOTE: IF ONLY ONE BATTERY USED (STD. MODEL) BOTH CHARGING LEADS ARE CONNECTED TO B1

**SHORE POWER CONNECTIONS**

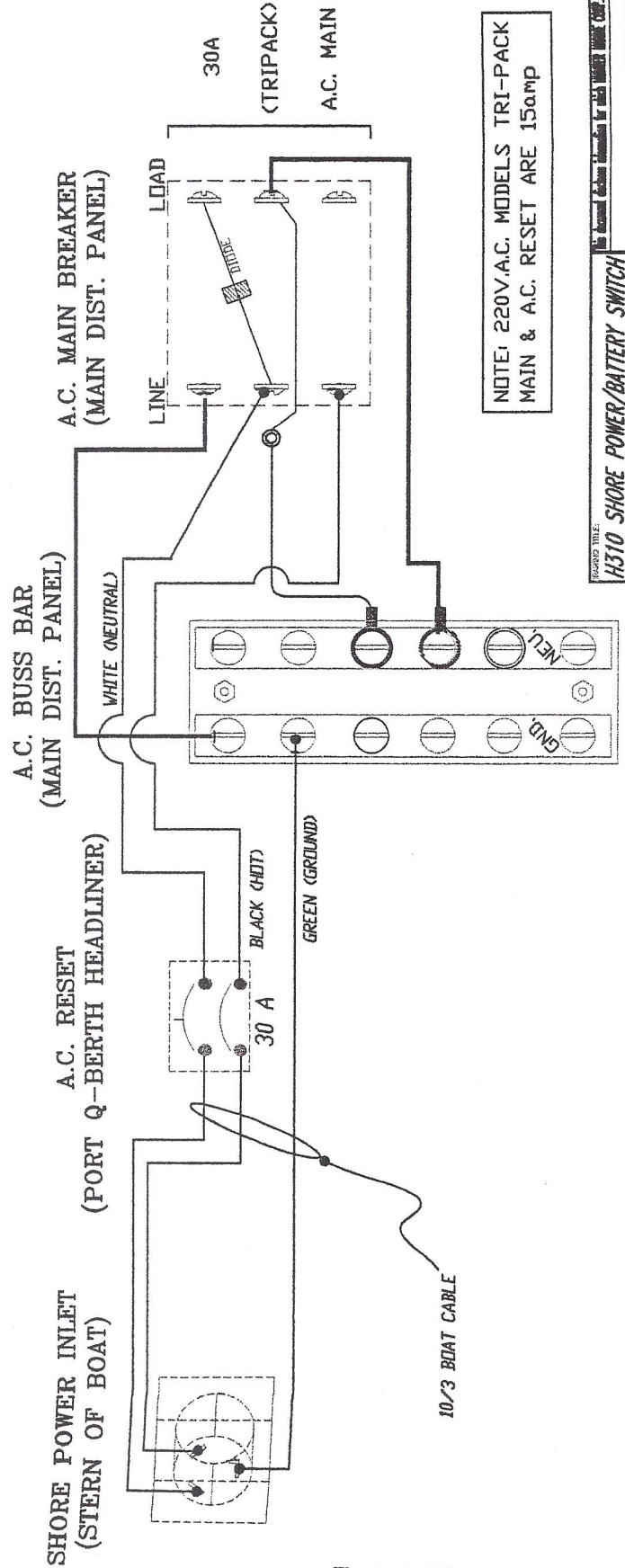

NOTE: 220V.A.C. MODELS TRI-PACK MAIN & A.C. RESET ARE 15amp

FIGURE TITLE: H310 SHORE POWER/BATTERY SWITCH

SCALE: NTS

ENGINE NO: 3108065A

DATE: 3/23/88

ENGINEERING DEPT.

**HUNTER**

ELECTRICAL WIRING INFO.			ELECTRICAL CABLE INFO.		
12V. ONLY			12V. & 110V.		
EL. COMP.	GA. WIRE	COLOR CODE	EL. COMP.	GA. WIRE	COLOR CODE
INSTMTS.	22GA.	RED/YEL/SHIELD	BAT. CABLES	2/0	RED & BLK
ANC. LITE	16 GA.	GRAY / RED & - *	ENG. ST. CAB.	2 GA.	RED & BLK
CAB. LITE	16 GA.	BLUE & BLK	HAL. WINCH "	2 GA.	RED & BLK
CTSY LITE	16 GA.	BLU/WH & BLK	WDLS. CABLE	2/0	RED & BLK
DECK LITE	16 GA.	GRAY & - *		↑ (12 V) ↑	
FANS	16 GA.	WH & BLK			
RUN. LITE	16 GA.	GRAY/WH & BLK	SH. POWER		
SPEAKERS	16 GA.	YEL & BLK	INVERTER	10/3	BOAT CABLE
SPEAKERS	16 GA.	BRN & BLK	AIR COND.	(110V)	NOTE: EURD. MODELS = 220 V.
STEAMING	16 GA.	GRAY/GRN & - *			
STERED	16 GA.	RED & YEL & BLK	AC. RELAY		
VHF RADIO	16 GA.	RED/WHI & BLK	BAT. CHGR		
WINDLASS	16 GA.	PINK	MICRO.	14/3	BOAT CABLE
L.P. SYS.	14/2	BOAT CABLE	OUTLETS	(110V)	NOTE: EURD. MODELS = 220 V.
TANK IND.	14/2	BOAT CABLE	WATER HTR.		
SHWR. SUMP	12GA.	BRN/YEL & BLK			
SHWR. SUMP	12GA.	BRN/BLK & BLK			
WAT. PUMP	12 GA.	BROWN & BLK			
MACERATOR	10GA.	BRN/WH & BLK			
FREEZER	8 GA.	RED/WH & BLK			
FRIDGE	8 GA.	RED/BLK & BLK			
BILGE PUMP	16GA.	BRN/RED & BRN/DR & BLK			
NOTE: * = (1) 12 GAUGE CABLE (BLACK) FOR - ANC./ DECK/ STEAMING LIGHTS					

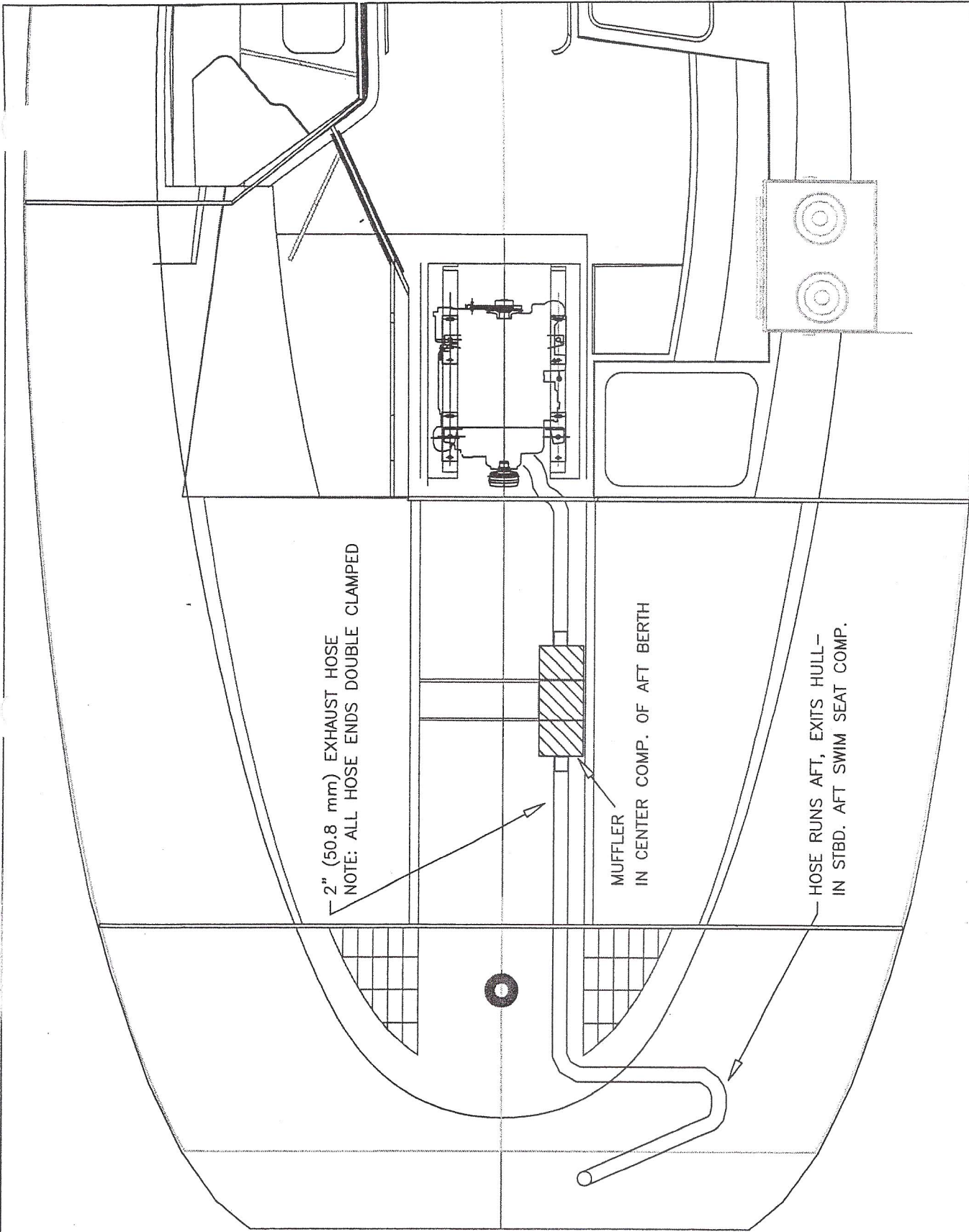

2" (50.8 mm) EXHAUST HOSE  
 NOTE: ALL HOSE ENDS DOUBLE CLAMPED

MUFFLER  
 IN CENTER COMP. OF AFT BERTH

HOSE RUNS AFT, EXITS HULL—  
 IN STBD. AFT SWIM SEAT COMP.

VIEW  
STBD. LOOKING PORT

VIEW  
PORT LOOKING STBD.

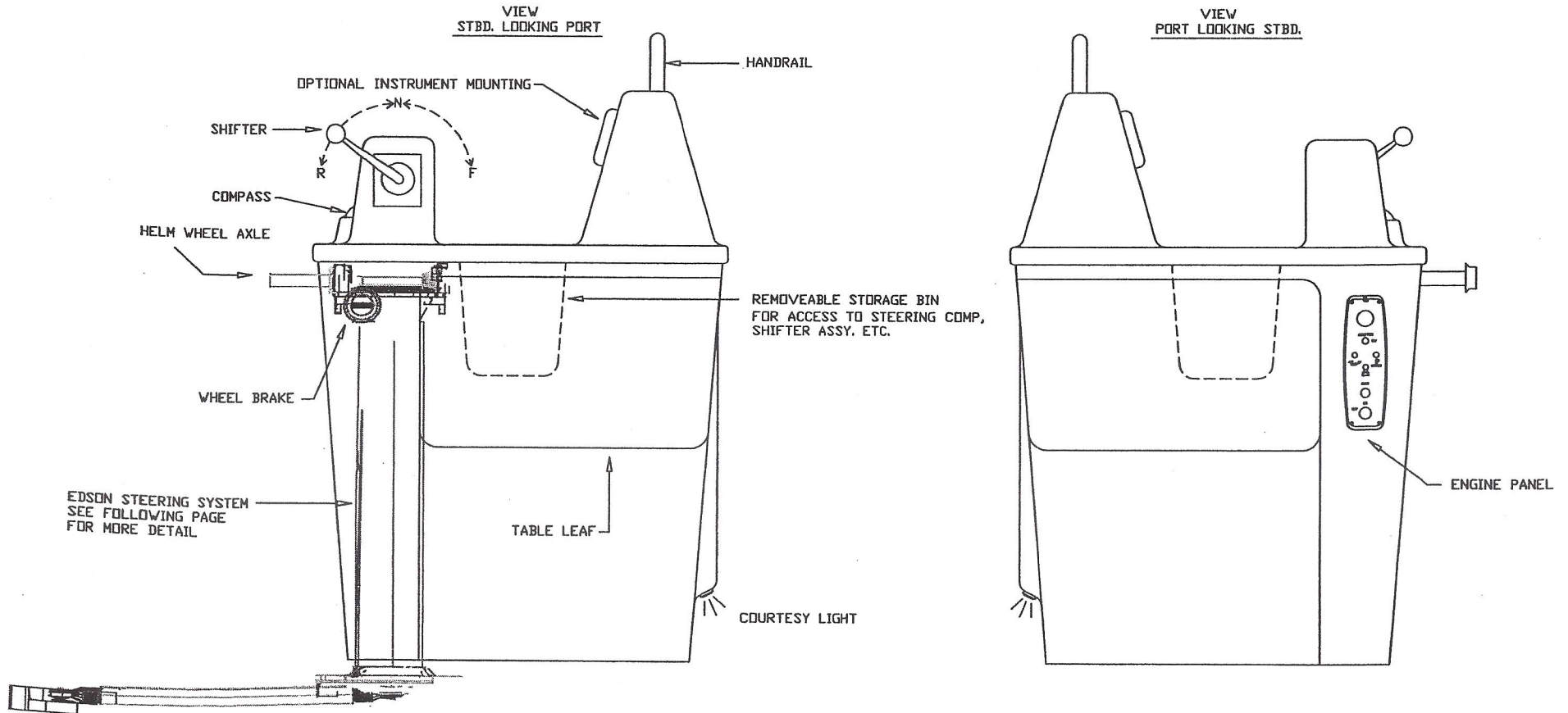

PAGE 67A

STEERING CONSOLE LAYOUT

**HUNTER** 

H-310 STEERING SYSTEM  
DRAWING # 3108067A

IMPORTANT:

SEE EDSON STEERING MAINTENANCE UNDER "MAINTENANCE"  
FOR A COMPLETE DESCRIPTION OF STEERING COMPONENTS  
AND VITAL ROUTINE MAINTENANCE PROCEDURES.

PLAN VIEW

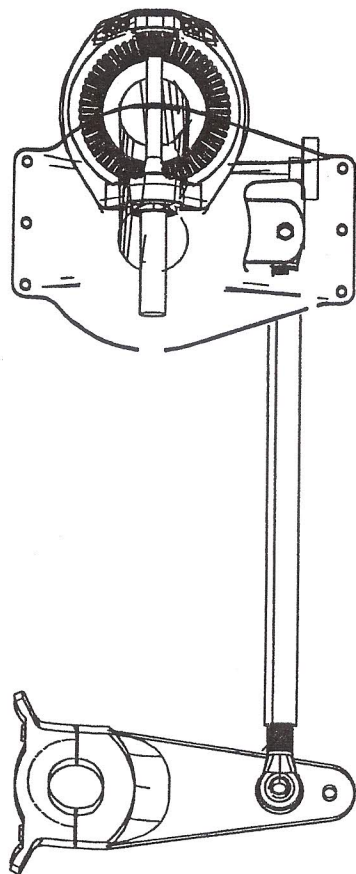

NOTE: THIS UNIT IS INSIDE  
COCKPIT CONSOLE, CONSOLE  
NOT SHOWN FOR CLARITY

ISO VIEW

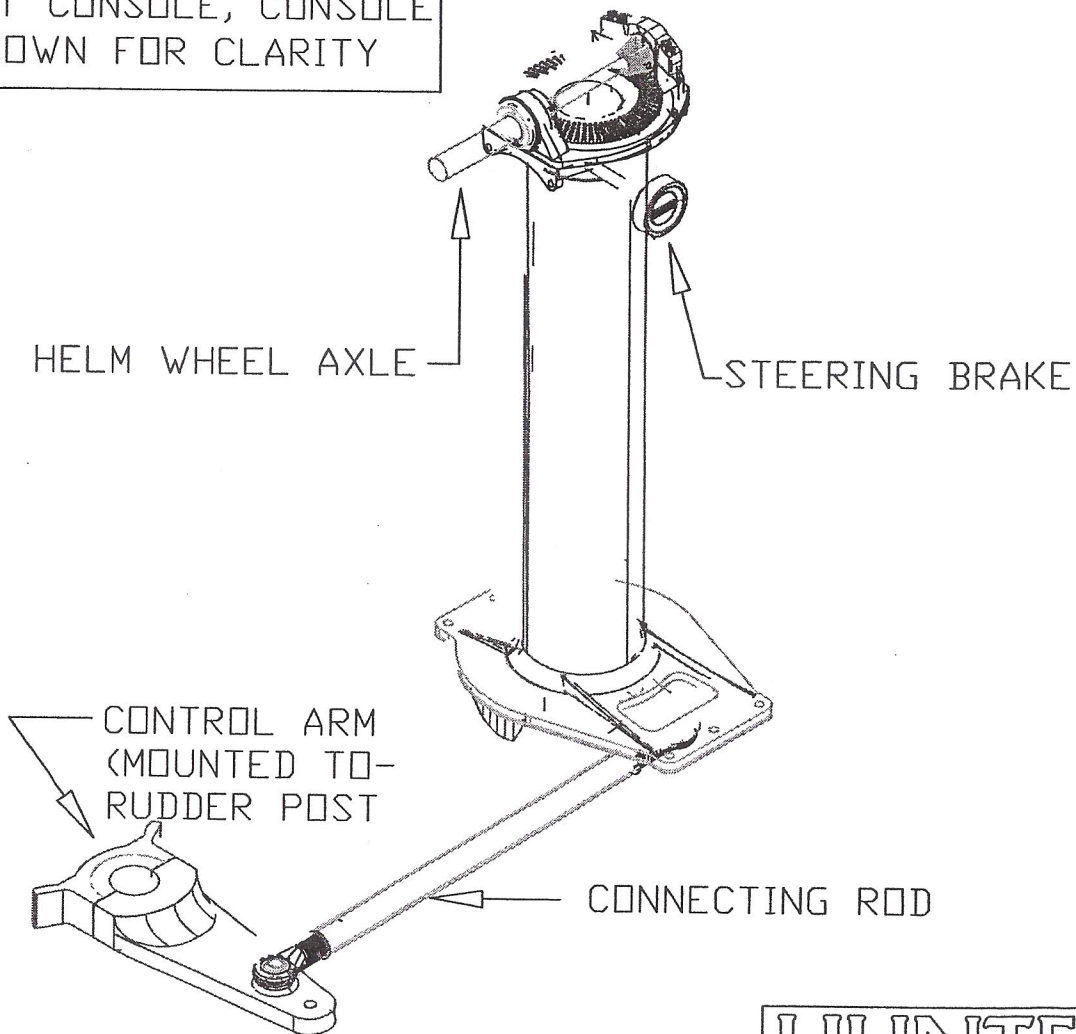

H-310 STEERING LAYOUT

**HUNTER**   
H-310 STEERING SYSTEM  
DRAWING # 3108067B



Steering Specifications

Length Overall	31' - 0"
Length Waterline	28' - 7"
Rudder Area	8.75 sq.ft.
Wheel Diameter	28 Inches
Rudder Travel	72 Degrees
Offset Angle	4 Degrees
Wheel Travel	1.8 Turns - Lock to Lock
Equivalent Tiller Length	8 Feet

Steerer:

Edson Fig. 470-5

- 5 1/4" Output Lever - #B-643
- 8" Tiller Arm - #B-676
- 37" Tie Rod - #B-680
- 2 Part Brake Assembly

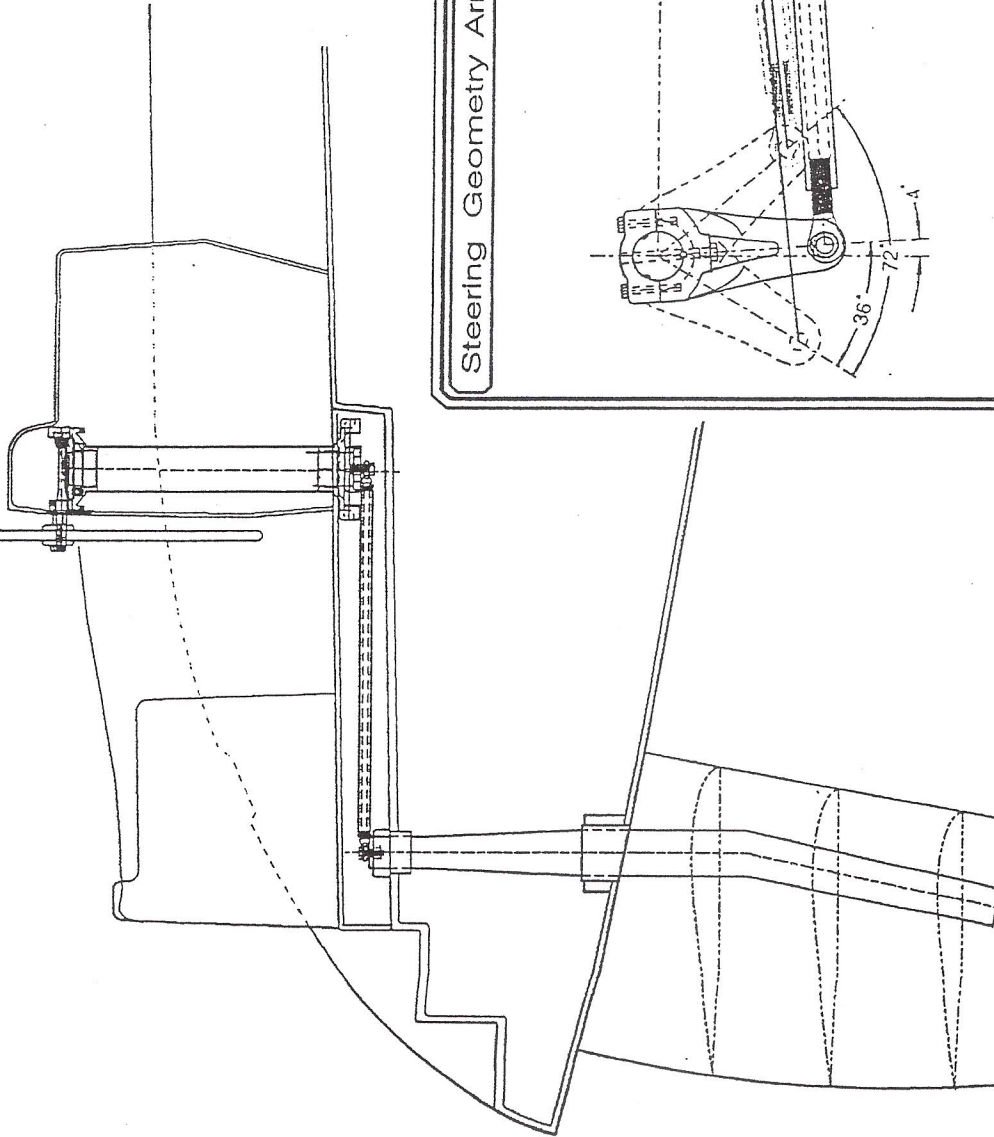

Steering Geometry Arrangement

1/6 th Size

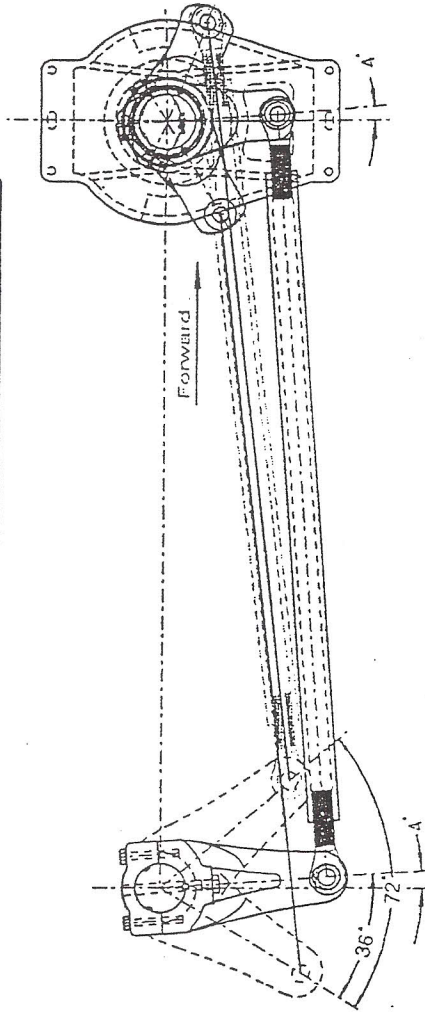

**Edson**  
INTERNATIONAL

EDSON CORPORATION  
116 Dunstable Boulevard  
New Bedford, MA 01908-1908  
(508) 866-5771 Fax: (508) 866-5161

Hunter 310 Steering System

Scale  
1" = 1'-0"  
Date  
April 7 th, 1997

Drawn by  
RWB

Checked by  
RWB

S-96-2498

