

HUNTER OWNER'S MANUAL

TABLE OF CONTENTS

<i>INTRODUCTION</i>	<i>PAGE</i>
• Welcome to Hunter Marine Family.....	III
• Hunter Warranty.....	3.1-3.6
• Brief History.....	5
• Glossary of Sailing Terms.....	6-9
• Explanation of Symbols and Labels.....	10
 <i>GENERAL HANDLING AND OPERATION</i>	
• Safe Boating Tips.....	11-12
• Preliminary Care and Inspection Worksheet.....	13A
• Pre-Departure Check List.....	13B
• Certification Details.....	13C
• Float Plan.....	14
• After Sailing Check List.....	15
• Docking and Anchoring.....	16
• Mast Raising and Lowering System.....	17
• Launching and Retrieving Procedures.....	18
• Getting Ready to Sail.....	19-21
• Cook Stove.....	22
• Toilet.....	22
• Pumps.....	23
• Water System Operation.....	23
• Outboard Engine and Motoring.....	24
• Electrical System.....	24
• Environmental Considerations.....	25
 <i>MAINTENANCE</i>	
• Instructions for Preparation for Bottom Painting.....	26
• Engine Maintenance.....	27
• Electrical Systems.....	27
• Plumbing Systems.....	27
• Protecting Your Rigging.....	28
• Trailer Maintenance.....	29
• General Care.....	30
• General Hardware Maintenance.....	30
• Vinyl and Fabric Care.....	31
• Electrolysis and Galvanic Protection.....	32
• Teak Care.....	33
• Storage/Winterization	34
• Lightning Warning	35

HUNTER OWNER'S MANUAL

TABLE OF CONTENTS (CONT'D)

<i>DESCRIPTION OF MODEL</i>	<i>PAGE</i>
• Profile with Rig and Sail Dimensions.....	36
• Dimensions, Capacities, etc.....	37
• Deck Plan and Hardware.....	38
• Deck Hardware and Listing.....	39
• Interior Plan.....	40
• Running Rigging Deck Plan.....	41
• Mainsheet and Jibsheet Rigging.....	42
• Proper Cleat Knot.....	43
• Boom Details and Layout.....	44
• Reef Rigging and Instructions.....	45
• Rigging Specifications.....	46
• Standing Rigging Layout and Strut Assembly.....	47
• Spreader Details.....	48
• Spinnaker Details.....	49
• Rudder Detail.....	50
<i>SYSTEMS AND CIRCUITS</i>	<i>PAGE</i>
• Potable Water System.....	51
• Bilge Pumping System.....	52
• Mast Wiring.....	53
• Electrical Schematics.....	54
• Optional Waste System.....	55
• Anchoring Arrangement.....	56

Welcome to **THE HUNTER MARINE FAMILY**

Congratulations on your new sailing yacht manufactured by Hunter Marine. We have engineered and constructed your boat to be as fine a yacht as any afloat. In order to get the best performance and most enjoyment from your boat you should be familiar with its various elements and their functions. For your sailing pleasure and safety, please take time to study this manual.

We stand behind the quality of your boat with a warranty, which you should review. To insure the validity of your warranty, please complete the attached card and send it to us within ten (10) days of the purchase date. Section 15 of the U.S. Federal Boat Safety Act requires registration of a boat's first owner. The warranty data should also be recorded in the space below for your own reference.

This manual has been compiled to help you operate your craft with safety and pleasure. It contains details of the craft;

equipment supplied or fitted, systems, and information on operation and maintenance. Please read it carefully, and familiarize yourself with the craft before using it. If this is your first sailboat or you are changing to a type of craft you are not familiar with, please ensure that you obtain proper handling and operating experience before you assume command of the craft. Your dealer or national sailing federation or yacht club will be pleased to advise you of local sea schools or competent instructors.

PLEASE KEEP THIS MANUAL IN A SAFE PLACE AND HAND IT OVER TO THE NEW OWNER IF YOU SELL THE CRAFT.

You should also complete the warranty cards for your engine, stove, head, electric water pump and other accessories. These are enclosed in the manufacturers' manuals that are packaged with your owner's manual.

OWNER INFORMATION CARD

HULL IDENTIFICATION NUMBER IS ON THE STARBOARD AFT SIDE OF THE HULL OR TRANSOM. THIS NUMBER MUST BE GIVEN IN ALL NECESSARY CORRESPONDENCE.

HULL NO.

DATE DELIVERED TO OWNER

YACHT NAME

OWNER NAME

STREET ADDRESS

CITY

STATE/COUNTRY

ZIP CODE

HOME PORT

ENGINE MODEL

SERIAL NO.

PROPELLER SIZE

DEALER

PHONE

STREET ADDRESS

CITY

STATE/COUNTRY

ZIP CODE

This Page Intentionally Left Blank



H U N T E R[®]
MARINE CORPORATION
AN EMPLOYEE OWNERSHIP COMPANY
We Go The Distance
Your Hunter Warranty

Hunter offers a limited warranty on every Hunter boat sold through an authorized Hunter dealer. A copy of this warranty is included here, and in your Operator's Manual. If for some reason you are not able to understand, read, or view this manual, please contact your local dealer for a replacement copy.

We stand behind the quality of your boat with a warranty, which you should review. To insure the validity of your warranty, please complete the attached card and send it to us within ten (10) days of the purchase date. Section 15 of the U.S. Federal Boat Safety Act requires registration of a boat's first owner. The warranty data should also be re-corded in the space below for your own reference.

The following warranties apply to all 2008 Model Year boats produced by
HUNTER MARINE CORPORATION:

===== LIMITED ONE-YEAR WARRANTY =====

Hunter Marine warrants to the first-use purchaser and any subsequent owner during the warranty period that any part manufactured by Hunter will be free of defects caused by faulty workmanship or materials for a period of twelve (12) months from the date of delivery to the first-use purchaser under normal use and service. During this period, as the sole and exclusive remedy, Hunter's obligation under the warranty is limited to the repair or replacement of any such defective part.

===== LIMITED FIVE-YEAR HULL STRUCTURE AND BOTTOM BLISTER WARRANTY =====

Hunter warrants to the first-use purchaser and any subsequent owner during the warranty period that the hull of each boat will be free from structural defects in materials and workmanship for a period of five (5) years from the date of delivery to the first-use purchaser under normal use and service.

This limited warranty applies only to the structural integrity of the hull and the supporting pan/grid or stringer system. Hulls, pan/grid or stringers modified in any way or powered with engines other than the type and size installed or specified by Hunter are not covered by this limited warranty. As the sole and exclusive remedy, Hunter's obligation under the warranty is limited to repair or replacement of any such defective part.

Hunter also warrants to the first-use purchaser and any subsequent owner during the warranty period that the boat will be free from gelcoat blistering on underwater surfaces of the hull, excluding the keel and rudder, for a period of five (5) years from the date of delivery to the first-use purchaser under normal use and service. During this period, Hunter will supply or reimburse an authorized Hunter dealer for all of the parts and labor required to repair a blistered underwater surface of the hull. The labor cost reimbursement will be based on the Labor Allowance Schedule established by Hunter from time to time, however if the repair is performed by a non-Hunter dealer, the repair cost must be authorized by Hunter in advance and be based on a reasonable number of hours as determined by Hunter. Hunter will not pay transportation, hauling, launching, bottom paint, storage, dockage, cradling rental, rigging and derigging, or other similar costs. It is recommended that the repair be done during a seasonal haul out for service or storage.

PLEASE KEEP THIS MANUAL IN A SAFE PLACE AND HAND IT OVER TO THE
NEW OWNER IF YOU SELL THE CRAFT.

You should also complete the warranty cards for your engine, stove, head, electric water pump and other accessories. These are enclosed in the manufacturers' manuals that are packaged with your owner's manual.

HUNTER EXPRESSLY DISCLAIMS THE IMPLIED WARRANTIES OF
MERCHANTABILITY AND FITNESS. NEITHER HUNTER OR THE SELLING DEALER SHALL
HAVE ANY RESPONSIBILITY FOR LOSS OF USE OF A BOAT, LOSS OF TIME,
INCONVENIENCE, COMMERCIAL LOSS, OR CONSEQUENTIAL DAMAGES.

The following circumstances will void the bottom blister limited warranty:

- (1) If the gel-coat has been sanded, sandblasted, or subjected to abrasion or impact.
- (2) If the instructions provided in the Hunter Owner's Manual are not followed according to Hunter's required bottom preparation procedures.

////////////////////// RESTRICTIONS APPLICABLE TO WARRANTIES ////////////////////////

These limited warranties do not cover:

- (1.) Paint, window glass, Gelcoat, upholstery damage, plastic finishes, engines, engine parts, bilge pumps, stoves, blowers, pressure water pumps, propellers, shafts, rudders, controls, instruments, keels and equipment not manufactured by HUNTER. Any warranty made by the manufacturer of such items will be, if possible, given on to the first use purchaser.
- (2.) Problems caused by improper maintenance, storage, cradling, blocking, normal wear and tear, misuse, neglect, accident, corrosion, electrolysis or improper operation.
- (3) Boats used for commercial activities including charter.

THESE LIMITED WARRANTIES ARE YOUR SOLE AND EXCLUSIVE REMEDIES AND ARE EXPRESSLY IN LIEU OF ANY AND ALL OTHER REMEDIES AND WARRANTIES EXPRESSED AND IMPLIED, INCLUDING THE WARRANTIES OF MERCHANTABILITY AND FITNESS FOR A PARTICULAR PURPOSE, WHETHER ARISING BY LAW, CUSTOM, CONDUCT, OR USAGE OF TRADE. SOME STATES DO NOT ALLOW LIMITATIONS ON HOW LONG AN IMPLIED WARRANTY LASTS, SO THE ABOVE LIMITATION MAY NOT APPLY TO YOU. IN THE EVENT THAT IMPLIED WARRANTIES ARE FOUND TO EXIST UNDER THE LAW OF A PARTICULAR STATE, NOTWITHSTANDING THE EXCLUSION CONTAINED HEREIN, THE DURATION OF ANY SUCH IMPLIED WARRANTY SHALL BE LIMITED TO THE DURATION OF THE APPLICABLE LIMITED WARRANTY STATED HEREIN. THE PURCHASER ACKNOWLEDGES THAT NO OTHER REPRESENTATIONS WERE MADE TO HIM OR HER WITH RESPECT TO THE QUALITY OR FUNCTION OF THE BOAT. ANY ORAL STATEMENT OR PRINTED MATERIAL ADVERTISING THE BOAT WHICH SPEAKS TO ANY PERFORMANCE CHARACTERISTIC OF THE BOAT OR ANY OF ITS COMPONENTS SHALL BE CONSIDERED AND CON-STRUED AS AN ESTIMATED DESCRIPTION ONLY AND SHOULD NOT BE RELIED UPON AS AN EXPRESS WARRANTY OR AS THE BASIS OF THE BARGAIN FOR THE BOAT OR ANY OF ITS COMPONENTS.

ANY CONSEQUENTIAL, INDIRECT OR INCIDENTAL DAMAGES WHICH MAY BE INCURRED ARE EXCLUDED AND PURCHASER'S REMEDY IS LIMITED TO REPAIRS OR REPLACEMENT OF ANY PART(S) JUDGED DEFECTIVE BY HUNTER MARINE. SOME STATES DO NOT ALLOW THE EXCLUSION OR LIMITATION OF INCIDENTAL OR CONSEQUENTIAL OR INDIRECT DAMAGES, SO THE ABOVE LIMITATION OR EXCLUSION MAY NOT APPLY TO YOU. THIS WARRANTY GIVES YOU SPECIFIC LEGAL RIGHTS, AND YOU MAY ALSO HAVE OTHER RIGHTS WHICH VARY FROM STATE TO STATE.

OWNER INFORMATION CARD

HULL IDENTIFICATION NUMBER IS ON THE STARBOARD AFT SIDE OF THE HULL OR TRANSOM. THIS NUMBER MUST BE GIVEN IN ALL NECESSARY CORRESPONDENCE.

HULL NO. _____

DATE DELIVERED TO OWNER _____

YACHT NAME _____

OWNER NAME _____

STREET ADDRESS _____

CITY _____ STATE/COUNTRY _____ ZIP CODE _____

HOME PORT _____

ENGINE MODEL _____ SERIAL NO. _____ PROPELLER SIZE _____

DEALER _____ PHONE _____

STREET ADDRESS _____

CITY _____ STATE/COUNTRY _____ ZIP CODE _____

CUSTOMER SERVICE / WARRANTY

===== WARRANTY REGISTRATION =====

These limited warranties shall not be effective unless the HUNTER Warranty Registration Form and Pre-Delivery Service Record, which are furnished with each new boat, are filled out completely and re-turned to HUNTER within ten (10) days of delivery.

Return of the Warranty Registration Form to HUNTER, signed by both Dealer and Owner, is critical. Warranty coverage cannot be initiated until the completed form is received at HUNTER.

All repairs and/or replacements will be made by an authorized Hunter dealer, or at the option of Hunter, at the Hunter plant. If the repairs are of such a nature that the warranty work must be performed at the HUNTER plant, transportation costs to and from the HUNTER plant shall be paid by the owner. The labor cost reimbursement will be based on a Labor Allowance Schedule established by HUNTER and where not applicable, on a reasonable number of hours as determined by HUNTER. Any repairs and replacements must be approved in advance by an authorized HUNTER service representative.

===== TRANSFER OF LIMITED WARRANTIES =====

For 1995 and later hull numbers, the limited warranties will be transferred to a subsequent purchaser of the boat if:

- (1) A notice of the transfer of ownership of the boat is given by the subsequent purchaser in writing to Hunter within thirty (30) days of the transfer.
- (2) The notice shall include the name, address and telephone number of the subsequent purchaser, the date of purchase, the hull number and the name of the seller of the boat.

Hunter will mail to the subsequent purchaser notice of the expiration dates of the limited warranties (see form letter, attached). The transfer of the ownership of the boat will not extend the expiration dates of the limited warranties.

===== CUSTOMER SATISFACTION SURVEYS =====

During the first year of ownership, the first purchaser will receive two Customer Satisfaction Surveys - the first (CSS#1) will be received shortly after taking delivery and focuses on the dealer's ability to sell and commission the boat, and the Owner's initial satisfaction. The second survey (CSS#2), nine to ten months into ownership, "measures" dealer service capability and allows the owner to evaluate most of the boat's functional systems and characteristics. Both surveys are dependent upon receipt of the first purchaser's Warranty Registration Form.

SAMPLE FORM LETTER

March 12, 1997

Mr. John Smith
1456 Joy Street
Sarasota, FL 34266

Dear Mr. Smith,

Thank you for providing written notice of transfer of ownership. We are pleased you have selected a Hunter sailboat and we will make every effort to assure Hunter ownership will be a satisfying experience for you.

Based on the information you have provided, we are pleased to notify you of the expiration dates of the limited warranties.

- The limited one-year New Boat warranty expires (d)_____.
- The limited five-year Hull Structure and Bottom Blister warranty expires (d)____
_____.

Should you require assistance at any time during ownership, we encourage you to contact your Hunter dealer or to call us directly at 986-462-3077.

Please confirm the information at the bottom of the page and advise us if any corrections are required.

Customer Service Manager

Hull No: HUN_____ Model:_____

Telephone: (H)_____ (B)_____

Date of Purchase:_____

Purchased From: Name:_____

Address:_____

City/State_____ Zip_____

() Private Owner () Dealer

HUNTER MARINE'S OWNER AND FOUNDER

WARREN R. LUHRS

BRIEF BACKGROUND

Warren Luhrs was born in East Orange, New Jersey in 1944 into a family with an established tradition in the maritime and transportation industries. His great-grandfather, Henry, was a railroad and clipper-shipping pioneer in America, while his great-uncle John helped build the famous St. Petersburg to Moscow railroad for Czar Alexander II.

Henry Luhrs owned shares in twenty-two different ocean-going vessels – barks, brigs, and schooners - and was the principal owner of the bark *Sophia R. Luhrs*, named for his wife. He was also a partner with Albert Sprout, who managed the shipyard where the *Sophia R. Luhrs* was built in Melbridge, Maine.

Warren Luhrs' father Henry worked at a small boat manufacturer in Morgan, New Jersey, and later started his own company, continuing the Luhrs' family sea tradition during the great depression. During World War II he repaired boats and installed ice sheathing on their bows for the Coast Guard.

After the War, Henry built 27-foot fishing boats and in 1948 began to construct custom-built pleasure craft. He then turned to skiffs and in 1952 incorporated as Henry Luhrs Sea Skiffs, where he constructed lapstrake sea skiffs using assembly-line techniques. Henry personally "shook down" his prototypes on family trips up the Hudson River to Lake Champlain.

The sea skiff is a class of boat that has been very popular, owing to its seaworthiness. It features a sharp bow, which reduces pounding in surf or

choppy seas, and a hull whose forward section is rounded below the waterline to increase stability in rough water or a following sea. Such skiffs can either be smooth sided or of a lapstrake construction.

Inspired by Henry Ford, Henry Luhrs' aimed to give the average man the opportunity to enjoy the luxury of boating by building an affordable and reliable boat. He was both designer and engineer, and his progressive new models exhibited his talent for innovation. He successfully changed the line of the bow from straight to curved at a time when the industry trend was a straight square effect, and he is believed to be the first designer-builder to popularize a small boat with a fly bridge.

In 1960, Luhrs acquired the Ulrichsen Boat Company of Marlboro, New Jersey. It was here that Luhrs' Alura fiberglass division was located. In 1965, Henry sold his company to Bangor Arrostook Railroad, which was to become the recreational conglomerate Bangor-Punta. It was also during this period that Silverton of Tom's River, New Jersey was purchased by John and Warren Luhrs.

Today, Warren R. Luhrs and his brother John own the Luhrs Group of marine manufacturers, which consists of Silverton Marine, Mainship Motor Yachts, and Luhrs Fishing Boats with its Alura division, as well as Hunter Marine, which exclusively manufactures sailboats.

In January of 1996, the Luhrs family transferred a portion of the Luhrs Group to its employees through an ESOP program.

GLOSSARY OF SAILING TERMS

A

Aback: describes a sail when the wind strikes it on the lee side.

Abaft: towards the boat's stern.

Abeam: at right angles to the *centerline* of the boat.

Aft: at or near the stern.

Amidships: the center of the boat, *athwartships* and fore and aft.

Anti-fouling: a poisonous paint compound used to protect the underwater part of a hull from marine growths.

Apparent wind: The direction and speed of the wind felt by the crew. It is a combination of *true wind* and that created by the movement of the boat.

Astern: behind the boat; to go astern is to drive the boat in reverse.

Athwartships: at right angles to the fore and aft line of the boat.

B

Back: when a wind backs, it shifts anticlockwise.

Back a sail: to sheet it to windward so that the wind fills on the side that is normally to *leeward*.

Backstay: a stay that supports the mast from aft and prevents its forward movement.

Ballast: extra weight, usually lead or iron, placed low in the boat or externally on the keel to provide stability.

Ballast keel: a mass of ballast bolted to the keel to increase stability and prevent a keel boat from capsizing.

Batten: a light, flexible strip fed into a batten pocket at the *leech* of the sail to support the *roach*.

Beam: 1, the maximum breadth of a boat; 2, a transverse member that supports the deck; 3, on the beam means that an object is at right angles to the centerline.

Bear away: to steer the boat away from the wind.

Bearing: the direction of an object from an observer, measured in degrees true or magnetic.

Beat: to sail a *zigzag course* towards the wind, *close-hauled* on alternate *tacks*.

Belay: to make fast a rope around a *cleat*, usually with a figure-of-eight knot.

Bend: 1, to secure a sail to a spar before hoisting; 2, to moor a boat; 3, a sleeping place on board.

Bight: a *bend* or loop in a rope.

Bilge: the lower, round part inside the hull where the water collects.

Block: a pulley in a wooden or plastic case, consisting of a *sheave* around which a rope runs. It is used to change the direction of pull.

Boot-topping: a narrow colored stripe painted between the bottom paint and the *topside* enamel.

Bottlescrew: see Rigging screw.

Broach: when a boat *running* downwind slews broadside to the wind and *heels* dangerously. It is caused by heavy following seas or helmsman's error.

Broad reach: the point of sailing between a beam *reach* and a *run*, when the wind blows over a quarter.

Bulkhead: a partition wall in a boat normally fitted *athwartships*

C

Caulk: to make the seams between wooden planks watertight by filling with cotton, oakum or a compound.

Cavitation: the formation of a vacuum around a propeller, causing a loss in efficiency.

Center-board: a board lowered through a slot in the *keel* to reduce *leeway*.

Center-line: center of the boat in a fore and aft line.

Center of effort (COE): the point at which all the forces acting on the sails are concentrated.

Center of lateral resistance (CLR): the underwater center of pressure about which a boat pivots when changing *course*.

Chain pawl: a short lug which drops into a toothed rack to prevent the anchor chain running back.

Chain plate: a metal plate bolted to the boat to which the *shrouds* or *backstays* are attached.

Chart datum: reference level on a chart below which the tide is unlikely to fall. Soundings are given below chart datum. The datum level varies according to country and area.

Chine: the line where the bottom of the hull meets the side at an angle.

Cleat: a wooden, metal or plastic fitting around which rope is secured.

Clevis pin: a locking pin through which a split ring is passed to prevent accidental withdraw.

Clew: the after, lower center of a sail where the foot and *leech* meet.

Close-hauled: the *point of sailing* closest to the wind; see also *beat*.

Close reach: the *point of sailing* between *close-hauled* and a beam reach, when the wind blows forward of the *beam*.

Close-winded: describes a boat able to sail very close to the wind.

Coaming: the raised structure surrounding a hatch, cockpit, etc., which prevents water entering.

Cotter pin: soft, metal pin folded back on itself to form an eye.

Course: the direction in which a vessel is steered, usually given in degrees; true, magnetic or compass.

Cringle: 1, a rope loop, found at either end of a line of reef points; 2, an eye in a sail.

D

Dead run: running with the wind blowing exactly aft, in line with the *centerline*.

Deviation: the difference between the direction indicated by the compass needle and the magnetic *meridian*; caused by object aboard.

Displacement: 1, the weight of water displaced by a boat is equal to the weight of the boat; 2, a displacement hull is one that displaces its own weight in water and is only supported by buoyancy, as opposed to a planing hull which can exceed its hull, or displacement, speed.

Downhaul: a rope fitted to pull down a sail or spar.

Draft: the vertical distance from the waterline to the lowest point of the keel.

Drag: 1, an anchor drags when it fails to hole; 2, the force of wind on the sails, or water on the hull, which impedes the boat's progress.

Drift: 1, to float with the current or wind; 2, US the speed of a current

GLOSSARY OF SAILING TERMS

(rate UK); 3, UK: the distance a boat is carried by a current in a given time.

Drogue: a sea anchor put over the stern of a boat or life raft to retard *drift*.

Drop keel: a retractable *keel* which can be drawn into the hull, when entering shallow waters and recovering on to a trailer.

E

Eye of the wind: direction from which the true wind blows.

F

Fair: well-faired line or surface is smoother with no bumps, hollows or abrupt changes in directions.

Fairlead: a fitting through which a line is run to alter the lead of the line.

Fathom: the measurement used for depths of water and lengths of rope. 1 fathom = 6 ft. or 1.83m.

Fid: a tapered tool used for *splicing* heavy rope and for sail-making, often hollow.

Fiddle: a raised border for a cabin table, chart table etc., to prevent objects falling off when the boat *heels*.

Fix: the position of the vessel as plotted from two or more position lines.

Forestay: the foremost stay, running from the masthead to the stemhead, to which the headsail is hanked.

Freeboard: vertical distance between the *waterline* and the top of the deck.

G

Genoa: a large headsail, in various sizes, which overlaps the mainsail and is hoisted in light to fresh winds on all points of *sailing*.

Gimbals: two concentric rings, pivoted at right angles, which keeps objects horizontal despite the boat's motion, e. g. compass and cooker.

Go about: to turn the boat through the *eye of the wind* to change tack.

Gooseneck: the fitting attaching the boom to the mast, allowing it to move in all directions.

Goosewing: to boom-out the headsail to windward on a run by using a *whisker pole* to hold the sail on the opposite side to the mainsail.

Ground tackle: general term used for anchoring gear.

Guard rail: a metal rail fitted around the boat to prevent the crew falling overboard.

Gudgeon: a rudder fitting. It is the eye into which the *pintle* fits.

Guy: a steadying rope for a spar; a spinnaker guy controls the fore and aft position of the spinnaker pole; the foreguy holds the spinnaker pole forward and down.

Gybe: to change from one *tack* to another by turning the stern through the wind.

H

Halyard: rope used to hoist and lower sails.

Hank: fitting used to attach the *luff* of a sail to a stay.

Hatch: an opening in the deck giving access to the interior.

Hawes pipe: see *Navel pipe*.

Head-topwind: when the bows are pointing right into the wind.

Headfoil: a streamlined surround to a *forestay*, with a groove into which a headsail *luff* slides.

Heads: the toilet.

Headway: the forward movement of a boat through the water.

Heave-to: to *back* the jib and lash the tiller to *leeward*; used in heavy weather to encourage the boat to lie quietly and to reduce *headway*.

Heaving line: a light line suitable for throwing ashore.

Heel: to lean over to one side.

I

Isobars: lines on a weather map joining places of equal atmospheric pressure.

J

Jackstay: a line running fore and aft, on both sides of the boat, to which safety harnesses are clipped.

Jury: a temporary device to replace lost or damaged gear.

K

Keel: the main backbone of the boat to which a *ballast keel* is bolted or through which the *centerboard* passes.

Kicking strap: a line used to pull the boom down, to keep it horizontal, particularly on a reach or run.

L

Lanyard: a short line attached to one object, such as a knife, with which it is secured to another.

Leech: 1, the after edge of a triangle sail; 2, both side edges of a square sail.

Leehelm: the tendency of a boat to bear away from the wind.

Lee shore: a shore on to which the wind blows.

Leeward: away from the wind; the direction to which the wind blows.

Leeway: the sideways movement of a boat off its *course* as a result of the wind blowing on one side of the sails.

Lifeline: a wire or rope rigged around the deck to prevent the crew falling overboard.

Limber holes: gaps left at the lower end of frames above the *keel* to allow water to drain to the lowest point of the *bilges*.

List: a boat's more or less permanent lean to one side, owing to the improper distribution of weight, e.g., *ballast* or water.

Log: 1, an instrument for measuring a boat's speed and distance traveled through the water; 2, to record in a book the details of a voyage, usually distances covered and weather.

Luff: the forward edge of a sail. To luff up is to turn a boat's head right into the wind.

Luff groove: a groove in a wooden or metal spar into which the *luff* of a headsail is fed.

Lurch: the sudden roll of a boat.

M

Marlin spike: a pointed steel or wooden spike used to open up the strands of rope or wire then splicing.

Mast Step: the socket in which the base of the mast is located.

Measured mile: a distance of one nautical mile measured between buoys or *transits/ranges* ashore, and marked on the chart.

GLOSSARY OF SAILING TERMS

Member: a part of the skeleton of the hull, such as a *stringer* laminated into fiberglass hull to strengthen it.

Meridian: an imaginary line encircling the Earth that passes through the poles and cuts at right angles through the Equator. All lines of longitude are meridians.

Mizzen: 1, the shorter, after-mast on a *ketch* or *yawl*; 2, the fore and aft sail set on this mast.

N

Navel pipe: a metal pipe in the fore-deck through which the anchor chain passes to the locker below.

Noon Sight: a vessel's latitude can be found, using a sextant, when a heavenly body on the observer's *meridian* is at its greatest altitude. The sight of the sun at noon is the one most frequently taken.

O

Off the wind: with the sheets slacked off, not *close-hauled*.

On the wind: *close-hauled*.

Out haul: a rope used to pull out the foot of a sail.

Overall length (OAL): the boat's extreme length, measured from the foremost part of the bow to the aftermost part of the stern, excluding bowsprit, self-steering gear etc.

P

Painter: the bow line by which a dinghy, or *tender*, is towed or made fast.

Pintle: a rudder fitting with a long pin that fits into the *gudgeon* to form a hinged pivot for the rudder.

Pitch: 1, the up and down motion of the bows of a boat plunging over the waves; 2, the angle of the propeller blades.

Point of sailing: the different angles from which a boat may sail; the boat's *course* relative to the direction of the wind.

Port: the left-hand side of the boat, looking forward (opp. of *starboard*).

Port tack: a boat is on a port tack when the wind strikes the port side first and the mainsail is out to *starboard*. A boat on the port tack gives way to a boat on a starboard tack.

Position line/ Line of position: a line drawn on a chart, as a result of taking a bearing, along which the boat's position must be, i.e. two position lines give a fix.

Pulpit: a metal *guard rail* fitted at the bows of a boat to provide safety for the crew.

Pushpit: a metal *guard rail* fitted at the stern.

Q

Quarter: the portion of the boat midway between the stern and the beam; on the quarter means about 45 degrees *abaft* the beam.

R

Rake: the fore and aft deviation from the perpendicular of a mast or other feature of a boat.

Range: 1, see *transit*; 2, of tides, the difference between the high and low water levels of a tide; 3, the distance at which a light can be seen.

Rating: a method of measuring certain dimensions of a yacht to enable it to take part in handicap races.

Reach: to sail with the wind approximately on the *beam*; all sailing points between running and *close-hauled*.

Reef: to reduce the sail area by folding or rolling surplus material on the boom or *forestay*.

Reefing pennant: strong line with which the *luff* or leech *cringle* is pulled down to the *boom* when reefing.

Rhumb line: a line cutting all *meridians* at the same angle; the *course* followed by a boat sailing in a fixed direction.

Riding light to anchor light: an all-around white light, usually hoisted on the *forestay*, to show that a boat under 50 ft. (15m.) is at anchor. It must be visible for 2 mls. (3 km.).

Rigging screw: a deck fitting with which the tensions of standing rigging, e.g. stays, shrouds, etc. are adjusted.

Roach: the curved part of the *leech* of a sail that extends beyond the direct line from head to *clew*.

Run: to run with the wind *aft* and with the *sheets* eased well out.

Running rigging: all the moving lines, such as *sheets* and *halyards*,

used in the *setting* and *trimming* of sails.

S

Scope: the length of rope or cable paid out when *mor* anchoring.

Scuppers: 1, holes in the toe rail that allow water to drain off the deck; 2, drain cockpit through hull.

Seacock: a valve that shuts off an underwater inlet or outlet passing through the hull.

Seize: to bind two ropes together, or a rope to a *spar*, with a light line.

Serve: to cover and protect a *splice* or part of a rope with twine bound tightly against the lay.

Serving mallet: tool with a grooved head, used when serving a rope to keep the twine at a constant and high tension.

Set: 1, to hoist a sail; 2, the way in which the sails fit; 3, the direction of tidal current or steam.

Shackle: a metal link with a removable bolt across the end; of various shapes: D, U.

Sheave: a grooved wheel in a *block* or *spar* for a rope to run on.

Sheet: the rope attached to the *clew* of a sail or to the boom, enabling it to be controlled or *trimmed*.

Shrouds: ropes or wires, usually in pairs, led from the mast to the *chain plates* at deck level to prevent the mast falling sideways; part of the standing rigging.

Sloop: a single-masted sailing boat with a mainsail and one head sail.

Spar: a general term for any wooden or metal pole, e.g., mast or boom, used to carry or give shape to sails.

Spindrift: spray blown along the surface of the sea.

Spinnaker: a large, light, balloon shaped sail set when *reaching* or *running*.

Splice: to join ropes or wire by unlaying the strands and interweaving them.

Split pin: see *cotter pin*.

Spreaders: horizontal struts attached to the mast, which extends to the *shrouds* and help to support the mast.

GLOSSARY OF SAILING TERMS

Stall: a sail stalls when the airflow over it breaks up, causing the boat to lose way.

Stanchion: upright metal post bolted to the deck to support guardrails or lifelines.

Standing part: the part of a line not used when making a knot; the part of a rope that is made fast, or around which the knot is tied.

Standing rigging: the shrouds and stays that are permanently set up and support the mast.

Starboard: right-hand side of a boat looking forward (opp. of *port*).

Starboard tack: a boat is the starboard tack when the wind strikes the starboard side first and the boom is out to the *port*.

Stay: wire or rope which supports the mast in a fore and aft direction; part of the *standing rigging*.

Steerage way: a boat has steerage way when it has sufficient speed to allow it to be steered, or to answer the helm.

Stem: the timber at the bow, from the keel upward, to which the planking is attached.

Sternway: the backward, stern-first movement of a boat.

Stringer: a fore and aft member, fitted to strengthen the frames.

T

Tack: 1, the lower forward corner of a sail; 2, to turn the boat through the wind so that it blows on the opposite sides of the sails.

Tacking: working to windward by sailing *close-hauled* on alternate *courses* so that the wind is first on one side of the boat, then on the other.

Tack pennant: a length of wire with an eye in each end, used to raise the tack of a headsail some distance off the deck.

Tackle: a purchase system comprising of rope and *blocks* that is used to gain mechanical advantage.

Tang: a strong metal fitting by which *standing rigging* is attached to the mast or other *spar*.

Tender of dinghy: a small boat used to ferry stores and people to a yacht.

Terminal fitting: fitting at the end of a wire rope by which a *shroud* or stay can be attached to the mast, a *tang* or a *rigging screw/turnbuckle*.

Tide: the vertical rise and fall of the oceans caused by the gravitational attraction of the moon.

Toe rail: a low strip of metal or molding running around the edge of the deck.

Topping lift: a line from the masthead to a spar, normally the boom, which is used to raise it.

Topsides: the part of a boat's hull that is above the waterline.

Track: 1, the course a boat has made good; 2, a fitting on the mast or boom into which the slides on a sail fit; 3, a fitting along which a traveller runs, used to alter the angle of the sheets.

Transit: two fixed objects are in transit when seen in line; two transit give position fix.

Traveller: 1, a ring or hoop that can be hauled along a *spar*; 2, a fitting that slides in a *track* and is used to alter the angle of the *sheets*.

Trim: 1, to adjust the angle of the sails, by means of *sheets*, so that they work most efficiently; 2, to adjust the boat's load, and thus the fore and aft angle at which it floats.

True wind: the direction and speed of the wind felt when stationary, at anchor or on land.

Turnbuckle: see *Rigging screw*.

U

Under way: a boat is under way when it is not made fast to shore, at anchor or aground.

Uphaul: a line used to raise something vertically, e.g., the spinnaker pole.

V

Veer: 1, the wind veers when it shifts in clockwise direction; 2, to pay out anchor cable or rope in a gradual, controlled way.

W

Wake: the disturbed water left *astern* of a boat.

Waterline: the line along the hull at which a boat floats.

Waterline length (WL): the length of a boat from *stem* to *stern* at the *waterline*. It governs the maximum speed of *displacement hull* and effects a boat's *rating*.

Weather helm: (opp. of *lee helm*).

Weather side: the side of a boat on which the wind is blowing.

Wetted surface: the area of the hull under water.

Whisker pole: a light pole used to hold out the *clew* of a headsail when *running*.

Winch: a mechanical device, consisting usually of a metal drum turned by a handle, around which a line is wound to give the crew more purchasing power when hauling taut a line, e.g. a jib *sheet*.

Windage: those parts of a boat that increase *drag*, e.g., rigging, spars, crew, etc.

Windlass: a *winch* with a horizontal shaft and a vertical handle, used to haul up the anchor chain.

Windward: the direction from which the wind blows; towards the wind (opp. of *leeward*).

Y

Yawl: a two masted boat with a mizzen stepped aft of the rudder stock/post.

EXPLANATION OF SAFETY PRECAUTIONS

This manual contains safety precautions that must be observed when operating or servicing your boat.

Review and understand these instructions.

DANGER

Denotes an extreme intrinsic hazard exists which would result in high probability of death or irreparable injury if proper precautions are not taken

WARNING

Denotes a hazard exists which can result in injury or death if proper precautions are not taken

CAUTION

Denotes a reminder of safety practices or directs attention to unsafe practices which could result in personal injury or damage to the craft or components

SAFE BOATING TIPS

BE PREPARED

Take a safe boating course. In the U.S., contact your local Boating Industry for details.

Carry all safety equipment required by the laws that apply to your area. Requirements are generally available from the Coast Guard or your local boating industry.



WARNING

As the owner of the craft, obtaining and maintaining necessary safety equipment is your responsibility. For more information about equipment required, contact local boating authorities

MINIMUM RECOMMENDED SAFETY EQUIPMENT

- Required life saving equipment, including life vests and throwables.
- First Aid kit
- Anchor with sufficient line and/or chain
- Flashlight with good batteries
- Binoculars
- Appropriate navigational charts
- Flares
- Noise emitting device
- Sufficient food and water provisions
- Sunglasses and block
- Blanket
- Oar(s)

The legally required on-board safety equipment may vary by region or body of water. Please check with local authorities prior to departure for a safety examination.

LIFE JACKETS

A life jacket may save your life, but only if you wear it. Keep jackets in a readily accessible place – not in a closed compartment or stored under other gear. Remove them from any packaging, and keep throwable floatation devices ready for immediate use.



WARNING

It is very important that children, handicapped people, and non-swimmers wear lifejackets at all times. Make sure all passengers are properly instructed in use of life saving gear

FIRE EXTINGUISHERS

Approved fire extinguishers are required on most boats, local authorities can provide details. All passengers should know the location and operating procedure of each fire extin-

guisher. Fire extinguishers are normally classified according to fire type. Be familiar with the type of fire extinguishers you have on board.

SAFE BOATING TIPS

FLARES

Most boats operating on coastal waters are required to carry approved visual distress signals, therefore check with your local authorities as to which types are required.

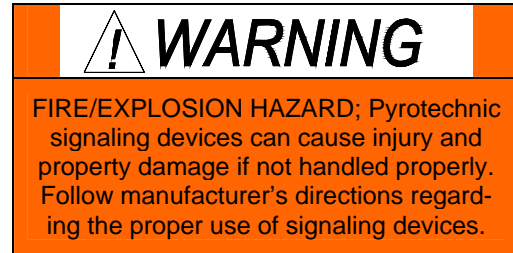

DRUGS AND BOATING

Consumption of alcohol while boating is not recommended. The combination of noise, sun, wind, and motion act to produce fatigue on the water, and can exaggerate the effects of alcohol.

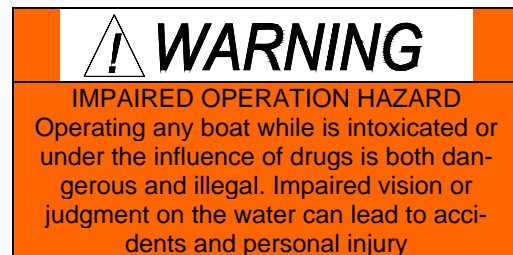

BEFORE GETTING UNDERWAY

- Leave a float plan (example included).
- Perform a pre-departure checklist (example included).
- Check the weather. Do not venture out if the weather is, or will be, threatening.

WHILE UNDERWAY

- Keep a good lookout. Keep a watch to the leeward under the headsail. Keep away from swimmers, divers, and skiers.
- Know and obey local boating laws.
- Respect bad weather, and be prepared for quickly changing conditions.

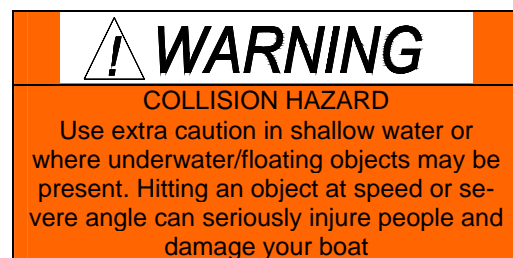

Dear Hunter Owner,

Attached you will find a list of items and recommendations that we believe should be incorporated into your own ongoing list of preventative maintenance items and safety check points. THIS LIST SHOULD NOT BE CONSIDERED A COMPLETE SERVICE MANUAL OR THE ONLY ITEMS ON YOUR BOAT IN NEED OF ROUTINE MAINTENANCE, INSPECTION OR ATTENTION.

You will find that we address commonly found optional equipment items installed on Hunter boats, as well as most standard equipment from Hunter Marine. Owner's need to familiarize themselves with individual equipment manuals on all such items, especially aftermarket purchases or optional equipment installed by your dealer or Hunter Marine. This should insure that you are following the manufacturer's recommendations for proper maintenance and up-keep.

We strongly recommend that all owners complete a Power Squadron course followed with a complementary boat inspection before leaving the dock. To locate a Power Squadron in your area please visit < www.usps.org >.

Reviewing and familiarizing yourself with the Chapman's Piloting Manual is also highly recommended for every boat owner. This manual contains demonstrations for safety drills which should be practiced routinely, dealing with adverse conditions, general boat handling and recommended safety equipment. Our opinion is that no boat owner should operate a boat without first reviewing this manual and without having ready access to it while sailing.

We hope that this list will be beneficial to you in your ongoing maintenance and upkeep. Safe boating!

Thank You

Hunter Marine

Preliminary care and maintenance checklist

A qualified Technician should be used if you are not completely confident in your ability to make repairs or inspections.

Out of Water Inspection

Pre-launch inspection

- ___ Sacrificial zinc anodes installed
- ___ Propeller installed with keyway, nuts and cotter pin
- ___ Propeller shaft turns freely and without excess wobble
- ___ Struts and shaft log free of corrosion
- ___ Rudder swings easily & correct with wheel direction
- ___ Rudder and post inspected for cracks and/or concealed damage (may require removing rudder)
- ___ Auxiliary tiller handle properly aligned, fits securely and operational
- ___ Backup rudder system complete and operational
- ___ All thru-hulls and valves below water line inspected for corrosion, labeled and closed until after launch
- ___ Bottom paint in satisfactory condition
- ___ Hull freshly cleaned and waxed (free of gelcoat damage)
- ___ Mooring, safety lines and fenders onboard and in good condition
- ___ House & engine start batteries installed and filled with correct electrolyte levels
- ___ House & engine start battery boxes secured
- ___ All battery terminals clean and wires secured
- ___ Engine block & transmission drains closed
- ___ Speed / Depth transducers in place. Speed paddle wheel rotates smoothly
- ___ Hose clamps on all systems below water line tight
- ___ Keel bolts tight and clean
- ___ Exhaust hose attached and secured
- ___ Boat is free of internal and external water leaks above water line (Failure to stop water intrusion could result in permanent damage or deterioration of structural coring materials, internal wiring and cause mildew and molding)

Mast Assembly

- ___ Review manufacturers manual for maintenance and up-keep
- ___ Spreaders securely fastened
- ___ Mast and spreaders free of corrosion and stress cracks
- ___ Standing rigging and pins inspected for wear, tear, corrosion and cracking
- ___ External wiring secured for anchor, steaming and deck lights
- ___ Electronic wind indicator installed per manufacturers recommendation
- ___ Manual wind indicator installed on masthead
- ___ VHF antenna installed and connected
- ___ Headsail furling system installed inspected per manufacturers recommendation
- ___ Running rigging inspected for wear and tear
- ___ Mast step stand-up blocks secured and operational
- ___ Main Sail, jib sail and flaking system inspected for wear and tear (non-furling mast). In-mast system checked for smooth operation and overall condition of sails
- ___ Specified pre-bend and diagonal tensions attained in mast. See owners manual
- ___ Mast to deck wiring properly sealed with drip loop

Anchor System and Ground Tackle

- ___ Anchor windlass inspected per manufacturers recommendation
- ___ Anchor secured in bow roller assembly
- ___ Spare anchor onboard and accessible. See Chapman's Manual for recommendations on anchors, anchor lines and drogues
- ___ Anchor line pays out and retrieves into anchor locker without difficulty
- ___ Bitter end of anchor line secured
- ___ Anchor rode inspected and free of abrasions
- ___ Anchor chain shackle lock-wired at pin after secured to anchor and corrosion free
- ___ Anchor locker hatch secures properly with anchor and line in place
- ___ Anchor locker free of debris inside
- ___ Anchor locker drains open

Fuel System

- ___ Tank fuel level indicator functioning properly
- ___ Fuel clean and treated with engine manufacturers recommended additives
- ___ Primary and secondary filters cleaned or replaced
- ___ Fuel tank supply valves open
- ___ Fuel tank vent clear from tank to atmosphere (hose has anti-siphoned loop in place at hull or deck side)

Steering System

- ___ Inspect and service steering system according to manufacturer's recommendation
- ___ Clean and grease autopilot drive chains
- ___ Ensure compass light is operational

Primary Pumps Functional

- ___ Manual bilge pumps
- ___ Electric bilge pumps and float switches (discharge hose has anti-siphon loop in place to prevent back flow under sail)
- ___ Macerator pumps
- ___ Fresh water pumps
- ___ Toilet flush pumps
- ___ Shower sump pumps
- ___ High water bilge alarm pump

Illumination and small electrical components check

- ___ Bow light
- ___ Cabin lights
- ___ Stern light
- ___ Deck light
- ___ Instrument lamps
- ___ Masthead light
- ___ Chart light
- ___ Anchor light
- ___ Courtesy lights
- ___ Reading lights
- ___ Distribution panel lights
- ___ Smoke detectors operational
- ___ CO detectors operational (one per cabin recommended)
- ___ Engine & generator room blower operational
- ___ Auto fire suppression system operational (engine compartment)
- ___ Shore power cord and adapter plug operational. See manufacturer's manual for complete details
- ___ 110 or 220 VAC outlets operational – Ground fault circuits functioning
- ___ 110 or 220 VAC inverter/battery charging systems functioning properly
- ___ Cockpit control systems operational

Fresh Water Systems

- ___ Hot water heater drains shut
- ___ All spigots and hose bibs shut
- ___ All tanks flushed clean and free of debris and antifreeze
- ___ Water heater tank and lines flushed of antifreeze
- ___ All water lines and components purged of air and checked for leaks
- ___ Sinks and drains checked for leaks and adequate flow
- ___ Cockpit shower operational
- ___ Fresh water filters clean
- ___ Tank water level indicator systems operating – labeling and tank valve selection correspond

Head and Holding Tank Systems

- ___ Vent clear from tank to atmosphere
- ___ Filled with fresh water and test pumped with macerator
- ___ Toilets flush to holding tanks properly
- ___ Waste level indicating system properly functioning
- ___ No leaks at any hose fitting within the system

Galley Systems

- ___ Gas bottle filled installed and connected to regulator. Inspect Gas system for leaks after 3 minutes. Should a leak be detected, immediately close the main valve, exit boat and seek professional assistance for a thorough inspection.
- ___ Stove and oven operational. Refer to manufacturer's manual for proper operation and trouble shooting.
- ___ Gimbal latch secure and operational
- ___ LPG stowage locker drain open and tank storage area free of debris.
- ___ Microwave operational
- ___ Refrigerator operational and proper temperature attained
- ___ Freezer operational and proper temperature attained
- ___ USCG waste disposal-warning poster onboard or in owner's package
- ___ Icebox drains to sump or bilge properly
- ___ Icebox drain plugs installed

Topside Inspection

- ___ Swim seats / ladders / gates operational
- ___ Swim seat latch operating correctly
- ___ Cockpit hatches operate properly (adjustments should be made with boat in water)
- ___ Canvas properly cleaned and installed
- ___ Cockpit cushions cleaned and installed
- ___ Lifeline fittings tight and secure
- ___ Rubrail sealed secured to hull
- ___ Sliding hatches drains free of debris
- ___ Companionway drop-ins fit properly in companionway and stowage rack
- ___ Load bearing hardware sealed and securely fastened. This includes but is not limited to chainplates, winches and handrails
- ___ Traveler arch sealed and securely fastened. Stainless Steel models should be properly grounded, see owners manual for details
- ___ Plexiglas hatches, ports, windscreens and windows adjusted and cleaned. Cleaners and polishers specifically for Plexiglas can be purchased from most marine supply stores
- ___ External teak cleaned and oiled (Teak decking cleaned with mild soap and water)
- ___ External railings cleaned with soap and water then hand polished using automotive wax
- ___ All deck fill caps seal properly and have retainer chains intact (except Waste Pump-out)
- ___ Dorade vents or sealing caps installed
- ___ Topside surface clean and free of gelcoat damage

Interior Inspection

- ___ Drop-in hatches for bunks and floors in place and fit securely
- ___ Interior steps and grab rails secured
- ___ Bilges clean and free of debris
- ___ Opening port and hatch screens in place
- ___ Blinds / privacy curtains, shades and interior cushions cleaned, installed and secured
- ___ All doors open / shut / latch properly
- ___ Insure all wires and connection on distribution panels are tight (should be professionally inspected)
- ___ Television / VCR operational
- ___ Stereo / Tape / CD operational
- ___ Chapman's Manual onboard and readily available
- ___ Safety gear onboard readily available and up to date. See Chapman's Manual and US Coast Guard website at < www.uscg.mil >for details.
- ___ Boat owner's manual onboard

In Water Inspection

Dockside inspection of Engine, Pre-start sequence and operating system

- ___ Review engine manual for maintenance requirements and proper starting procedure
- ___ Propeller shaft properly aligned (per engine manual)
- ___ Shaft to engine coupling bolted and properly torque (per engine manual)
- ___ All engine mounting bolts in place and properly torque (per engine manual)
- ___ Crankcase oil at full mark (per engine manual)
- ___ Transmission fluid / oil at full mark (per engine manual)
- ___ Coolant mix ratio proper – heat exchanger and expansion tanks full (per engine manual)
- ___ Seawater intake valve open and no leaks
- ___ Air bled from fuel lines and system
- ___ No fuel leaks at any fittings
- ___ Throttle linkages smooth and operational
- ___ Shutdown system operational
- ___ USCG Oil Discharge warning poster in place
- ___ Exhaust elbows and hoses tight
- ___ Starting sequence and alarms correct
- ___ Oil pressure acceptable (per engine manual)
- ___ Coolant temperature acceptable (per engine manual)
- ___ Alternator DC output at rated rpm (per engine manual)
- ___ Correct Idle rpm (per engine manual)
- ___ Water discharged with exhaust
- ___ Hour meter operational
- ___ Fuel level indicators operational
- ___ Throttle cable tension set properly
- ___ Shifter operation correct
- ___ Neutral safety start switch operational
- ___ No inboard exhaust gas leaks
- ___ No fuel / oil / water leaks on engine
- ___ Shaft packing / Drip free Seal adjusted and locknuts tight. One to three drips per minute with shaft turning on traditional packing assembly
- ___ Engine box installed and secured

Dockside inspection of Generator, Pre-start sequence and operating system

- ___ Review and follow manufacturer's manual for maintenance and up-keep
- ___ Seawater strainer water-tight and clean
- ___ No leaks in fuel system - Fuel filters clean
- ___ Lube oil at full mark
- ___ Coolant level full – proper mix ratio with water (per generator manual)
- ___ Seawater discharge overboard with exhaust gas
- ___ No inboard water or exhaust gas leaks
- ___ Proper voltage output to distribution panel (per generator manual)
- ___ Ship / Shore power transfer panel function properly
- ___ Starter battery box secured
- ___ Starter battery cable connections clean and tight
- ___ Starting battery electrolyte level proper

Climate Control System

- ___ Review and follow manufacturers manual for maintenance and up-keep
- ___ Seawater strainer water tight and clean
- ___ Seawater pump air purged and operational
- ___ Seawater flow adequate fwd and aft
- ___ Fwd system functions properly in all modes of operation
- ___ Aft system functions properly in all modes of operation
- ___ No seawater leaks in system components and lines
- ___ No condensation leaks to deck or liner
- ___ Air return/intake filters clean and clear
- ___ 110 or 220 VAC 30 amp shore power wired correctly at dock
- ___ Remote control units and display features operate correctly
- ___ Condensation drains open

Dockside Pre-sail inspection

- ___ Standing rigging tuned statically – all fittings pinned and secured (re-check after sailing)
- ___ Genoa installed and furling system operational
- ___ Main sail installed and operates smoothly
- ___ Main sail flaking system properly adjusted
- ___ All reefing points attained properly
- ___ Topping lift and outhaul operational
- ___ Sheets / Blocks / Winches operate correctly and easily under load
- ___ Genoa Car travels freely full length on tracks port and starboard
- ___ All line stoppers operational and labeled
- ___ Calibrate all electronic equipment and compass to geographical area.
- ___ VHF operational
- ___ Battery negative to keel ground voltage check. Mast and arch must be installed for this check. This will verify no wires have shorted out to your keel/lighting ground system. digital multimeter required.
- ___ Dockside water connection operable and free of leaks
- ___ Complete safety package onboard and up-to date (see Chapman's manual and US Coast Guard rules and regulations)
- ___ Secure and evenly distribute all loose equipment and weight
- ___ Complementary onboard inspection made by local Power Squadron

Date of inspection: _____

Inspection made by _____

Dates of practice drills and onboard safety inspections

MY PERSONAL PREFERENCES FOR MAINTENANCE ITEMS & SAFETY GEAR

PRE-DEPARTURE CHECKLIST

- Check bilge for extra water
- Check weather conditions and tides
- Check food supply
- Foul weather gear
- Linen, sleeping bags
- Fuel
- Water
- Sunscreens and sunglasses
- Tools
- Docking and anchor gear
- Check radio operations
- Navigation charts and instruments
- Float plans to a friend or Coast Guard** (*see next page*)
- Fuel for stove
- Cooking and eating utensils
- Check battery water level
- Oil level, tight Vp-belts
- Check for loose electrical connections in engine compartment
- Secure tools or any loose equipment in engine compartment so as not to get fouled in engine
- AC systems off; electrical cord stowed
- Doors and drawers secured
- Check steering lock to lock
- Check mast for rigging irregularities and tightness
- Halyards and sheets are clear and ready to run
- No lines or other obstructions near propeller or bow
- Anchor ready to run
- Check lifelines for tightness
- Turn on fuel and waterlines
- Stow all loose gear
- Open engine cooling water intake thru-hull valve

CE CERTIFIED

Your Hunter has been manufactured in the United States and has been certified by the IMCI to be in compliance with the relevant parts of the Recreational Craft Directive 94/25/EC from the European Parliament. The CE mark means your craft meets or exceeds the applicable current International Organization for Standardization (ISO) standards and directives as stated on the CE certificate supplied with your craft. The builder's plate, affixed to your boat, describes various parameters involved in the design of your boat. Please refer to it regularly when operating your boat.

Following are the Design Categories, established by the Recreation Craft Directive, which is to be considered a guideline of use application as per the Directive's criteria. Hunter Marine Corporation does NOT establish these criteria, and the category indicated is only a reference to the assigned category. The safety of the captain and crew of any vessel is not measurable by such categories, and you should not interpret these categories as an indication of your safety in such condition. The skill of your captain and crew, together with proper preparation, appropriate safety equipment for the given conditions and a well maintained vessel are critical to safe sailing.

CE CRAFT DESIGN CATEGORIES

Category A – "Ocean": Craft designed for extended voyages where conditions may exceed wind force 8 (Beaufort Scale) and include significant wave heights of 4m, for vessels that are largely self-sufficient.

Category B - "Offshore": Craft designed for offshore voyages where conditions include winds up to and including wind force 8 and significant wave heights up to and including 4m may be experienced.

Category C – "Inshore": Craft designed for voyages in coastal waters, large bays, estuaries, lakes and rivers, where conditions up to and including wind force 6 and significant wave heights up to and including 4m may be experienced.

Category D – "Sheltered Waves": Craft designed for voyages on small lakes, rivers and canals, where conditions up to and including wind force 4 and significant wave heights up to and including 0.5m may be experienced.

For additional information, contact

International Marine Certification Institute (IMCI)
Treves Centre, rue de Treves 45
1040 Brussels, Belgium
FX: (32) 2238-7700

NMMA CERTIFIED

Your Hunter has been judged by the National Marine Manufacturers Association (NMMA) to be in compliance with the applicable federal regulations and American Boat and Yacht Council (ABYC) standard and recommended practices in effect at the time of manufacture.

For additional information, contact:

National Marine Manufacturers Association
200 E. Randolph Dr., Suite 5100
Chicago, IL 60611
PH: (1) 312-946-6200 FX: (1) 312-946-0388

FLOAT PLAN

1. Name of person reporting and telephone number:

2. Description of boat

NAME	TYPE	
MAKE	LENGTH	REGISTRATION#
HULL COLOR	STRIPE COLOR	DECK COLOR
OTHER DISTINGUISHING MARKS		

3. Number of Persons aboard

NAME	AGE	PHONE #
ADDRESS		
NAME	AGE	PHONE #
ADDRESS		
NAME	AGE	PHONE #
ADDRESS		

4. Engine

TYPE	H.P.	FUEL CAPACITY
------	------	---------------

5. Safety equipment

PFDs	<input type="checkbox"/>	Flares	<input type="checkbox"/>	Mirror	<input type="checkbox"/>	Flashlight	<input type="checkbox"/>
Food	<input type="checkbox"/>	Water	<input type="checkbox"/>	EPIRB	<input type="checkbox"/>	Raft/Dinghy	<input type="checkbox"/>

6. Radio

TYPE	FREQUENCIES
------	-------------

7. Trip Expectations

DEPARTURE TIME	DATE	FROM
DESTINATION	RETURN DATE	NO LATER THAN

8. Automobile:

LICENSE #	STATE	MAKE
COLOR	PARKED AT	

9. If not returned by-

Contact the Coast Guard or-

CALL -	AT-
--------	-----

AFTER SAILING CHECK LIST

When leaving your Hunter at the dock for more than a short time, it is a good idea to review the following checklist to make sure everything is in order. This

will help protect the various parts of your boat and add to their attractiveness and usable life.

- ❑ Flake or furl mainsail and cover, or remove and bag.
- ❑ Remove and stow all portable deck hardware such as snatch blocks, winch handles, etc.
- ❑ Secure the boom to the topping lift and set it firmly amidships with the main-sheet purchase. (It is a good idea to rig a line from the steering wheel or tiller to a convenient cleat to keep the rudder from swinging back and forth with the motion of the water or employ the wheel brake if so equipped.
- ❑ Attach the shackle ends of all halyards to convenient fittings and take up slack. Find a location leading away from the mast to keep the halyard from slapping the mast.
- ❑ Coil and stow all lines in line lockers.
- ❑ Cover the winches and steering pedestal when leaving the boat for several days or more.
- ❑ Close all fuel lines and seacocks.
- ❑ Switch off the electrical system.
- ❑ Pump out the bilge.
- ❑ Check air vents, secure ports and hatches, swab the deck, and clean deck stainless, particularly if you have operated in saltwater.
- ❑ Make a final check of mooring lines, chafing gear, fenders, etc.

SAFE BOATING TIPS

DOCKING

Docking your boat should be handled carefully to avoid potential damage. Under normal wind and water conditions, the following considerations should be made:

1. Whenever possible, your approach should be made against the prevailing wind and current to assist in stopping the boat. Where these conditions are contrary, the strongest should be used to determine approach.
2. Approaching the dock: dock lines should be at ready, loose gear stowed and decks cleared. Determine the direction of the wind and current and when you decide which side of the boat will be against the dock, rig dock lines and

fenders on the appropriate side. One dock line should be attached to the bow cleat, another to the stern cleat opposite the side that will lie against the dock.

NOTE: If the boat is to lie against a piling, rig a fender board across two or more pilings.

3. Tying up: attach bow and stern lines to dock, hauling boat in with fenders against dock. Rig crossing spring lines to limit motion forward and aft. Be sure to allow some slack in all lines to compensate for tidal activity if present. Never use bow rail, stern rail, or stanchions to secure a vessel, even for brief periods. For other types of moorings, or for abnormal wind or water conditions, consult an approved boating guide.

ANCHORING

Your Hunter comes with an on-deck anchor well and a Danforth type anchor as standard equipment. The anchor is selected to suit the size and weight of your boat under normal anchoring conditions, and provides its best holding characteristic in muddy or sandy bottoms.

When anchoring, pay particular attention to the slope of your anchor rode (i.e., the relationship between the depth of the water and the length of the rode). A good rule of thumb is to allow a scope of about 7:1 (a rode seven times as long as the vertical distance from the bow to the bottom). A helpful aid is to mark the rode every 20 feet or so with knots or other types of indicators. Before dropping anchor, make sure the bitter end is secured to the cleat in the anchor well.

Also, be sure to consider wind direction, currents, mean low tide depths and other local conditions when anchoring, as well as the positions of any boats already anchored nearby.

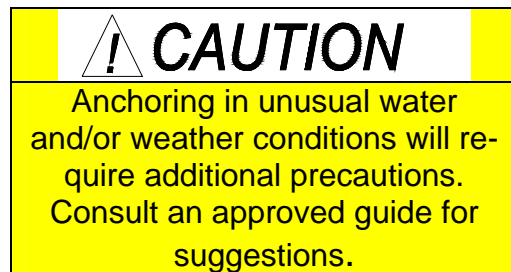

To weigh anchor, motor or sail (under main only) forward slowly. When at a point directly above the anchor, a quick tug should free it from the bottom. Take care not to damage the topsides when hauling.

MAST RAISING & LOWERING SYSTEM

WARNING: MAKE SURE THAT THE MAST AND RIGGING IS CLEAR OF ALL OVERHEAD ELECTRICAL CABLES WHEN BEING RAISED OR LOWERED OR MANEUVERED ABOUT THE LAUNCH AREA. CONTACT WITH AN ELECTRICAL CABLE CAN CAUSE SEVERE INJURY OR DEATH.

1. Confirm that all standing rigging and spreaders are connected to the spar as per the drawings in this owner's manual. The spreader retaining pins should be installed and pinned, the spreader tip tightened in the correct location and all black rubber retainer plugs installed in the rigging terminals on the mast. These plugs prevent the shrouds from falling out of the mast when the mast is lowered. All halyards should be installed and the mast light installed.
2. Confirm that the white "boots" are installed over each shroud turnbuckle and that the turnbuckles are attached to the chain plate "U" bolts with the cotter pins located inboard. The boots must be forced down over the turnbuckle toggles to prevent the turnbuckles binding on the "U" bolts and bending during the stepping process.
3. Untie the mast from the bow pulpit and support crutch, and slide the mast aft on the support crutch roller until the base of the mast is over the mast step. At this point the mast will be balanced on the roller only, so do not let go of the mast base. The mast struts remain attached during this procedure.
4. Remove the stainless steel mast step pin from the mast step casting, being careful not to lose the boom vang strap.
5. Push the mast base down until the retaining pin holes in the base align with the corresponding holes in the step, and reinstall the stainless steel retaining pin, being careful to reinstall the boom vang strap at this time. Install the split ring to the retaining pin.
6. Open the anchor locker and attach the lower end of the mainsheet tackle (the end with the jam cleat) to the "U" bolt inside the locker.
7. Connect the mast raising tube to the pin in front of the spar.
8. Holding the pole in a vertical position, connect the jib halyard shackle to the aft loop at the top end of the pole. Tension the halyard by pulling it from the exit at the line stopper (make sure that the jib halyard is being tensioned, and not the main halyard) until the mast raising pole is angled aft approximately 10 degrees. Lock down the line stopper and securely cleat the halyard to the black plastic cleat on the side of the deck outboard of the line stopper.
9. While still holding the mast raising pole at the ten degree aft angle, connect the upper end of the mainsheet tackle to the forward loop at the end of the mast raising pole and take out the slack through the jam on the lower block of the mainsheet.
10. Check to make sure that the forestay is not twisted around the jib halyard, that the upper and lower shrouds are not twisted around each other and are outside the life lines, that the turnbuckles are vertical on the "U" bolts, the spar is clear of all overhead electrical wiring, all shrouds, mast raising bridles and forestays are properly attached to the spar, all shackles on the mainsheet and jib halyards are properly closed, the jib cleat is properly cleated to the spar, no one is standing in the cockpit or under the mast and, in all respects, the mast is ready to raise.
11. Pull on the mainsheet tackle to raise the spar making sure that the mainsheet always runs through, and is being held by the jam cleat. With the mast struts installed, the mast is prevented from moving side to side, so you can rest between pulls and it is not necessary to have anyone pushing the spar up from behind as you are pulling on the tackle, although this will reduce the load on the tackle and speed up the process. The load on the tackle will be at a maximum at the beginning of the raising process and will reduce progressively as the spar is raised, reducing to almost nothing when the spar is up. With the anchor locker open, the bow of the boat has limited space in which to work, so be careful and watch your footing. There is no need to hurry.

MAST RAISING & LOWERING SYSTEM

12. When raised, leave the mainsheet jammed and tensioned. Take the forestay forward and connect to the forward of the two holes in the stemhead fitting.

13. Connect mast wiring plug to deck fitting at starboard base of spar.

14. Refer to GETTING READY TO SAIL.

MAST LOWERING

1. Remove sails, boom vang and boom.

2. Install mast support crutch to transom, if not already done.

3. Install mast raising pole.

4. Attach jib halyard shackle to upper spliced eye at forward end of mast raising pole.

5. Tension jib halyard (again confirming that it is the jib halyard being tensioned and not the main halyard—check the color coding) so that the pole angles up at the front end approximately 10 degrees. Secure halyard to cleat on side of deck, and lock down the line stopper.

6. Attach bottom end of mainsheet to “U” bolt in anchor locker and top end to bottom loop at end of mast raising pole. Tension mainsheet tackle so jib halyard takes the load. Make sure mainsheet is jammed and for extra security secure to bow mooring cleat.

7. Loosen forestay turnbuckle and remove forestay from stemhead fitting.

8. Check for overhead electrical cables, make sure that no one is standing in the cockpit or under the spar, and confirm that the spar is in all respects ready to lower.

9. Allowing the mainsheet to hook around the bow mooring cleat, unjam the mainsheet and, holding the mainsheet tail in one hand, ease tension on the mainsheet tackle while pushing the spar aft with your other hand. Retaining the deflection of the mainsheet around the cleat, ease the mainsheet further until the spar begins to hinge aft.

10. Continue lowering the spar, remembering that the load on the tackle will increase as the spar is being lowered, until the spar rests in the mast crutch.

11. Disconnect the mast raising pole, mast electrical wiring and uncleat halyards aft so the spar can slide forward.

12. Remove mast step pin and disconnect mast base from step while restraining bottom end of mast and retaining boom vang strap. Replace pin, vang strap and cotter pin.

13. Slide mast forward on mast crutch roller until base of mast rest in bow pulpit. Secure mast in place at pulpit and at mast crutch. Take slack out of shrouds and secure forestay forward.

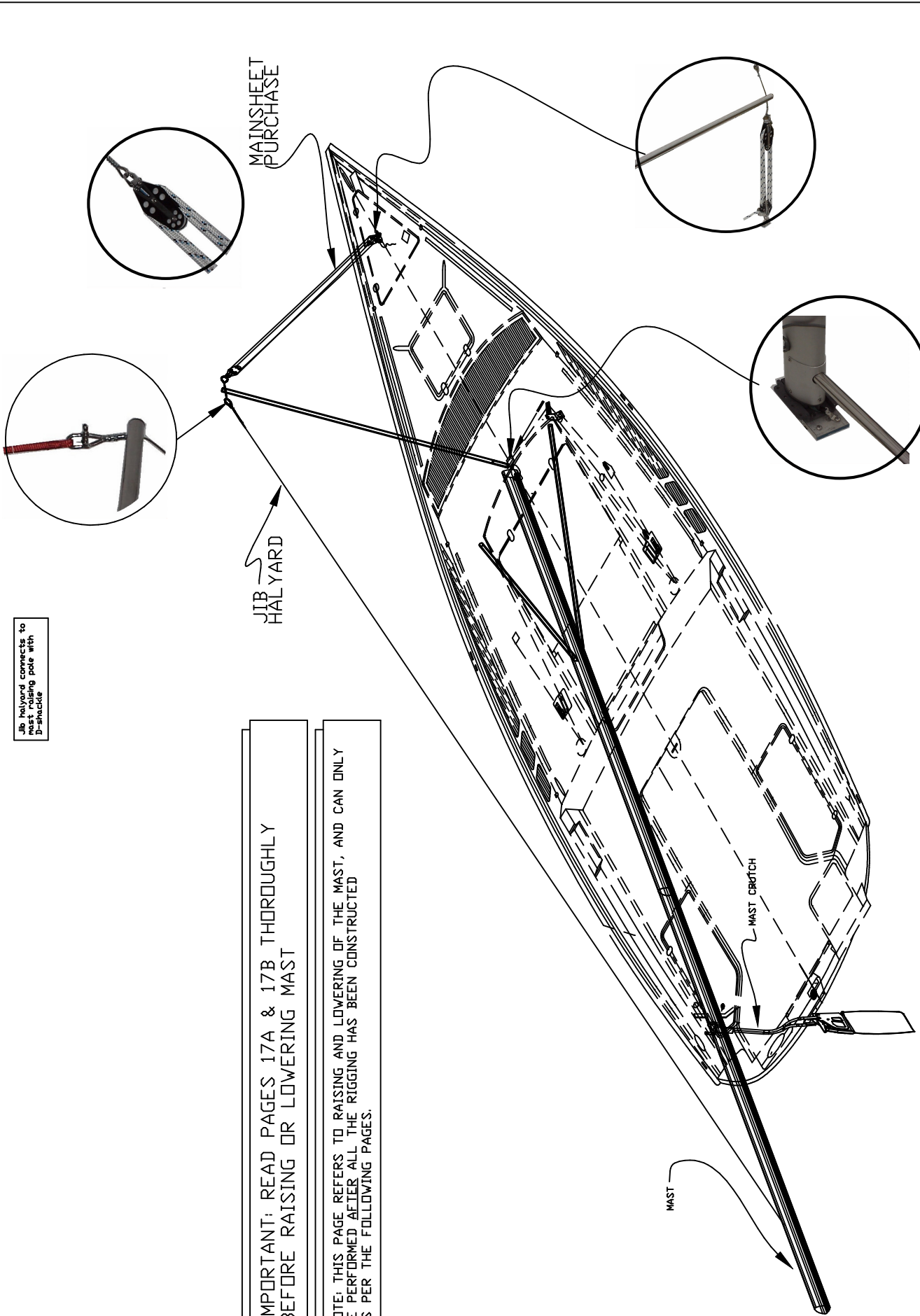

Jib halyard connects to mast raising pole with D-shackle

IMPORTANT: READ PAGES 17A & 17B THOROUGHLY BEFORE RAISING OR LOWERING MAST

NOTE: THIS PAGE REFERS TO RAISING AND LOWERING OF THE MAST, AND CAN ONLY BE PERFORMED AFTER ALL THE RIGGING HAS BEEN CONSTRUCTED AS PER THE FOLLOWING PAGES.

NOTE: NOT ALL OF RIGGING SHOWN FOR CLARITY

[View this document's address information for which HUNTER MARINE CORP. has proprietary rights.](#)
HUNTER
MAST RAISING DETAILS
 DRAWING NO. 258017C REVISED BY: None
 DRAWN BY: ENG DATE: 11/29/04

LAUNCHING & RETRIEVING PROCEDURES

LAUNCHING

1. Extend the trailer tongue, if necessary, by lowering the forward support wheel, chocking the main wheels, unplugging the electrical connection, removing the tongue positioning pin and cotter pin and sliding the tongue out to its full extended length and reinstalling the pin and cotter pin. This can be done with the vehicle still connected to the trailer, using the vehicle to slowly move the extension while a second person watches the trailer, but should at all times be done with the trailer on level ground. Whether the tongue needs extending will depend on the slope of the launch ramp and the depth of water available when the boat is backed in. In the majority of cases, for launching, the tongue may not need extending.
2. Remove any and all tie down straps and ropes securing the boat to the trailer, as well as any lines securing the rudder in the upright position or on centerline. The only attachment of the boat to the trailer should be the strap from the bow eye to the trailer winch.
3. The spar can be raised before or after launch, depending on the time available before and the docking facilities available after launch. **Beware of nearby power lines before raising spar.**
4. Attach the necessary bow and stern mooring lines and fenders if necessary. Do not lower the fenders over the side until the boat is clear of the trailer.
5. Initially slacken the trailer winch and familiarize yourself with its gear switch action and return the winch to the locked position.
6. Load all loose gear and provisions aboard by lowering the swim ladder in the transom.
7. Back the boat and trailer down the ramp until the back wheels of the vehicle are just clear of the water, Retrieve the bow and stern lines as necessary. Loosen the trailer winch and bow strap.
8. Once the boat is floating free, push the boat clear of the trailer guides to the available dock, maintaining control with the mooring lines.
9. Slowly pull the empty trailer out of the water, being careful that boat and people stay clear.
10. Park the trailer and vehicle and return to the boat.

LAUNCHING & RETRIEVING PROCEDURES

RETRIEVING

1. Raise rudder.
2. Back trailer into water. Extend trailer tongue if needed.
3. Maneuver boat between trailer guides and up to the winch.
4. Connect bow strap and with winch in correct gear, winch boat up and snug against bow stop.
5. Center boat between upright aft trailer guides.
6. Slowly pull boat from water until the weight of the boat is on the trailer.
7. Confirm alignment on trailer. Put trailer back in water if necessary to realign boat.
8. Make sure that rudder is pinned or tied in upright position so that the tip doesn't drag on ground.
9. De-rig and unstep mast if not already done. **Beware of nearby power lines when lowering mast.**
10. Tie boat to trailer, and secure mast.

GETTING READY TO SAIL

NOTE: The mast may be raised while the boat is on the trailer or after the boat is launched. However, if the mast is raised after launching, make sure (on water ballast models) that the ballast tank is full before the mast is raised. Also make sure that all halyards and reefing lines are installed using the messenger lines already run in the spar.

1. After the rig has been raised, attach the forestay turnbuckle to the most forward position of the two holes in the stem fitting. Turnbuckle should be about $\frac{3}{4}$ open. Confirm that the upper and lower shrouds are supporting the spar.

2. Remove the mast-raising pole. The mast crutch may be left on the transom or removed, as you prefer.

3. Return the mainsheet to its aft position, attaching the block with the jam the “U” bolt at the front end of the cockpit. Install the forward end of the boom to the gooseneck fitting on the mast. Tie the bottom end of the topping lift rope (the other end is fixed to the top of the mast) to the casting at the bottom of the boom, which is immediately above the mainsheet “u” bolt in the cockpit.

4. Attach the jam block of the boom vang to the stainless steel bail on the mast step with the small shackle provided. The block should be oriented so that the line exits the vee jam on the bottom aft side. Attach the upper block of the vang to the eye on the boom.

5. If not already done on the H25, lead the main and jib halyards from the exits in the spar, through the sheaves molded into the mast base (main halyard through the aft sheave), around the deck organizer blocks to the inner of the two jams on the house top.

6. Using the main halyard, center the rig in the middle of the boat by first jamming the halyard in a position so that the halyard shackle just contacts a known point on the toe rail adjacent to the spar on the port side. Transfer the halyard to the starboard side and applying the same amount of tension, see if the shackle contacts the corresponding position on the starboard toe rail. If the shackle falls short, ease the port upper shroud turnbuckle and tension the starboard, always maintaining some tension on each shroud so they are not slack. If the shackle overshoots the mark on the toe rail, ease the starboard upper shroud turnbuckle and shorten the opposite side until the halyard shackle does contact both points on the opposite toe rail uniformly.

7. After the rig is centered, set the amount of mast rake to approximately one degree of aft angle. This can be measured by hanging a weight, such as an adjustable wrench from the main halyard shackle and adjusting the halyard so the wrench is suspended immediately above the boom. With the boat level, this wrench when hanging from the main halyard above the gooseneck should be 6” (15cm) from the aft face of the mast. Adjust the forestay turnbuckle as necessary to achieve this position.

8. Tension the upper shrouds uniformly, alternately taking six turns on one, then the other, until the upper shrouds are tight. The upper shrouds maintain tension on the forestay. The tighter the shrouds are, the tighter the forestay will be and the less forestay “sag” there will be. A turnbuckle is tensioned by turning the center portion counter clockwise and loosened by turning it clockwise. The upper swage on the wire should be held with pliers, vice grips, or wrench to prevent it from turning as the turnbuckle rotates.



WARNING

ELECTROCUTION HAZARD

Make sure that the mast and rigging are clear of all overhead electrical cables when being raised or lowered or maneuvered about a launching area. Contact with an overhead electrical cable can cause severe injury or death.

GETTING READY TO SAIL

9. Tension the lower shrouds until the mast appears straight when sighted up the trailing edge, using the bolt rope slot as a guide. If the mast appears to bow to one side, ease the lower shroud on that side and tension the shroud on the opposite side until the mast appears straight.

10. Once the mast is straightened transversely, sight up the mast from the side to see if there is any fore and aft bend. The mast should be bowed forward at the spreaders by approximately 2' (5cm). Ease or tension the lower shrouds uniformly until this slight amount of bend is achieved. When finished, the lower shroud should be slightly less tight than the main shrouds. If you sail in a predominately heavy air region, slightly more mast bend, in the 3" to 4" (4-10cm) range may be desirable in order to flatten and depower the main sail.

11. After tuning the rig, install cotter pins in all turnbuckles to prevent them from backing off while sailing.

12. Install the battens in the mainsail and install the mainsail onto the boom from the forward end. Remove the stop pin in the mast and install the luff slides into the track on the back of the spar. Reinstall the stop pin to prevent the slides from falling back out again.

13. Install the out haul rope (the shorter of the two) in the boom with the messenger line provided and lead from the sheave at the back of the boom through the lower cringle at the back of the sail and aft to the end of the casting.

14. Install reefing line (the longer of the two) in the boom with the messenger line provided and lead from the sheave through the upper cringle at the back of the sail and then down to the sliding eye on the bottom of the boom. Pull enough slack into the reef line so that the sail can be fully raised unimpeded by the reef line. Tie the mainsail onto the boom with the sail ties provided.

15. Install the jib sheet onto the jib as illustrated in the owner's manual (page 42A) and lead the

sheets inside the shrouds to the lead blocks on the cabin top and aft to the jams or winches on the house top. Tie figure eight knots in the end of the sheets to prevent them from running back through the jams. Shackle the bottom of the jib to the aft of the two holes in the stemhead fitting and hank the jib onto the forestay. Bunch and tie to prevent it blowing overboard before it is ready to hoist.

16. Attach jib and main halyards to their respective sails.

17. Lower the rudder blade, if depth of water permits, to full down position. If water depth does not permit this before leaving the dock or ramp, make sure the rudder is lowered before raising sail. The rudder must be down to achieve the correct balance for the proper helm loading. A rudder, which is not lowered, will load up excessively in severe conditions preventing the helmsman from responding to puffs and thus allowing the boat to "round up". The cleat is provided to retain the blade in the upright position for the launch, retrieval and trailering. Helm "feel" can be fine tuned by adjusting the fore and aft angle of the rudder in the down position.

18. Install the tiller extension to the tiller (if not already installed from factory).

19. Raise sails, beginning with the main and then the jib while powering into the wind. Remember to lower the centerboard before you raise sail and confirm that the water ballast is full and sealed. Once each halyard, beginning with the main, is tensioned by the winch, the halyard can be pushed down into its respective jam and the halyard removed from the winch, freeing the winch for the next halyard and, in the case of the H25, ultimately for the jib sheets. However, care should be taken not to inadvertently pull the halyards out of the jams, since the sails will lower rapidly if this is done. When the sails are raised, the boat can be laid off and the engine turned off and tilted upward to clear the water.

20. Once the main is sheeted in and you are sailing upwind, confirm the main topping lift position. The

GETTING READY TO SAIL

main should be capable of sheeting in hard without the topping lift being tight. With the main sheeted in hard, the topping lift should have eight to ten inches of sag and should be adjusted accordingly. When at dock or at mooring, the topping lift can be readjusted to raise the boom to a comfortable height above the cockpit.

21. Final conformation of the mast tune as well as finer tuning, if you desire it, will take place when sailing by sighting up the spar while going upwind in about ten to twelve knots of breeze. The mast should maintain its 2" (5cm) fore and aft bend, but should also still appear straight transversely with the leeward main shroud still retaining its tension and not going noticeable slack.

If the leeward rigging does go slack when sailing, apply more tension uniformly to both shrouds by first tightening the leeward rigging three half turns and then after tacking, tension the new leeward rigging the same amount. Continue this procedure, as necessary until the leeward upper

shrouds no longer appear slack and forestay sag has been reduced. Removal and reinstallation of the turnbuckle cotter pins will be necessary to make these fine tuning adjustments.

22. Once the upper shrouds are tensioned, again sight up the spar to make sure that the middle of the spar at the spreaders is not falling to leeward or bending to weather. Adjust and uniformly retension the lower shrouds as necessary.

NOTE: Standing rigging will stretch slightly when initially loaded. Therefore, the rigging may have to be further tensioned slightly after a few sails in a strong breeze to compensate for this initial stretch. Once the mast is tuned and initial stretch is taken out, the rig should need retuning only at the beginning of each season.

23. After a day of sailing, the sails should be lowered while again powering into the wind, with the jib lowered first and then the main.

COOKING STOVE

Carefully read and understand the manufacturer's instructions prior to operating your stove. Save the instructions for review, and also to pass on to any subsequent owners.

Use only the fuel recommended by the manufacturer, and store the fuel in an approved container.

Do not smoke while working with fuel.

Immediately clean up any spilled fuel.



WARNING

EXPLOSION/FIRE/ASPHYXIATION HAZARD

- Open flame cooking appliances consume oxygen. This can cause asphyxiation or death.
- Maintain open ventilation.
- Liquid fuel may ignite, causing severe burns.
- Use fuel appropriate for type of stove.
- Turn off stove burner before filling.
- Do not use stove for comfort heating.
- Use special care with flames or high temperatures near urethane foam. Once ignited, it burns rapidly, producing extreme heat, releasing hazardous gasses and consuming a large amount of oxygen.

TOILET



CAUTION

- Do not add holding tank deodorant to the top fresh water tank
- Avoid adding holding tank deodorant through bowl. Use tank on rear of bottom tank. Slide valve must be opened fully before adding deodorant through bowl, and avoid spilling or splashing deodorants on slide valve seals or bowl. Rinse off any spilled or splashed deodorant immediately.
- Atmospheric pressure and temperature changes may cause pressure

Your Hunter 25 comes standard with a portable, self-contained marine toilet. Please refer to the manufacturer's instructions to familiarize yourself with the correct operation of your toilet.

Be sure to keep your toilet secure by connecting it to supplied hold down brackets. Add a holding tank deodorant to the lower unit of the tank, which is the holding tank. The upper unit is the fresh water tank for flushing.

Empty the holding tank at an approved permanent toilet facility by first removing the holding tank, ensuring that the valve is closed, and carrying by the built-in handle. Rinse with fresh water and reassemble.

FOR OPTIONAL H-25 MARINE HEAD, SEE PG 58A & B FOR WASTE SYSTEM DRAWINGS

PUMPS

All pumps should be checked frequently to insure proper operation. This is an especially important regular maintenance item since a properly operating pump could save your vessel from serious damage.

 CAUTION
Run pump only as long as necessary to remove water. Dry running can damage the pump motor

 WARNING
SINKING HAZARD – Ensure proper bilge pump operation

Inspect all bilge pump hoses for chafing and dry rot. See that all hose clamps are tight. Check that the bilge pump impeller area is clean and free of obstructions. Inspect electrical wiring for corrosion. Ensure that the float switch functions properly.

WATER SYSTEM OPERATION

Your Hunter is equipped with a manual pump water system, incorporating a water tank and a level actuated manual pump. After sitting for some time, the pump will need a few strokes to prime the system. Be aware of the quality of the

water on board, if you are using it for drinking or washing. Periodically, flush the water tank to keep it clean. When storing your boat for the winter, empty the water tank, and pump the lines dry.

OUTBOARD ENGINE AND MOTORING

As the outboard is an option on your Hunter, you have numerous choices of brands available to you. This motor should be between 8hp and 10hp for the H25. An engine owner's manual should be supplied with your outboard motor. This manual will contain technical specifications, running instructions and a maintenance schedule on lubricants and other important functions. For longer engine life, follow the routine maintenance schedule recommended by the manufacturer.

Run the engine at a low speed for about three minutes for warm-up operation before cruising, permitting the oil to circulate throughout the machine. Otherwise, the life of the engine will be shortened greatly. During warm-up operation, confirm that cooling water is discharged from its check port.

Under power (without sails up) your boat may be maneuvered with the rudder only, or in tight turning situations, you can shorten your turning radius by turning the outboard in the same direction as the rudder. This directs the propulsion forces in a complementary direction to the way the rudder is steering the boat. The engine will generate some "prop walk" which will exert force to push the transom relative to the direction of the rotation of the propeller. You can test your prop walk direction by putting the boat in reverse while you are parallel to the dock, and

see if the stern swings toward or away from the dock.

CAUTION

If cooling water is not discharged, and operation continues, the engine will be overheated, causing mechanical troubles

When fueling your engine, be sure to use fresh fuel. Fuel that has been in a tank too long can form gum and varnish, which can affect performance. Use oil as recommended by the manufacturer. Two stroke engines require a special oil to be either mixed with gasoline or injected from a remote tank. This lubrication is essential for the operation of the engine.

WARNING

EXPLOSION/FIRE HAZARD

- **Store flammable material in safety approved containers. Keep containers in an area designed for that purpose. Never store in an unvented space.**
- **Observe no-smoking while fueling**
- **Fill to less than the capacity of the tank. Allow for fuel expansion.**
- **Inspect fuel system regularly for leaks.**

ELECTRICAL SYSTEM

Your DC power source is a 12v battery, just as with your automobile, and it must be charged regularly. Some outboard motors include a small alternator, which will assist in recharging you battery. Otherwise you must use a battery charger. Perform regular visual inspections to insure proper water level and inspect terminals for corrosion. If your boat sits for long periods without use, it is a good idea to remove the battery(s)

And connect them with a trickle charger to keep them fully charged and ready for use.

WARNING

- Carefully follow safety instructions included with battery
- Always charge battery in a ventilated location

ENVIRONMENTAL CONSIDERATIONS

FUEL AND OIL SPILLAGE

The spilling of fuel or oil into our waterways contaminates the environment and is dangerous to wildlife. Never discharge or dispose of fuel or oil into the water. It is dangerous and unlawful. Two common types of accidental discharge are overfilling the fuel tank and pumping contaminated bilge water into the sea.

 WARNING
EXPLOSION/FIRE/POLLUTION HAZARD: Fill fuel tank to less than rated capacity. Overfill forces fuel out the tank vents, which can cause explosion fire, or environmental pollution. Also allow for fuel expansion

DISCHARGE AND DISPOSAL OF WASTE

Waste means all forms of garbage, plastics, recyclables, food wood, detergents, sewage, and even fish parts in certain waters. We recommend that you bring back everything you take out with you for proper disposal ashore.

Your marine holding tank (if so equipped) must, in many areas, be pumped out by an approved pump-out facility normally found at marinas.

EXHAUST EMISSIONS

Hydrocarbon exhaust emissions pollute our water and air. Keep your engine properly tuned to reduce

emissions and improve performance and economy.

ANTI-FOULING PAINTS

The use of anti-fouling paints is common for boats kept in water. Be aware of environmental regulations that may govern your paint choice. These regulations may affect which paint may be used, and also the application or removal. Contact your local boating authorities for more information

 WARNING
EXPLOSION/FIRE/HAZARD: Ventilate when painting or cleaning. Ingredients may be flammable and/or explosive.

CLEANING CHEMICALS

Cleaning chemicals should be used sparingly and not discharged into waterways. Never mix cleaners and be sure to use plenty of ventilation in enclosed areas. Do not use products that contain phosphates, chlorine, solvents, non-biodegradable or petroleum-based products.

Common households cleaning agents may cause hazardous reactions. Fumes can last for hours, and chemical ingredients can attack people, property and the environment.

This Page Intentionally Left Blank

INSTRUCTIONS FOR PREPARATION FOR BOTTOM PAINTING

WARNING!

Do not use any sanding, sandblasting or other abrasive preparation of the bottom, as this will void your hull blistering warranty. See the war-

ranty information at the beginning of this manual.

BOTTOM PAINTING

Choose a bottom paint system that suits the environment in your area.

Follow the procedure recommended by the manufacturer of the paint, while making sure not

to void the Hunter Hull Blistering Warranty. The procedure for preparing and painting the bottom varies between paint manufacturers, but should always include dewaxing, etching and sometimes priming of the surface.

EPOXY BARRIER COAT

Sanding of the gel coat bottom surface will be permitted should a customer wish to have an epoxy barrier coat applied to the hull, (example Interlux Interprotect 1000, 2000, West System or VCTar). This will not void the Five-Year Blister Warranty.

Hunter Marine refers to epoxy barrier coatings as mentioned above, not epoxy primer paints. If an epoxy barrier coat is applied to a Hunter vessel, it must be registered with the Warranty Department prior to application of the product. If the dealer applies bottom paint only, sanding

will not be allowed and the no sanding system must be used.

	 WARNING	
Cleaning agents and paint ingredients may be flammable and/or explosive, or dangerous to inhale. Be sure to use adequate ventilation, and appropriate safety clothing. (gloves, safety glasses, respiration, etc)		

ENGINE MAINTENANCE

Follow the fuel and lubrication requirements in the engine manual provided by the manufacturer. Check oil levels prior to starting, and use lubricants as recommended by the engine manufacturer. Always check fuel lines and connections for possible leaks, which may create a dangerous situation.

If you use your outboard in salt water, wash down the exposed drive unit after every use to limit corrosion. Also, it's a good idea to attach a water hose to a flushing device on an outboard and completely flush out the raw water cooling system. Regularly check the propeller and drive unit for any damage or other signs of serious

wear. Propeller damage will reduce performance, as well as contribute to other potential engine problems.

 **WARNING**

EXPLOSION/FIRE HAZARD

- *Fuel system connections that are too loose or too tight can leak, resulting in fuel loss, environmental pollution and explosion or fire hazards.*

ELECTRICAL SYSTEMS

The electrical system is a 12-volt, negative ground installation. On a weekly basis, the owner should inspect batteries, terminals and cables for signs of corrosion, cracks, and elec-

trolyte leakage. Battery terminals are to be kept clean and greased. Refer to specific instructions on batteries, wiring diagrams, and electronics.

 **WARNING**

California Proposition 65

Diesel engine exhaust and some of its constituents are known to cause cancer, birth defects, and reproductive harm in the State of California.

 **WARNING**

California Proposition 65

Battery posts, terminals, and related accessories contain lead and lead compounds; chemicals known to the State of California to cause cancer and reproductive harm.

Wash hands after handling!

PLUMBING SYSTEM

All pumps should be checked frequently to insure proper operation. This is an especially important regular maintenance item since a properly operating pump could save your vessel from serious damage.

Inspect all bilge pump hoses for chafing and dry rot. See that all hose clamps are tight. Check

that the bilge pump impeller area is clean and free of obstructions.

Inspect electrical wiring for corrosion. Ensure that the float switch functions properly.

PROTECTING YOUR RIGGING

No matter how good your rigging is, without careful inspection and proper maintenance it is subject to fatigue, wear, discoloration, and therefore, product failure. Remember: regular inspection and cleaning will increase the life of your investment and secure your rigging. We suggest the following:

- Always rinse your rigging with fresh water after sailing, especially salt-water sailing. Salt can create corrosion pits, causing cracks and deterioration.
- Clean with a water-soluble chlorine-free detergent. Nonabrasive cleansers are best for hard white vinyl coated cables.
- Inspect rigging for stains. Rust stains may indicate stress cracks or corrosion. Remove stains with synthetic or brass pads. Never use steel wool pads.
- Look for broken wires - a sign of fatigue in rigging. Replace standing rigging if wires are broken.
- Never mix stainless steel and galvanized metals on cable, fittings, pins, cotter keys, etc. If mixing dissimilar metals, electric currents may conduct between metal causing rapid deterioration
- After unstopping, make sure to release all standing rigging to avoid bending, crushing and kinking.
- Store rigging in a dry place. Never store in a plastic bag, which can cause corrosion.

TRAILER MAINTENANCE

BEFORE USING YOUR TRAILER

1. Check all bolts and nuts for tightness, including the lug nuts for the wheels.
2. Check to insure that all lights are working properly.
3. Always maintain the tires' recommended air pressure.
4. For improved tire life, have your tires spin-balanced by a qualified tire service center.
5. When the trailer has been hitched to your vehicle, remove the two-speed winch handle before departing.
6. Always check hitch and safety chain connection and boat tie downs prior to departing.

PROTECTING AND MAINTAINING YOUR TRAILER

1. Before launching your boat, we recommend that the light harness be disconnected from your vehicle with enough time to allow bulbs to cool. This will greatly extend the life of your bulbs.
2. This trailer has a galvanized frame, however, some parts including the brakes, axles, hubs, springs, U bolts, and plates are not galvanized. Most of these parts have been sprayed with a high gloss black rust resistant paint, plus a clear coating. After launching, (especially in salt water locations), rinse your trailer, including the painted components. As a continuing measure to protect your trailer, you should from time to time, refinish and repaint surfaces that show signs of rusting.
3. Periodically and regularly check your wheel bearings for sufficient grease and tightness. The more launching you do, the more likely for the need to re-grease these bearings.

Proper maintenance and care will help insure more trouble free trailering for you.

IMPORTANT: Be sure to thoroughly familiarize yourself with the trailering regulations in your state and in any others through which you will be traveling with your boat. Regulations vary from state to state regarding the trailering of sailboats, governing both the width of the load and the length of mast overhang at the rear of the trailer. Special permits may be required, and other regulations may apply. Consult your local authorities for more information.

GENERAL CARE

CLEANING FIBERGLASS SURFACES

Fiberglass surfaces should be cleaned regularly. Normal accumulations of surface dirt can be removed simply by occasional rinsings with water. If you operate your boat in salt water, more frequent rinsing will be required. To remove stubborn dirt, grease or oil, use a mild detergent and a soft brush. Rinse with fresh clean water. Avoid the plexiglass companionway slider, windshield, deck hatches and fixed ports when using a deck brush, since these surfaces can scratch.

It is a good idea to wax the fiberglass once or twice a year to maintain a deep, glossy appearance. Your lo-

cal marine supply should be able to provide an appropriate wax.

 WARNING	
EXPLOSION/FIRE HAZARD <i>Cleaning agents and paint ingredients may be flammable and/or explosive, and dangerous to inhale. Be sure to use adequate ventilation, and appropriate safety clothing (gloves, safety glasses, respirator, etc.)</i>	

CLEANING ACRYLIC

Use only mild soap and water to clean acrylics. Do not use products containing solvents such as ammonia, which is found in many window cleaners.

 CAUTION	
<i>Use care when cleaning acrylic. Dry cloth and many glass cleaners will scratch. Solvents will attack the surface.</i>	

SAIL CARE

Sunlight is a sail's worst enemy, so **cover the mainsail when not in use**. An ultraviolet guard, fitted down the leech of a roller headsail will protect the exposed part from the weathering effect of the sun and from dirt and grit.

Mildew, can be prevented by storing sails dry and by hand washing twice a season. Check all sails regularly for chafe, particularly where they chafe on

deck fittings or rigging, at reef points, batten sleeves and the foot of the headsail. Sail batten pockets should be inspected on a regular basis.

To stow the mainsail, start at the leech and flake it onto the boom, left and right, in about 18-in. (46 cm) folds, while pulling the leech aft. Secure with a sail tie and continue to the luff. Lash to the boom with sail ties or shock cord.

GENERAL HARDWARE MAINTENANCE

Check all fittings regularly to be sure screws are tight. Occasionally lubricate (use silicone lubricants) all moving parts on such fittings as blocks, turnbuckles and cam cleats, as well as the locking pins of snatch blocks, track slides, spinnaker poles, etc. Inspect cleat and fairleads for roughness and

smooth with fine-grained emery paper if necessary. Also, replace any missing or damaged cotter pins in turnbuckles and shackles, and either tape them or use them or use protective covers manufactured for that purpose. Grease winches a minimum of once yearly.

WINCH MAINTENANCE

Follow the maintenance instructions prescribed by winch manufacturer. We recommend a minimum of

an annual cleaning and light greasing.

VINYL

These patterns, like all upholstery fabrics and vinyl, require a regularly scheduled cleaning program. A thorough cleaning should be administered on a daily, weekly or monthly basis depending on use and exposure to dirt and/or staining agents. It is important to begin treatment of a stain as soon as possible after a spill. It is important that efforts begin immediately after a spill to remove any potential staining agent. It is advisable to clean these products as soon as the first signs of dinginess occur, otherwise, delaying clean up will require a much greater effort to restore the product to its original appearance.

Regular cleaning requires the use of a mild cleaner such as Murphy's Oil soap and water. In situations where the vinyl has not been washed regularly and there is a build up of dirt, stronger vinyl cleaners such as Simonize's Tuff Stuff or Turtle Wax's vinyl/fabric cleaner are recommended. We do not recommend the use of any other cleaners. The use of cleaners

other than those recommended may result in irreparable damage to the product.

In order for the above listed cleaning solutions to work effectively on stubborn stains, please allow time for the cleaning solution to soak in thoroughly. Be sure to remove the cleaning solution before it has time to dry. Regardless of the type of cleaner used, it is necessary to finish up with a thorough rinse using fresh water on a clean sponge or rag. A soft bristled nylon or natural fiber brush can be used to remove built-up dirt and staining agents.

Finally, please remember that all our fabric grain vinyls require a greater cleaning effort to maintain than comparable smooth grain vinyls. These products will provide an attractive and durable alternative to conventional fabrics and vinyls if properly maintained. One must realize that the proper installation and use of our fabric grain vinyls require additional attention to the establishment and maintenance of a well thought out cleaning program.

FABRIC CARE

Vinyl: Clean with mild soap and water. Wipe with vinyl or upholstery cleaner monthly, and especially before and after storage.

Leather: Mild soap water. Blot dry. Do not scrub as this will stretch and scratch. Wipe with leather cleaner/oil to preserve and help prevent cracks before and after storage.

Fabric: Blot dry. Do not machine wash. Use only mild soap and water. Wipe with a clean white cloth. If stain persists, dry clean. Be sure to treat cleaned surfaces with scotch guard.

Stretched or loose covers may be steam cleaned. If foam is removed, it will restuff more easily if wrapped with thin plastic.

Storage: Cover with airflow fabric to reduce dust buildup. Do not use plastic, as this will cause cushions to sweat and mildew.

Cushions: If wet, prop cushions vertically to promote airflow around each cushion. Cushions can be cleaned by most dry cleaners. **Dry clean only.**

ELECTROLYSIS AND GALVANIC PROTECTION

Salt water allows electric current to flow from anodic to cathodic material. For any two metals from two components, their relative positions in the galvanic rating table, will determine which loses material (the anode) and which remains largely undisturbed (the cathode). The distance between the two metals on the galvanic table determines the rate of wear. Thus a sacrificial zinc anode is often fitted to the underwater area of a boat to attract any destructive currents away from bronze or steel propeller shafts, for example.

It is not enough to know that your boat does not suffer from electrolysis; a newcomer in the

adjacent marina berth may start a too-friendly association with metal components on it. An easy place to fit an anode is on the propeller shaft, or covering the propeller nut. The anode should not be painted; this would render it ineffective.

To prevent electrolysis in seawater, the difference between the voltages of the two adjacent metals should not exceed 0.20 V. For example, zinc and carbon steel used together risk corrosion, while lead and active stainless steel are compatible. Metals with a high voltage corrode faster and need a larger area to diffuse the electrochemical reaction.

TEAK CARE

Teak wood is a high quality, extremely durable wood with a high oil content. In order to help you protect the original beauty of your teak interior, we have sealed the wood with a 3 to 4 coat system of high quality Seafin Teak Oil, manufactured by Dalys. This material is penetrating oil that dries to a low sheen to seal and

protect the wood from moisture and weathering. It creates a durable, nonslip surface to repel water and resist wear. It won't chip, peel or blister. It reduces work and maintenance cost because it is easy to repair and maintain and repair. With proper maintenance it will outlive urethane varnish on interior and even exterior surfaces.

MAINTENANCE

When oiled surfaces require renewing, simply wipe the surface area free of loose dirt, dust or other contaminants. Dampen a cloth with the

Seafin Teak Oil and wipe on. Let stand for 5-15 minutes, then polish dry. If your dinette table has an epoxy finish, clean with furniture polish.

REPAIRS

When woodwork is damaged from scrapes or abrasions that go into or thru the finish, take the following steps:

1. Take 180 to 200 grit wet/dry sand paper to smooth out rough spots.
2. Wipe clean of dust and dirt with a clean rag. Note: before applying oil, wood surface must be dry.
3. Wipe or brush on oil, allow to penetrate 5-15 minutes while surface is still wet.
4. Sand until smooth with 400A wet/dry sandpaper.

5. Wipe dry with a clean rag. Allow 8-12 hours drying time.
6. Apply second coat, sand, and repeat procedure.

This procedure may be repeated as many times as needed to bring damaged area back to its original finish. If you have trouble with getting the same sheen, you may use a soaked and rung out cloth to apply a very light coat to get an even sheen.

STORAGE/WINTERIZATION

IMPORTANT

Winter storage is recommended to be done in one of the following three ways, either: 1) by blocking the boat via a cradle 2) with chained stands on level ground; or 3) by storing the boat in the water with a bubbler system to prevent icing. Damage to your boat, including engine misalignment caused by twisting, is not covered by the warranty.

SAILS

Sails should be properly folded and stowed in a dry, well-ventilated place. Many sailboat owners send their sails back to the sail manufacturer at the end of each season. The sail maker will check the stitching and sailcloth for wear and store the sails until the start of the next season.

ELECTRICAL

Remove battery from boat (Refer to Engine Manual) and charge. It is a good idea to also remove the electronics (radio, radar, etc) and store in a safe place.

CUSHIONS

Cushions should be removed and stored at home if possible. If not, prop them vertically to promote air flow around each cushion. *Dry clean only!*

HATCHES

Tenting the deck during storage will help prevent ice from forming and damaging hatches and deck fittings. The installation of a passive vent will help with ventilation while the boat is in storage.

WATER SYSTEM

Open a faucet and allow the pump to empty the tank. Then add approximately two gallons (7.6L) of non-toxic anti-freeze solution to the tank and repeat the pumping out procedure.

A second method is to disconnect the hoses at the pump, allowing them to drain. Find the lowest point in the system and disconnect the fitting. Open all faucets to allow the lines to drain. If possible, use a short of hose on the faucet to blow through the lines to clear all water. A diluted solution with baking soda will help freshen the system.

WATER SYSTEM

Open valve and drain fully leave valve open during lay-up time.

TOILET AND HOLDING TANK

Drain and flush toilet. Using non-toxic anti-freeze in a 50/50 mixture with water, pump through toilet and into holding tank.

OUTBOARD ENGINE

Take it home and store it in a safe place. Be very careful storing the gas tank as the gasoline is very

flammable. Refer to Engine Manual for specific maintenance schedule.

INBOARD ENGINE

Winterizing Fresh Water Cooled Diesel Engines

1. Drain crankcase and transmission and refill with fresh lubricant as specified in Engine Manual.
2. Drain and clean all fuel filters and change elements, gaskets, and seals. Bleed all air from fuel systems.
3. Start engine and bring up to operating temperature.
4. Close the sea cock, remove the raw water pickup hose from the raw water pump and immerse one end into a 5-gallon (19L) bucket of anti-freeze solution. Start engine and run till anti-freeze solution comes out exhaust stack or until bucket is empty. Attach the raw water pickup hose to the raw water pump. Tighten all clamps. **NOTE: This procedure bypasses the sea strainer to prevent anti-freeze from crystallizing in sea strainer, which warranty will not over.**
5. Loosen water pump and alternator belts to lessen tension on belts during winter.
6. For engines equipped with a hand crank: pull compression release levers and turn engine slowly with the hand crank. Slowly pour about 2 ounces of engine oil into the intake pipe or manifold while hand cranking the engine. This will allow for a thin coat of oil on the valves and upper cylinder. **DO NOT USE** starter to turn engine or serious engine damage may result.
7. Tape the openings of the intake and exhaust manifolds with duct tape to help prevent corrosion of the upper cylinder during lay-up.
8. Scrape all rust or corrosion from exposed metal parts and surfaces. Scrub all metal surfaces with detergent and rinse thoroughly. Paint any bare metal.
9. Place a dust cover over engine. Do not leave the engine exposed to rain and sea breeze.
10. Disconnect the battery cables; remove the battery from the boat. Clean the terminal ends and battery with a solution of baking soda and water, and

STORAGE/WINTERIZATION (CONT.)

then rinse thoroughly with clean water. Apply a light coat of grease on the terminal end of the battery and cables. Store the battery in a cool dry place. Use a trickle charger to keep battery charged. Do not charge battery near any open flame or a confined area.

CAUTION: Wear safety goggles and rubber gloves to protect your skin.

Winterizing Raw Water Cooled Diesel Engines

1. Drain crankcase and transmission and refill with fresh oil as specified in the engine manual. Change oil filters.

2. Close seacock, remove raw water pickup hose from water pump, attach 4-foot (1.2m) length of hose to water pump and immerse in a 5-gallon (19L) bucket of **biodegradable** anti-freeze solution. Remove hose from engine or manifold that leads to exhaust elbow. Attach about a 4-foot length of hose and immerse one end in the bucket of **biodegradable** anti-freeze solution. Start engine and run until water begins to warm up (about 3-5 min.) and the thermostat opens. Stop engine. Replace hose that leads to exhaust elbow. Start engine and let run till water comes out exhaust pipe. Stop engine, remove hose from water pump to bucket, attach hose from seacock to water pump and tighten all hose clamps.

NOTE: this procedure bypasses the sea strainer to prevent anti-freeze from crystallizing sea strainer, which warranty will not cover.

3. Loosen water pump and alternator to lessen tensions on belts during winter.

4. Drain and clean all fuel filters and change elements, gaskets and seals. Bleed all air from fuel systems.

5. Pull compression release lever and turn engine slowly with hand crank. Slowly pour about 2 ounces of engine oil into the intake pipe or manifold while engine is turning.

DO NOT USE the starter to turn engine or serious engine damage may result.

6. Tape the openings of the intake and exhaust manifolds with duct tape to help prevent corrosion of the upper cylinder during lay-up.

7. Scrape all rust or corrosion from exposed metal parts and surfaces. Scrub all metal surfaces with detergent and rinse thoroughly. Paint any bare metal.

8. Place a dust cover over engine. Do not leave engine exposed to rain and sea breeze.

9. Disconnect the battery cables; remove the battery from the boat. Clean the terminal ends and battery with a solution of baking soda and water and rinse thoroughly with lean water. Apply a light coat of grease on the terminal end of the battery and cables. Store the battery in a cool dry place. Use a trickle charger to keep battery charged. Do not charge battery near any open flame or in a confined area.

CAUTION: Wear safety goggles and rubber gloves to protect your eyes and skin.

DEPARTURE FROM THE BOAT

The check list for leaving a boat unattended is very important because items overlooked often will not be remembered until you are far from the boat and corrective actions are impractical or impossible. Primary choices for this list are items relating to the safety and security of the unattended craft: turning off fuel valves, properly setting electrical switches, pumping out bilge and leaving the switch on automatic (or arrange for periodic pumping out). **It is recommended that the power be turned off when leaving the boat.** Other departure checklist items are securing ports, windows, hatches and doors.

ROUTINE MAINTENANCE

Routine maintenance checklists should include items based on how much the boat is used (usually in terms of engine hours) and on calendar dates (weekly, monthly or seasonal checks). Typical of the former are oil level checks and changes, and oil and fuel filter changes.

On a calendar basis the lists should note such matters as electrolyte levels in storage batteries, pressure gauges on dry chemical fire extinguishers, and all navigation lights. Check the operation of automatic bilge alarms or pump switches by running water into the boat. Periodically close and open sea cocks several times to ensure their free and easy operation in case they are needed in an emergency. Equipment and supplies carried on board for emergencies should be inspected for any signs of deterioration.

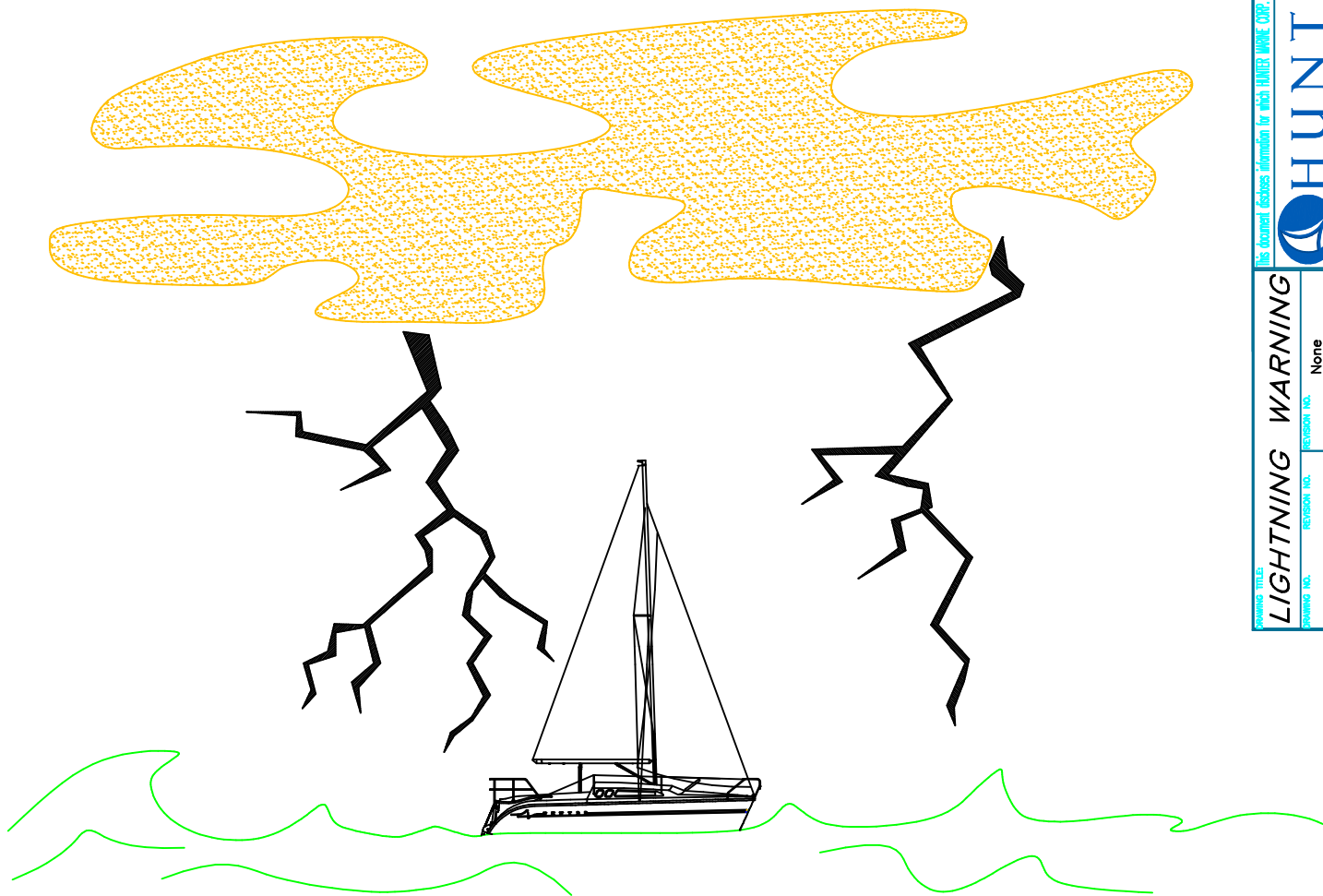

LIGHTNING STORM WARNING:

1. ALL WHIP ANTENNAS SHOULD BE TIED DURING STORM.

2. PRECAUTIONS: DURING LIGHTNING STORMS: A. THE SHIPS OCCUPANTS SHOULD TAKE SHELTER INSIDE A CLOSED AREA OF THE BOAT. EXAMPLE: BELOW DECK. B. OCCUPANTS SHOULD NOT HAVE ANY BODY PARTS IN THE WATER. C. AVOID CONTACT WITH ANY COMPONENTS OF THE L.P.S. AND D. AVOID ALL CONTACT WITH ANY METAL OBJECTS.

3. IF LIGHTNING SHOULD STRIKE THE SHIP, INSPECT ALL ELECTRONICS, ELECTRIC GEAR, COMPASS AND L.P.S. SYSTEM FOR POSSIBLE DAMAGE. RECALIBRATE AS NECESSARY. NOTE: BEGIN CHECKING ELECTRONICS AFTER THE THREAT OF LIGHTNING HAS PASSED.

NOTE: THIS BOAT IS NOT PROVIDED WITH ANY LIGHTNING PROTECTION SYSTEM. SEEK A QUALIFIED ABYC CERTIFIED ELECTRICIAN IF SUCH SYSTEM NEEDS TO BE ADDED TO THE BOAT.

FAILURE TO FOLLOW PRECAUTIONS MAY RESULT IN SEVERE INJURY OR DEATH

This Page Intentionally Left Blank

This document contains information for which HUNTER MARINE CORP. has proprietary rights.



STANDARD SAILPLAN

FORMER TITLE	None	DATE	11/29/04
DRAWING NO.	258036	DESIGNER	ENG

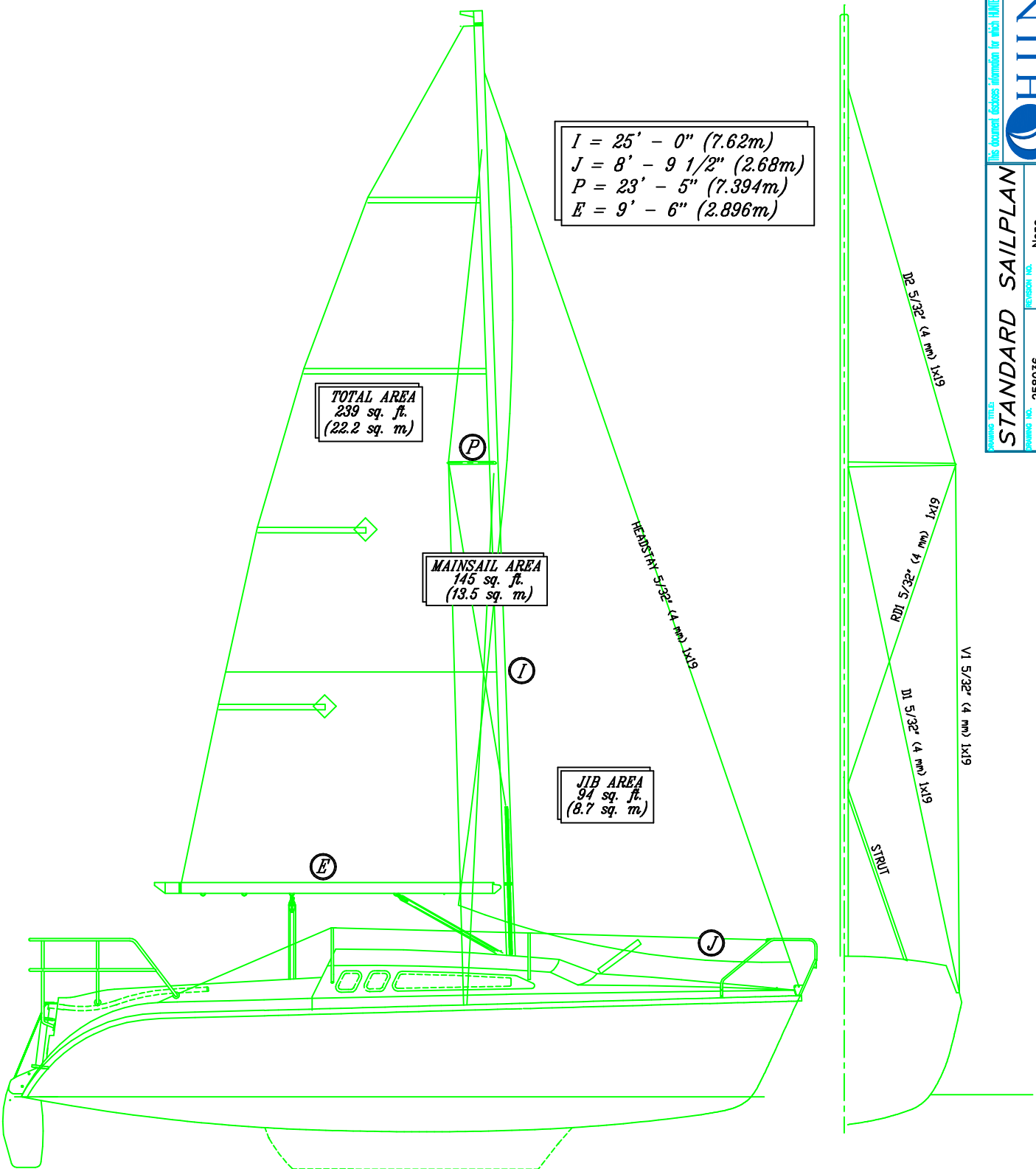

DIMENSIONS, CAPACITIES, ETC.

HUNTER 25

LENGTH OVERALL (LOA).....	24' 6"	7.47m
LENGTH OF WATERLINE (LWL).....	22' 1"	6.72m
BEAM (MAX).....	8' 5 1/2"	2.58m
DRAFT	2' 0"	.61m
DISPLACEMENT	3700 lbs	1678 kg
SAIL AREA (ACTUAL W/ STANDARD SAILS).....	239 sq. ft.	22.2 sq.m
I.....	25' 0"	7.62m
J.....	8' 6"	2.59m
P.....	23' 5"	7.39m
E.....	9' 6"	2.896m
MAST HEIGHT (FROM WATERLINE).....	31' 8"	9.65m
WATER CAPACITY.....	10 U.S. gal.	37.9 liters
HOLDING TANK CAPACITY (PORTA-POTTY).....	2.8 U S gal.	10.5 liters
HOLDING TANK CAPACITY (OPT. MARINE HEAD).....	13 U.S. gal	49.2 liters
FUEL TANK CAPACITY	OPTIONAL W/ OUTBOARD	
BATTERY CAPACITY	DEALER SUPPLIED	
ELECTRICAL VOLTAGES.....	SEE ELECTRICAL DRAWINGS	
OPT. OUTBOARD ENGINE.....	UP TO 10 H.P.	7.5 kw
MAXIMUM LOADING.....	8 PEOPLE	840 kg
		(INCLUDING LUGGAGE)

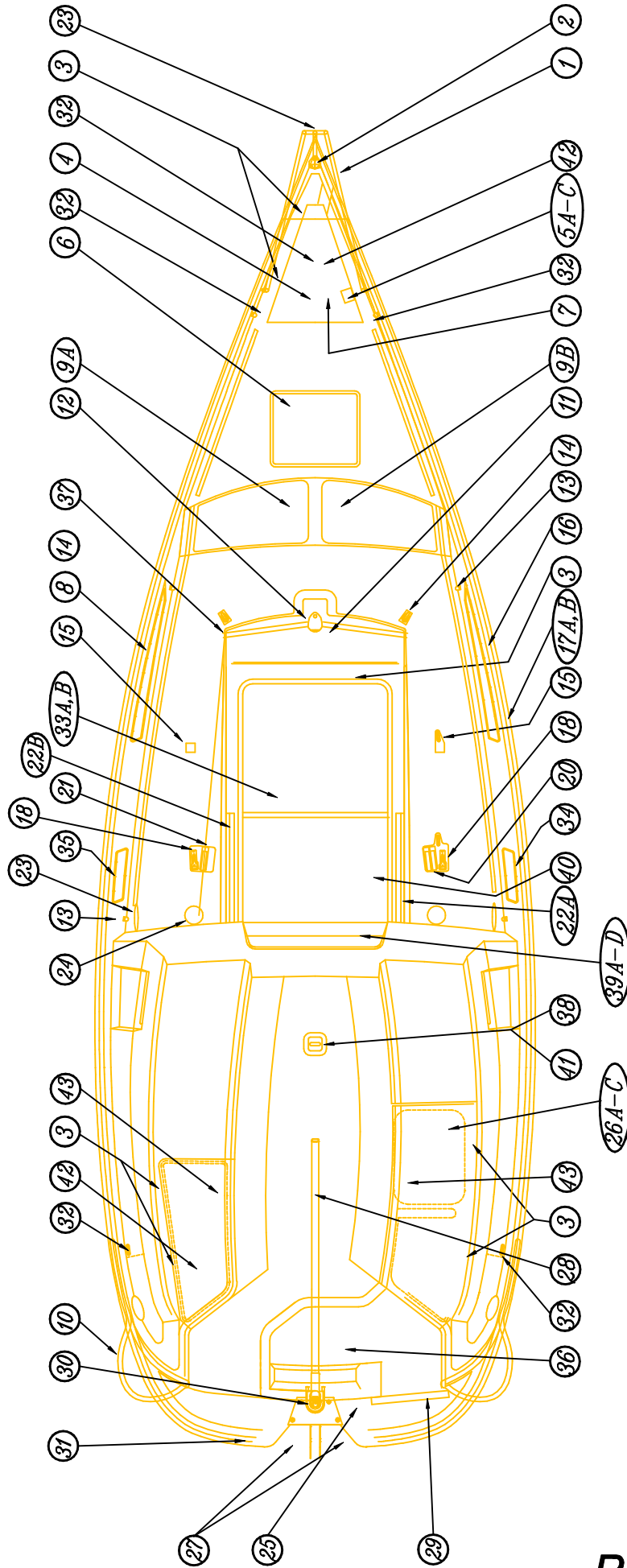

DECK HARDWARE LIST

ITEM	QTY	DESCRIPTION	DWG#	COMMENTS
1	1	BOW RAIL	H23B2022	HUNTER
2	1	BOW ROLLER (OPTIONAL)		SEA DOG
3	8	HINGE		#1167
4	1	ANCHOR DEAD END U-BOLT		3/8" SS U-BOLT
5A	1	ANCHOR LOCKER LATCH		S.S.
5B	1	STRIKER PLATE		S.S.
5C	2	EYE STRAP (CHROME)		FOR BUNGEE CORD
6	1	FRONT HATCH	H23A2415	FIBERGLASS
7	1	ANCHOR LOCKER LID	H23A2417	SAME AS H23.5
8	1	PORT FWD WINDOW		
9A	1	PORT FORWARD WINDSHIELD		
9B	1	STRBD FORWARD WINDSHIELD		
10	2	STERN RAILS		
11	1	THREE PRONG PLUG		
12	1	MAST BASE		
13	4	FWD STANCHION		
14	2	HALYARD CHEEK BLOCKS		
15	2	JIB LEAD BLOCKS		
16	1	STBD FWD WINDOW		
17A	4	CHAINPLATES	H23B2028	3/8" U-BOLTS
17B	2	CHAINPLATE BACKUP PLATES		1/4" X 3/4" S.S.
18	2	CLAM CLEATS		
19	4	PAD-EYE		
20	1	XA/2 SHEET STOPPER		EASY LOCK DOUBLE
21	1	XA/1 SHEET STOPPER		EASY LOCK SINGLE
22A	1	SLIDER RETAINER		STBD. SIDE
22B	1	SLIDER RETAINER		PORT SIDE
23	1	BOW LIGHT		BI-COLOR #62246B
24	2	HALYARD WINCHES		LEWMAR 6A
25	1	STERN LIGHT		#62243B
26A	1	WHITE HATCH		#927-2100
26B	1	TRIM RING		#926 GREY ENT.
26C	1	SCREEN		#GS927-28
27	2	RUDDER STOPS		
28	1	TILLER ARM		RONSTAN
29	1	ENGINE MOUNTING BRKT.		
30	1	RUDDER ASSEMBLY		
31	1	SWIM LADDER		
32	5	6" FOUR HOLE CLEATS		S.S.
33A	1	SEAHOOD		GLASS PART
33B	2	SEAHOOD SUPPORT LEGS		S.S.
34	1	PORT LIGHT-SMOKE		N. FLA. GLASS & MIRROR
35	1	PORT LIGHT-FROSTED		N. FLA. GLASS & MIRROR
36	1	GAS TANK ACCESS		GLASS PART
37	2	STRUT BRACKETS	24030002	MADE BY HUNTER
38	1	MAINSHEET U-BOLT WITH NUTS		3/8" S.S.
39A	1	HATCH BOARDS		
39B	1	HATCH BOARD HASP		CHROME
39C	1	STBD. HATCH BOARD TRACK		KING STARBOARD
39D	1	PORT HATCH BOARD TRACK		KING STARBOARD
40	1	C-WAY SLIDER		
41	1	MAINSHEET ASSEMBLY		SCHAEFFER35-03
42	3	BUNGEE CORD 20"		FOR DECK HATCHES
43	4	RUBBER BUMPERS		

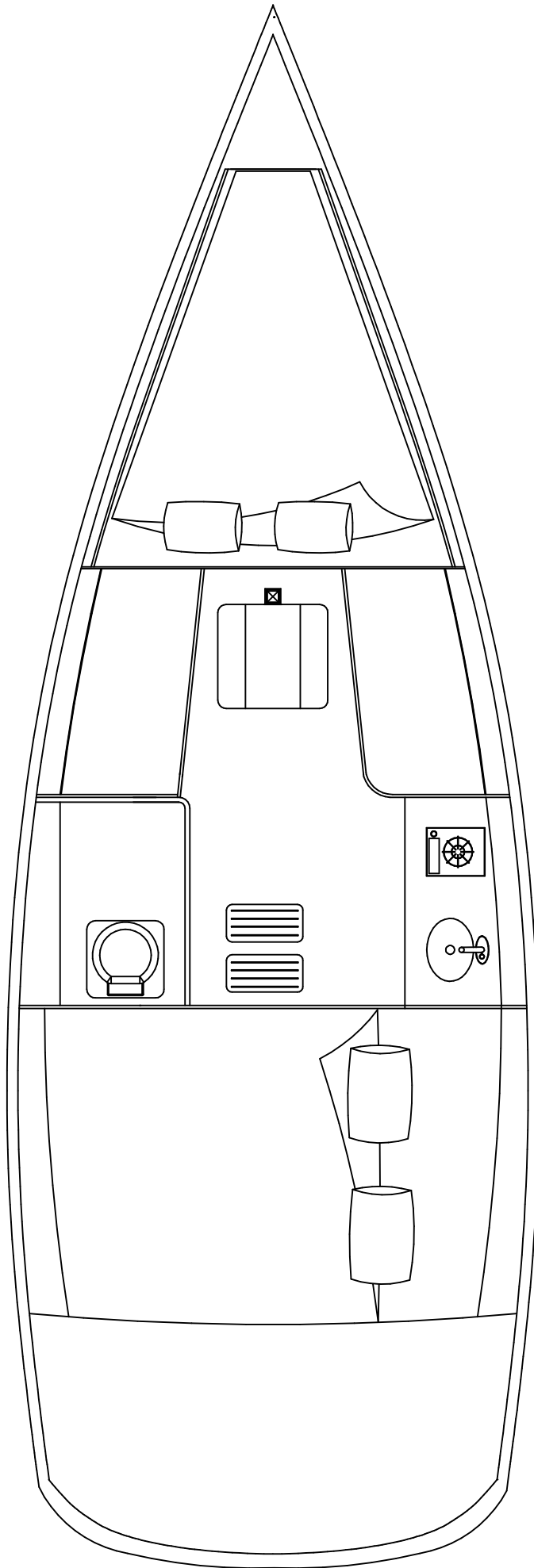

This document contains information for which HUNTER MARINE CORP. has proprietary rights.



INTERIOR LAYOUT

DRAWING NO.	258040	REVISION NO.	None
DRAWN BY:	ENG	DATE:	11/29/04

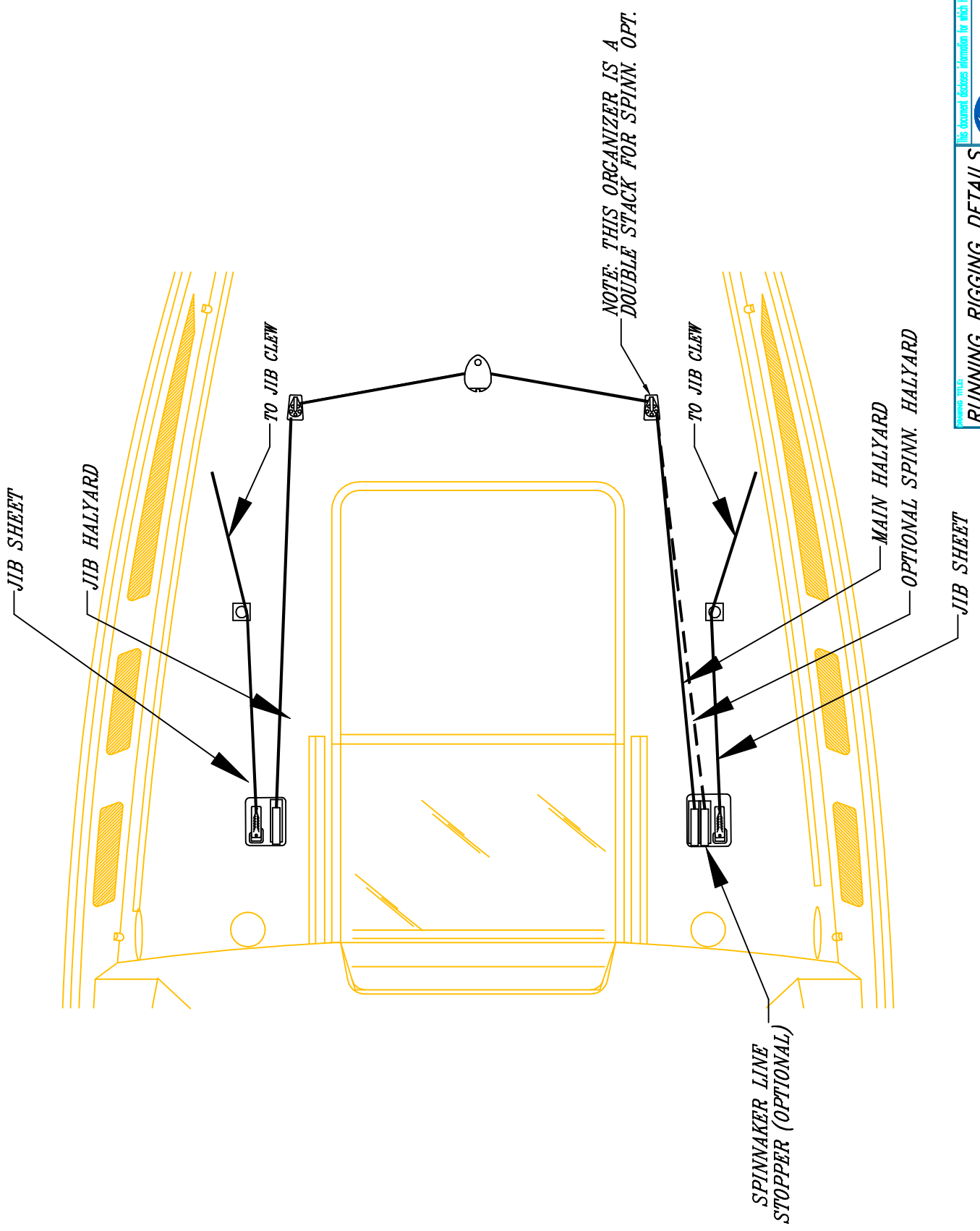

[This document contains information for which HUNTER MARINE CORP. has proprietary rights.](#)
HUNTER
RUNNING RIGGING DETAILS
 DRAWING NO. 258041 REVISION NO. None DATE 11/29/04
 DRAWN BY: ENG

This document contains information for which HUNTER MARINE CORP. has proprietary rights.



JIB SHEET ARRANGEMENT

PERSON NO.	None
DRAWING NO.	258042A
DATE	11/29/04
DRAWN BY	ENG

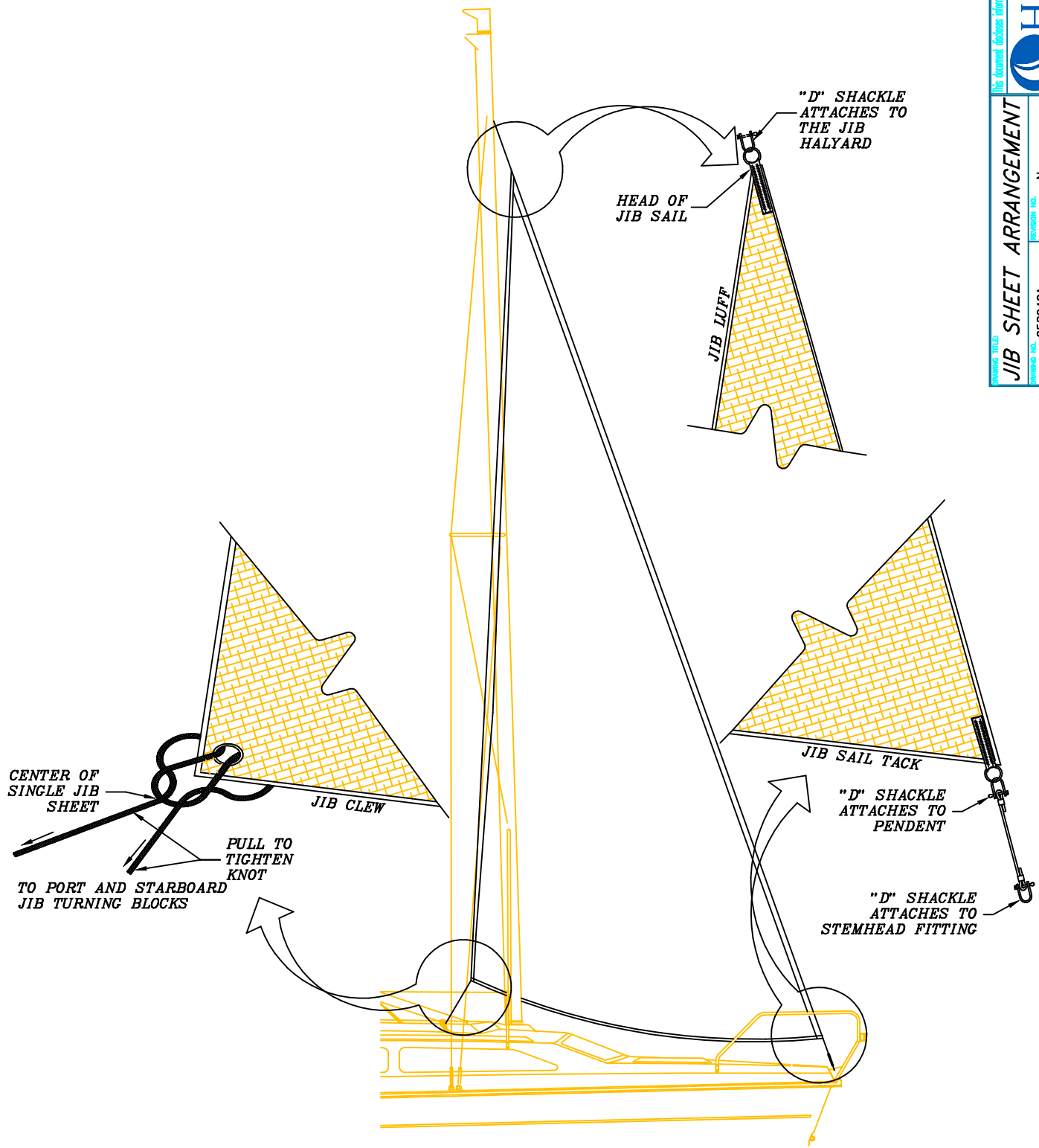

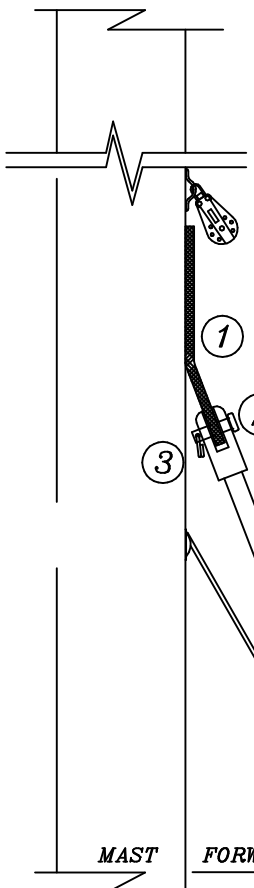

SIDE VIEW

- ① FORESTAY/SHROUD TANG
- ② CLEVIS PIN
- ③ CLEVIS PIN SPLIT RING
- ④ FORESTAY
UPPER END = MARINE EYE
LOWER END = MARINE EYE
- ⑤ UPPER FURLING SWIVEL
- ⑥ FORESTAY PENDENT
- ⑦ JIB HEAD
- ⑧ JIB TACK
- ⑨ FORESTAY TURNBUCKLE
- ⑩ FURLING DRUM
- ⑪ STEMHEAD FITTING

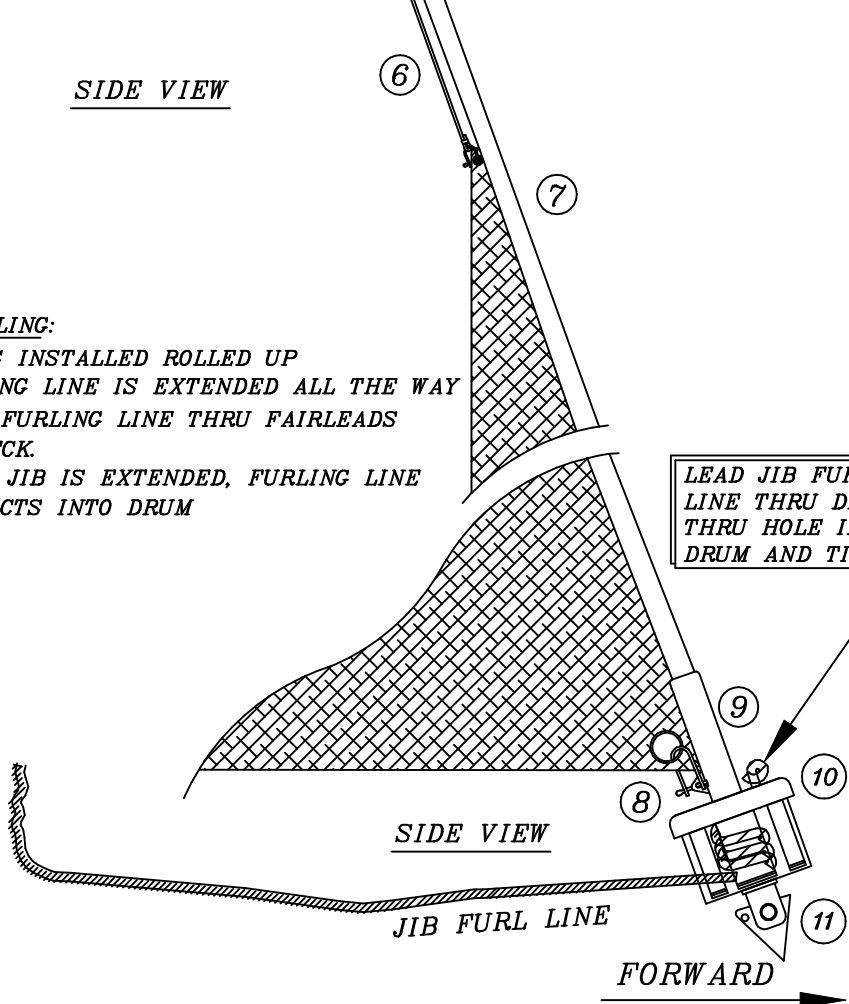

SIDE VIEW

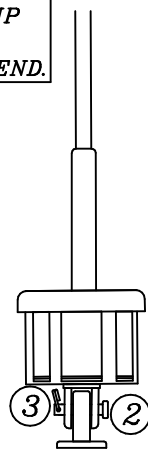

FRONT VIEW

JIB FURLING:

1. JIB IS INSTALLED ROLLED UP
2. FURLING LINE IS EXTENDED ALL THE WAY
3. LEAD FURLING LINE THRU FAIRLEADS ON DECK.
4. WHEN JIB IS EXTENDED, FURLING LINE RETRACTS INTO DRUM

FORWARD →

HUNTER
 This document contains information for which HUNTER MARINE CORP. has proprietary rights.
OPTIONAL FURLING DETAILS
 DRAWING NO. 258042B
 DATE 11/29/04
 REV. NONE
 DESIGNED BY: [blank]
 CHECKED BY: [blank]
 DRAWN BY: [blank]
 ENG. [blank]

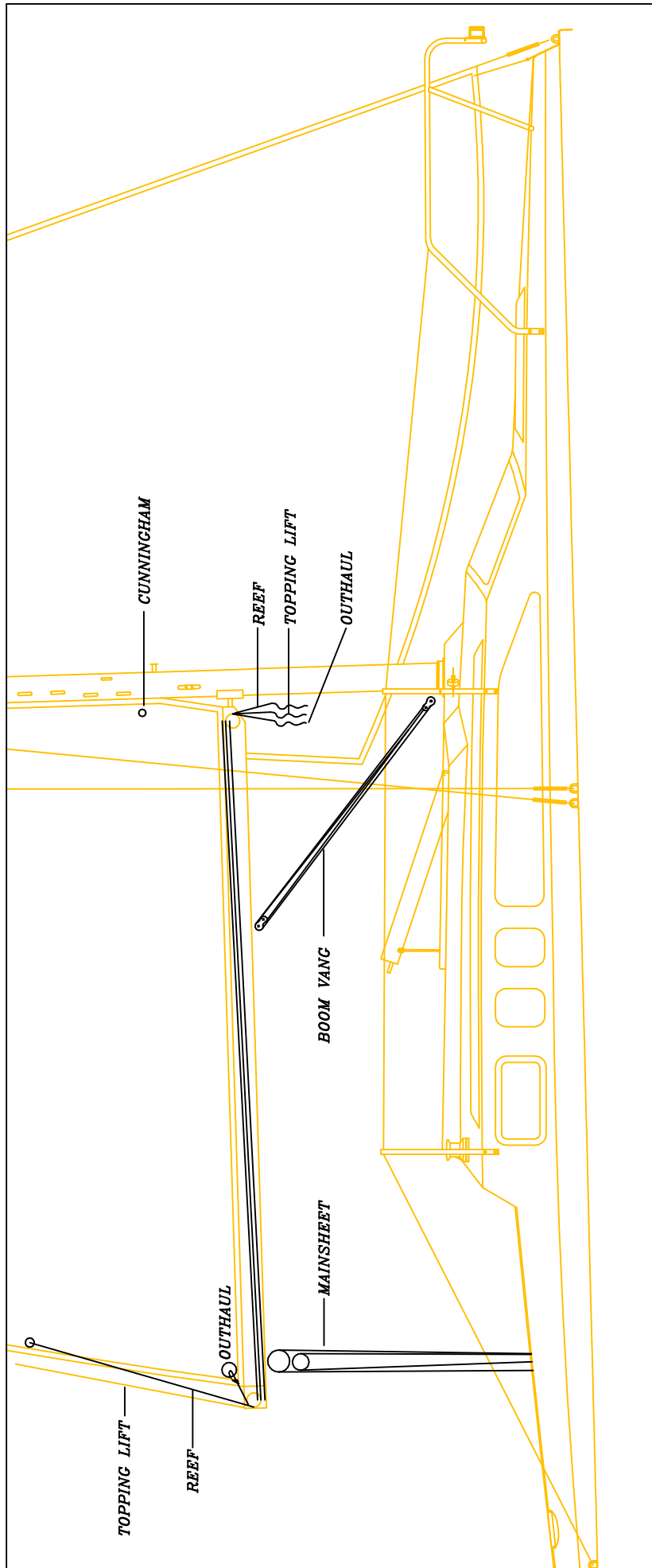

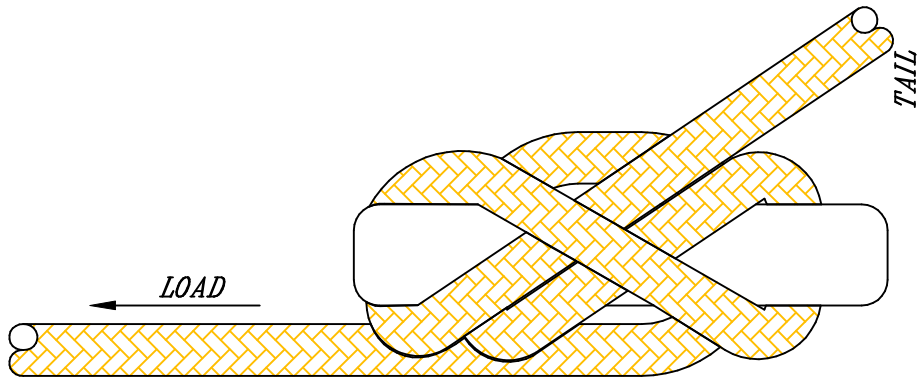

STEP 4

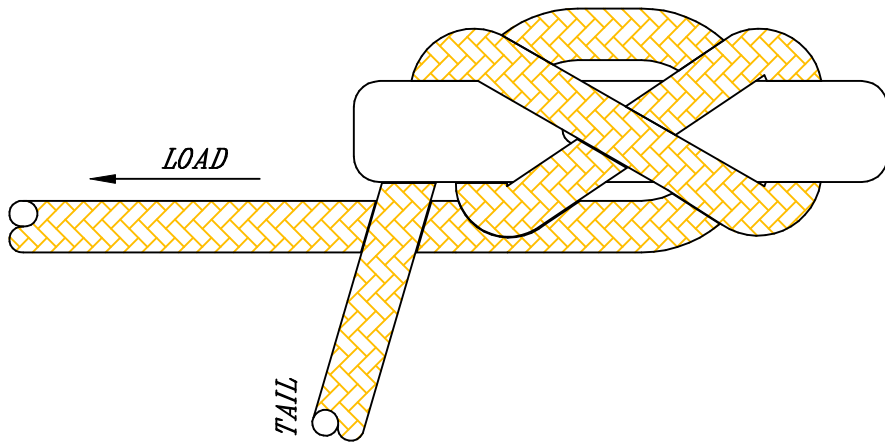

STEP 3

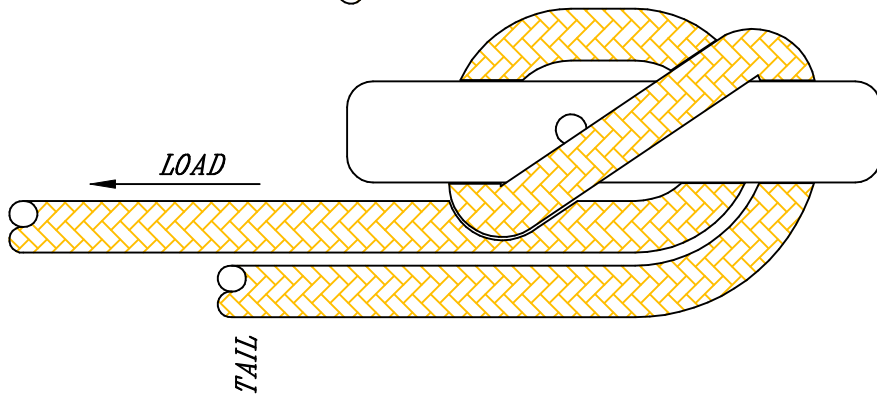

STEP 2

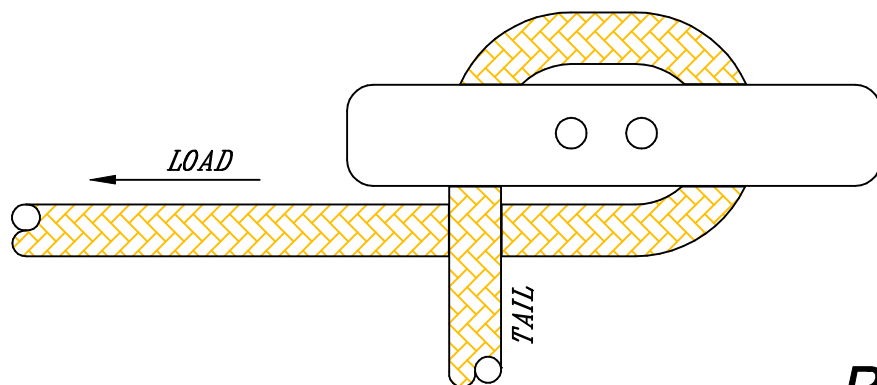

STEP 1



This document contains information for which HUNTER MARINE CORP. has proprietary rights.

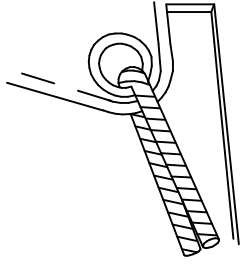

OUTHHAUL CAN BE ENDED AT CLEW, OR RUN THRU AS SHOWN HERE AND SECURE TO END OF BOOM CREATING A 2 TO 1 PURCHASE.

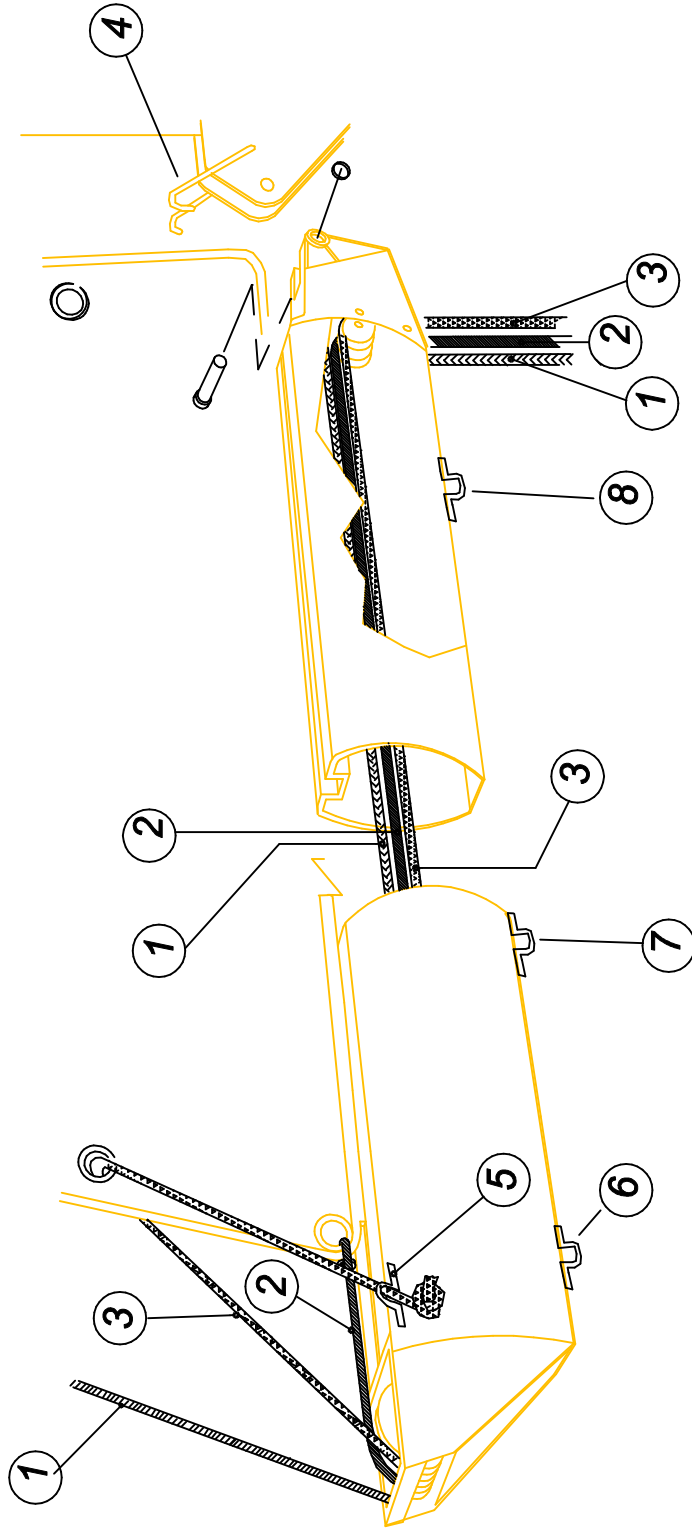

- ① BOOM TOPPING LIFT
- ② OUTHHAUL
- ③ REEF LINE
- ④ RAMSHEAD HOOKS
(FOR TACK REEF GROMMET)

- ⑤ REEF LINE BAILE
- ⑥ 2ND REEFLINE BAILE
- ⑦ MAINSHEET PURCHASE BAILE
- ⑧ VANG BAILE

MAINSHEET PURCHASE & VANG

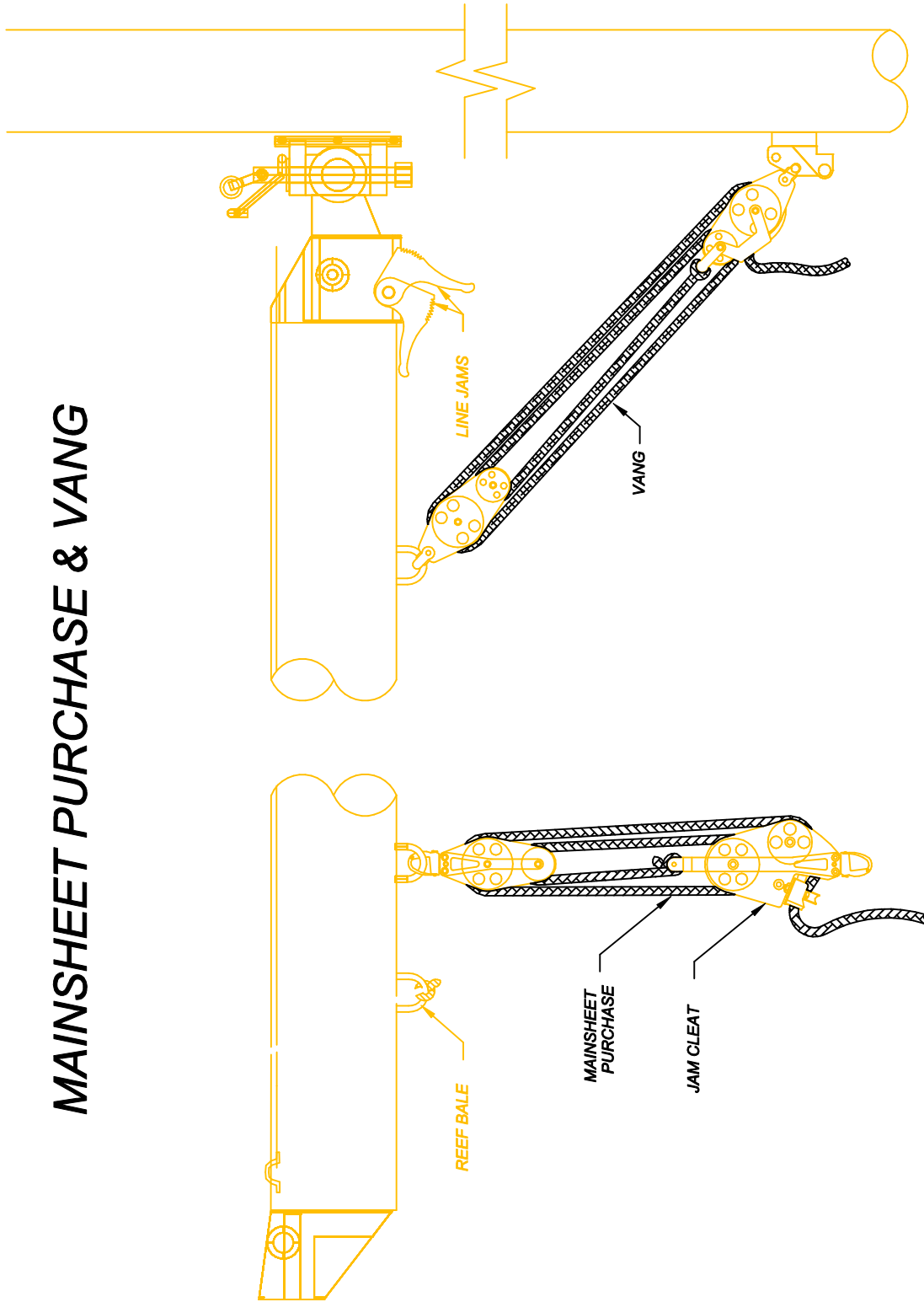

This document contains information for which HUNTER MARINE CORP. has proprietary rights.



BOOM DETAILS AND LAYOUT	
DESIGN NO.	258044B
DESIGN NO.	None
DATE	11/29/04
BY	ENG

REEFING INSTRUCTIONS

IF THE WIND STRENGTH BUILDS TO THE POINT WHERE THE BOAT HEELS EXCESSIVELY OR UNCOMFORTABLY, YOU MAY REDUCE THE SAIL AREA BY TAKING IN A REEF. REEFING IS EASIEST WHEN DONE ON A STARBOARD TACK (WHEN THE WIND IS BLOWING FROM THE STARBOARD SIDE) SINCE THE JIB SHEET IS ON THE PORT SIDE, AND THE HALYARD WINCH IS THEN FREE. HOWEVER, REEFING CAN BE DONE ON EITHER TACK.

1. FEATHER THE BOAT INTO THE WIND SLIGHTLY TO REDUCE THE HEEL.
2. EASE THE TENSION ON THE MAINSHEET.
3. MAKE SURE THE STARBOARD WINCH IS FREE BY EITHER PUTTING THE BOAT ON A STARBOARD TACK OR BY TAKING THE JIB SHEET AND JAMMING IT IN THE JIB SHEET JAM CLEAT BEFORE REMOVING IT FROM THE WINCH.
4. TRANSFER THE MAIN HALYARD TO THE WINCH, AND TAKE UP FULL TENSION OF THE HALYARD BETWEEN THE WINCH AND THE SHEET STOPPER. THEN UNLOCK THE MAIN HALYARD SHEET STOPPER.
5. LOWER THE MAIN HALYARD UNTIL THE FORWARD REEF CRINGLE ON THE SAIL CAN BE SECURED BY INSERTING THE REEF HOOK THRU LOCATED ON THE BOOM GOOSE NECK THROUGH THE CRINGLE.
6. RETENSION THE MAIN HALYARD UNTIL ALL THE SLACK OR WRINKLES ARE REMOVED FROM THE LUFF.
7. TIGHTEN THE REEF LINE AT THE FORWARD END OF THE BOOM BY PULLING THE LINE DOWN THROUGH THE SHEAVE AND JAM UNTIL THE AFT REEFING CRINGLE IS AGAINST THE BOOM AND THE LINE CANNOT BE TENSIONED ANY FURTHER. THE MAINSHEET AND VANG MAY HAVE TO BE LOOSENED TO BE ABLE TO ACHIEVE THE PROPER TENSION.

8. JAM THE REEF LINE AT THE GOOSENECK. RETENSION THE VANG AND MAINSHEET ACCORDINGLY. REJAM THE MAIN HALYARD AND TRANSFER THE JIB SHEET BACK TO THE WINCH IF NECESSARY.

9. IF THE WIND CONTINUES TO INCREASE, YOU MAY DROP THE JIB COMPLETELY AND LASH IT TO THE DECK USING A SAIL TIE. THIS WILL ALLOW YOU TO SAIL ON A REEFED MAIN ALONE. IN SOME CASES, YOU MAY FIND IT MORE EFFECTIVE TO DROP THE JIB FIRST, INSTEAD OF / BEFORE YOU TAKE IN A REEF. IT MAY ALSO BE EASIER TO TAKE IN A REEF BY TEMPORARILY LOWERING THE JIB DURING THE REEFING PROCESS.

SHAKING OUT A REEF

1. TRANSFER MAIN HALYARD TO THE WINCH AS EXPLAINED ABOVE.
2. EASE THE MAIN HALYARD DOWN ENOUGH TO REMOVE THE FORWARD REEF CRINGLE FROM THE REEF HOOK ON THE BOOM GOOSENECK.
3. UNJAM THE REEF LINE AT THE FORWARD END OF THE BOOM.
4. RAISE MAIN HALYARD USING THE WINCH. WHILE DOING SO, ENSURE THE REEFING LINE CONTINUES TO RUN THROUGH THE SAIL REEF CRINGLE AND THE FORWARD BOOM JAM.
5. TENSION THE MAIN HALYARD AND REJAM
6. ADJUST THE SHEET AND VANG AS NECESSARY.

RUNNING RIGGING SPECIFICATIONS

OPT/STD	ITEM	QUANTITY	LINE SIZE	LINE TYPE	COLOR	END 1	LENGTH	END 2
1	STD MAIN HAL YARD	1	5/16" (8mm)	XLS	BLUE	BARE	22.9 m 75 ft	BARE
2	STD JIB HAL YARD	1	5/16" (8mm)	LS	RED	BARE	22.25 m 73 ft	BARE
3	STD MAINSHEET	1	3/8" (9.5mm)	LS	BLUE FLECK	SMALL EYE	17.0 m 56 ft	BARE
4	STD REEFING LINE	1	5/16" (8mm)	TRACER	GREEN FLECK	BARE	11.3 m 37 ft	BARE
5	STD JIB SHEET	2	3/8" (9.5mm)	LS	RED FLECK	BARE	9.75 m 32 ft	BARE
6	OPT SPINN. SHEET	2	3/8" (9.5mm)	LS	BLACK FLECK	BARE	14.6 m 48 ft	BARE
7	OPT SPINNAKER HAL YARD	1	3/8" (9.5mm)	XLS	BLACK	BARE	22.25 m 73 ft	BARE
8	STD VANG	1	5/16" (8mm)	LS	WHITE	SMALL EYE	5.9 m 19 ft	BARE
9	STD CENTERBOARD LINE 1	1	3/8" (9.5mm)	XLS	WHITE	EYE	2.2 m 7.25 ft	BARE
10	STD CENTERBOARD LINE 2	1	5/16" (8mm)	LS	WHITE	EYE	0.9 m 3 ft	BARE
11	STD CENTERBOARD LINE 3	1	5/16" (8mm)	LS	WHITE	EYE	2.4 m 8 ft	BARE
12	STD TOPPING LIFT	1	1/8" PVC		WHITE		7.6 m 25 ft	BARE

STANDING RIGGING SPECIFICATIONS

OPT/STD	ITEM	QUANTITY	WIRE SIZE	UPPER END	LENGTH	LOWER END
1 STD	FORESTAY	1	5/32" (4mm) 1x19	T-BALL	8.46m 27' 9"	TURNBUCKLEw/JAW TOGGLE
2 STD	D1	2	5/32" (4mm) 1x19	T-BALL	4.617m 15' 1 1/2"	TURNBUCKLEw/JAW TOGGLE
3 STD	V1	2	5/32" (4mm) 1x19	TOGGLE FORK	4.7m 15' 5"	TURNBUCKLEw/JAW TOGGLE
4 STD	D2	2	5/32" (4mm) 1x19	FORK	3.55m 11' 8"	EYE
5 STD	RD1	2	5/32" (4mm) 1x19	EYE	2.83m 9' 4"	TURNBUCKLEw/JAW TOGGLE

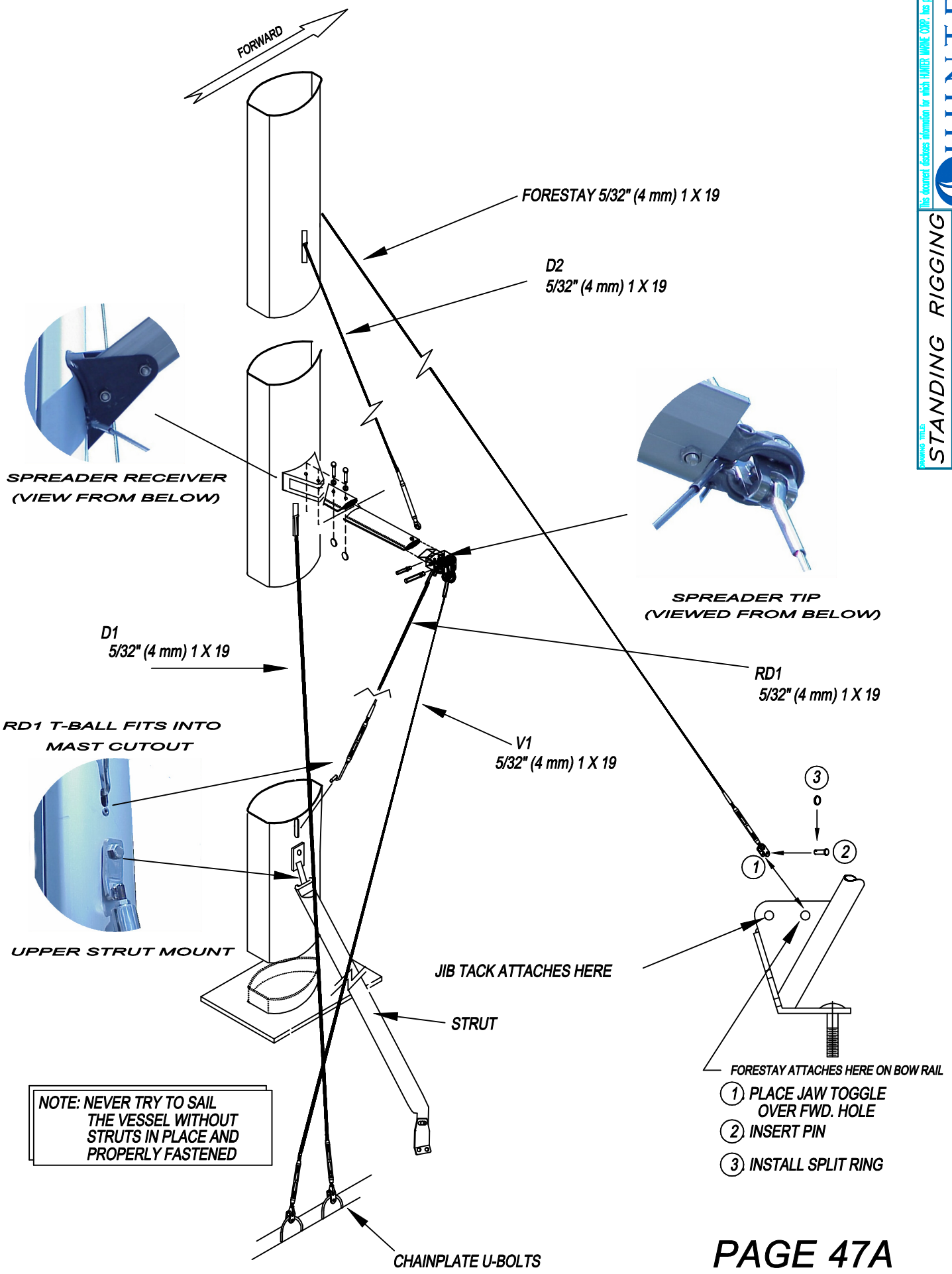

SUPPLIED

- ① 3/8" (9.5 mm) S.S. THREADED ROD
- ② 3/8" (9.5 mm) LOCK NUT
- ③ 3/8" (9.5 mm) S.S. FLAT WASHER
- ④ UPPER STRUT BRACKET
- ⑤ 3/8" (9.5mm) NYLON WASHER
- ⑥ CUTOUT FOR RD1 T-BALL
- ⑦ COMPRESSION SLEEVE

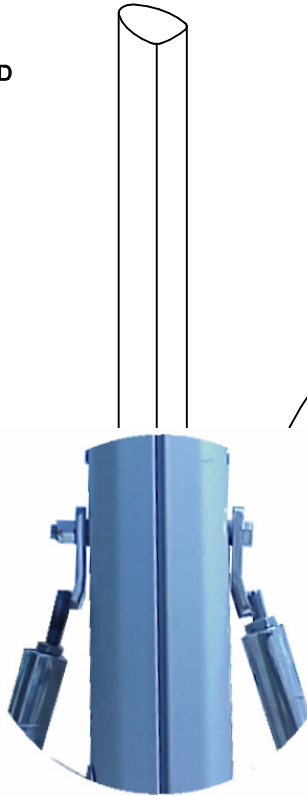

UPPER STRUT ASSEMBLY

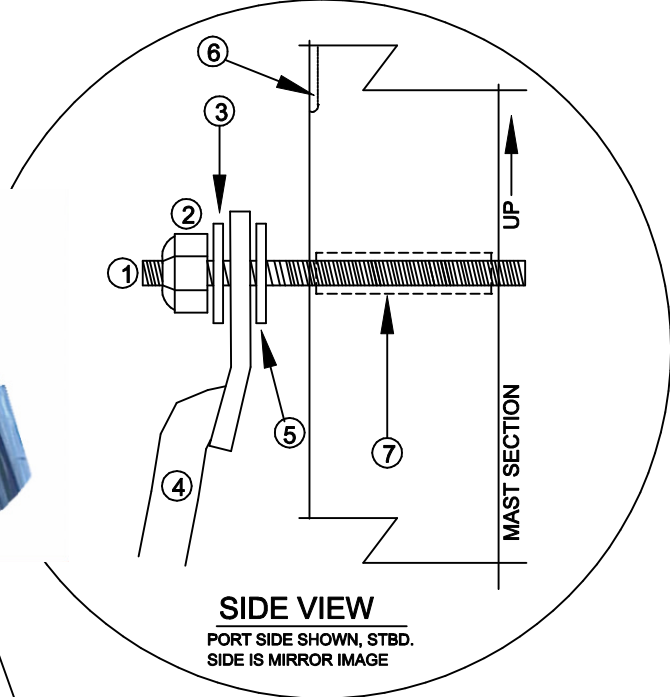

SIDE VIEW
PORT SIDE SHOWN, STBD.
SIDE IS MIRROR IMAGE

LOWER STRUT ASSEMBLY

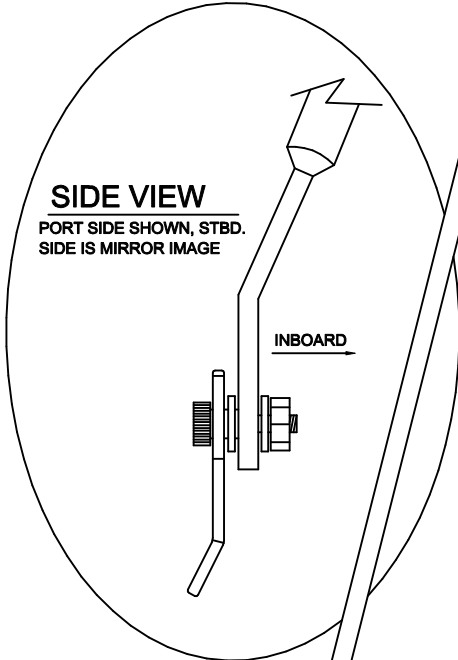

SIDE VIEW
PORT SIDE SHOWN, STBD.
SIDE IS MIRROR IMAGE

ATTENTION:
NEVER TRY TO SAIL
THE VESSEL WITHOUT
STRUTS IN PLACE AND
PROPERLY FASTENED.
SOME PLAY IS DESIRABLE,
THEREFORE DO NOT OVER-
TIGHTEN THE LOWER
STRUT BRACKET.

STRUT MOUNTING PLATES

NOTE: STRUTS MOUNT TO INBOARD
SIDE OF STRUT MTG. PLATE

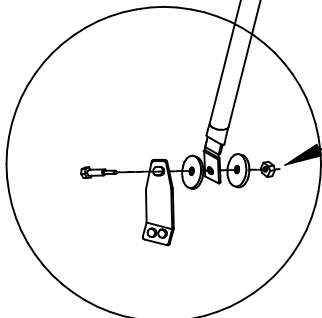

STRUT
BRACKET ASSEMBLY

THESE FASTENERS
HUNTER SUPPLIED
3/8" SHOULDER BOLTS F/W & LOCK NUTS
(9.5 mm X 25.4 mm)
PORT SIDE SHOWN-
STBD. SIDE, MIRROR IMAGE

This document contains information for which HUNTER MARINE CORP. has proprietary rights.



STRUT ASSEMBLY	
DESIGN NO. 258047B	REVISION NO. None
DRAWN BY: ENG	DATE: 11/29/04

- Ⓐ UPPER DIAGONAL (D2)
- Ⓑ VERTICAL (V1)
- Ⓒ REV. DIAG. (RD1) MARINE EYE
- Ⓓ LOWER DIAG. (D1)
- Ⓔ SPREADER TIP CASTING (INSERTED INTO SPREADER END)
- Ⓕ SPREADER TIP PINS
- Ⓖ CUTOUT (RECEIVES T-BALL)
- Ⓗ T-BALL FITTING (INSERTED INTO CUTOUT)
- Ⓘ SPREADER BAR
- ⓵ SPREADER BAR BOLTS
- Ⓚ SPREADER TIP CASING BOLT

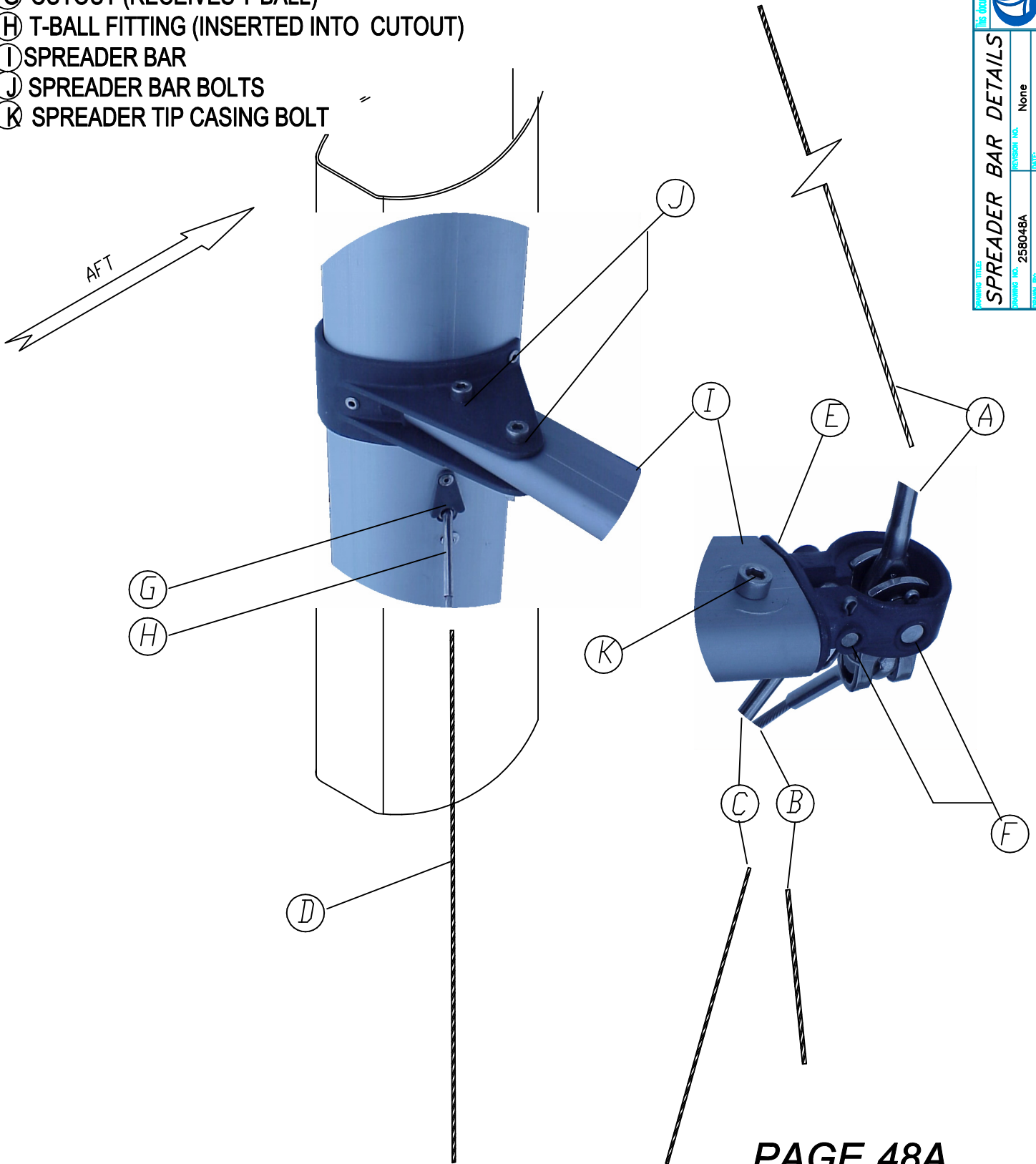

SPREADER TIP DETAILS

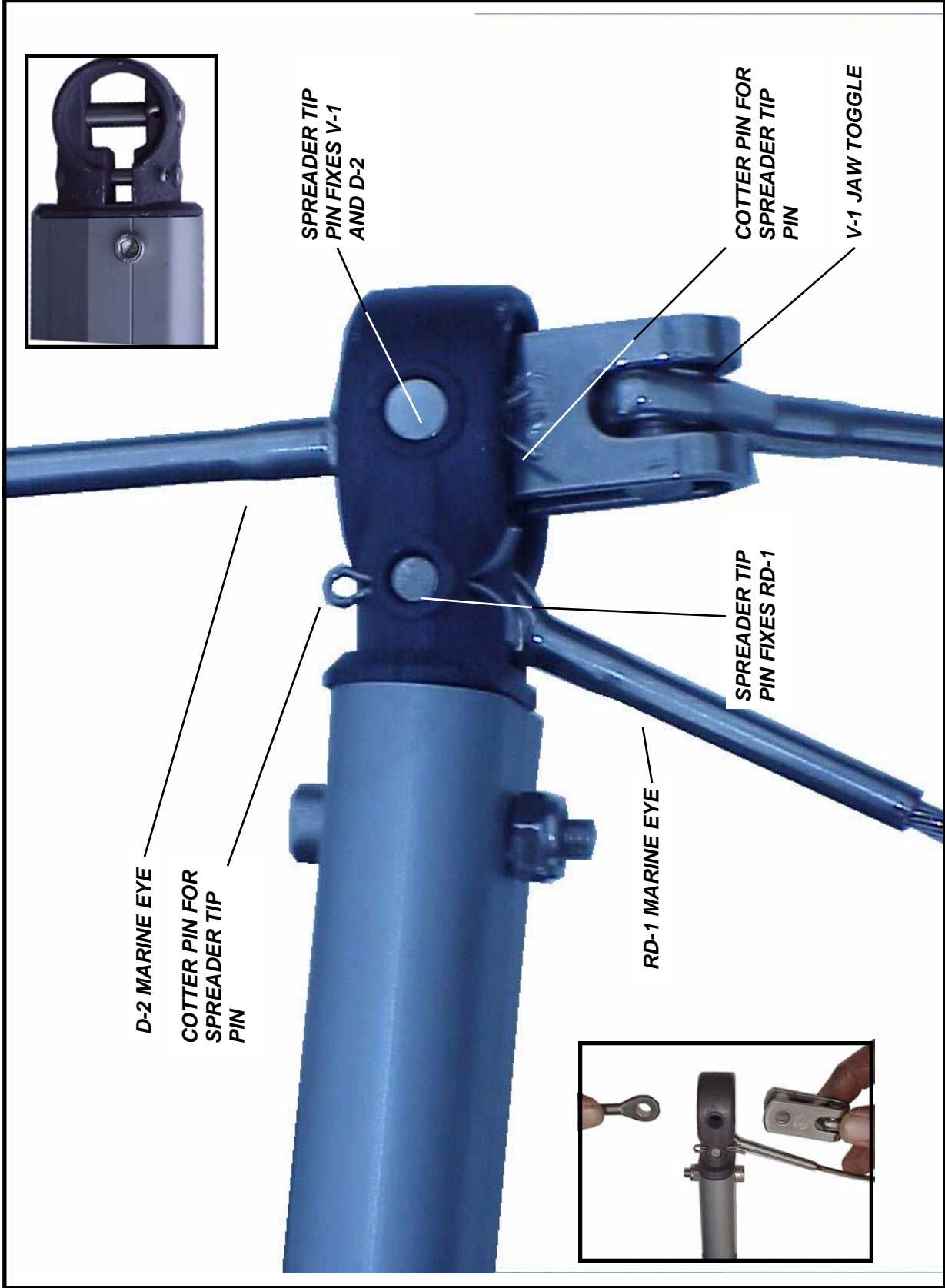

(OPTIONAL SPINNAKER BLOCK ATTACHES TO THE LOWER EYE ON THE OPTIONAL STERN SEATS)

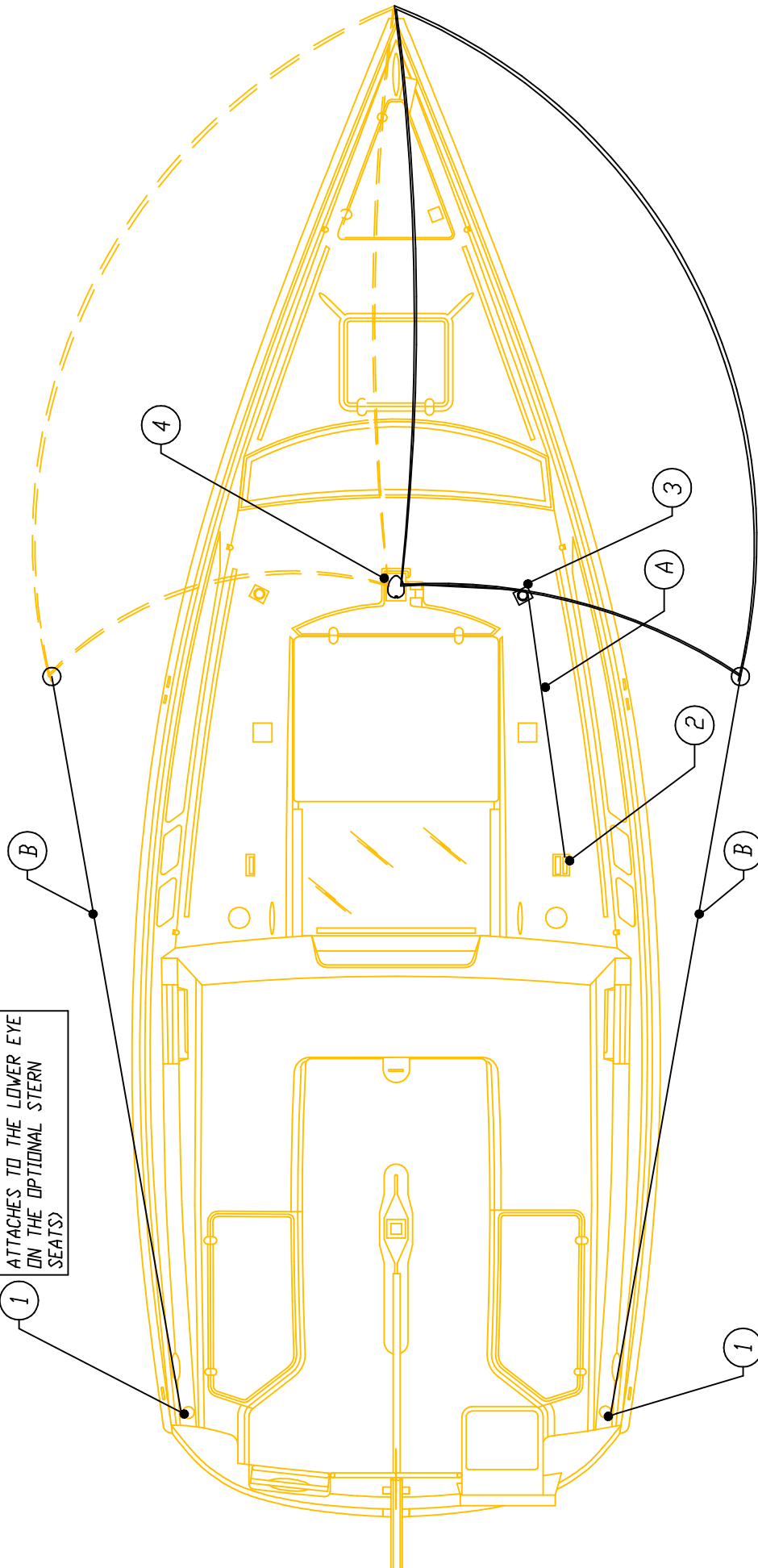

ITEMS	DECK FITTING	MANUFACTURER
1. SPINNAKER BLOCK (2) (1 PORT / 1 STBD)		HARKEN
2. LINE STOPPER (1) (ONE ADDED STBD ONLY)		EASYLOCK XA/1
3. DOUBLE STACK CHEEK BLOCK (1) (REPLACES STANDARD SINGLE CHEEK BLOCK)		HARKEN
4. SPINNAKER HALYARD MAST SHEAVE (LOCATED STBD SIDE MAST)		SCHAEFER 30-30

ITEM	LINE KIT	LINE SIZE	PART NO.
A. SPIN. HALYARD (1)		3/8" (9.5 MM) X 63' (19.3 m)	400510
B. SPIN. SHEET (2)		3/8" (9.5 MM) X 49' (14.9m)	

OPTIONAL SPINNAKER LAYOUT

DESIGN NO.	258049	REVISION NO.	None
DATE	11/29/04	SCALE	ENG

TO RAISE RUDDER, PULL RUDDER LIFT LINE AND LOCK INTO CAM CLEAT.
 NOTE: RUDDER TO BE SECURED IN THE UP POSITION WHEN TRAILERING.

TO LOWER RUDDER, PULL RUDDER LIFT LINE FROM CAM CLEAT AND LOWER. RUDDER WILL LOCK WHEN DOWN.

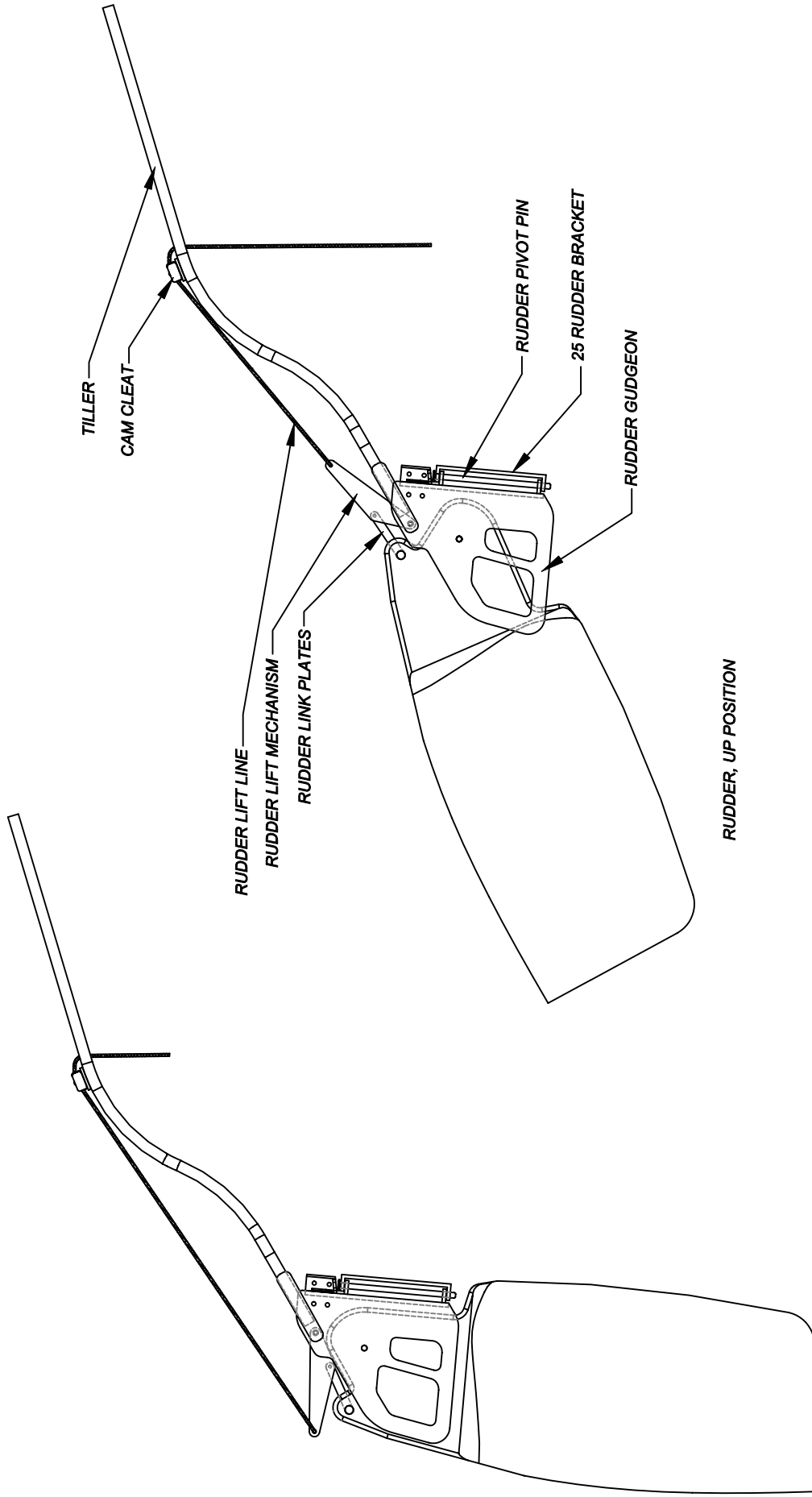

RUDDER, DOWN POSITION

RUDDER, UP POSITION

FRAMING TITLE
RUDDER DETAILS
THIS DOCUMENT CONTAINS INFORMATION FOR WHICH HUNTER MARINE CORP. HAS PROPRIETARY RIGHTS.
DRAWING NO. 258050 REVISION NO. None DATE 11/29/04
DESIGNER ENG



This Page Intentionally Left Blank

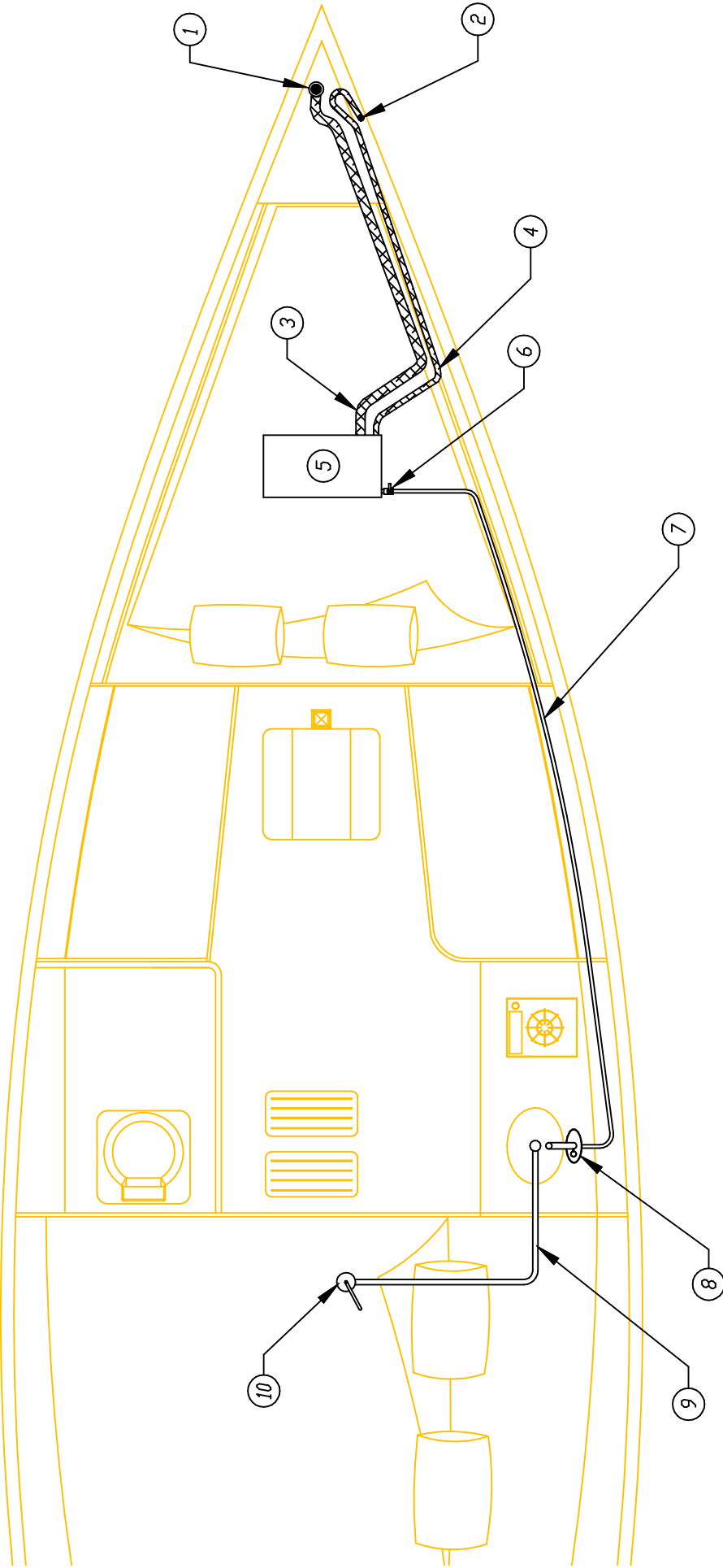

- ① H2O TANK FILL DECK FITTING, 1 1/2" (38 mm)
- ② H2O TANK VENT, HULL FITTING 3/4" (19 mm)
- ③ H2O FILL HOSE, 1 1/2" (38 mm) HOSE
- ④ H2O VENT HOSE 3/4" (19 mm) HOSE
- ⑤ H2O TANK, 10 GAL. (37.9 L)
- ⑥ TANK ON/OFF VALVE
- ⑦ H2O SUPPLY LINE, 15mm TUBING
- ⑧ GALLEY FAUCET
- ⑨ 1 1/8" DRAIN HOSE
- ⑩ 1" THRU HULL FITTING W/ BALL VALVE

BILGE PUMP PLUMBING DETAIL

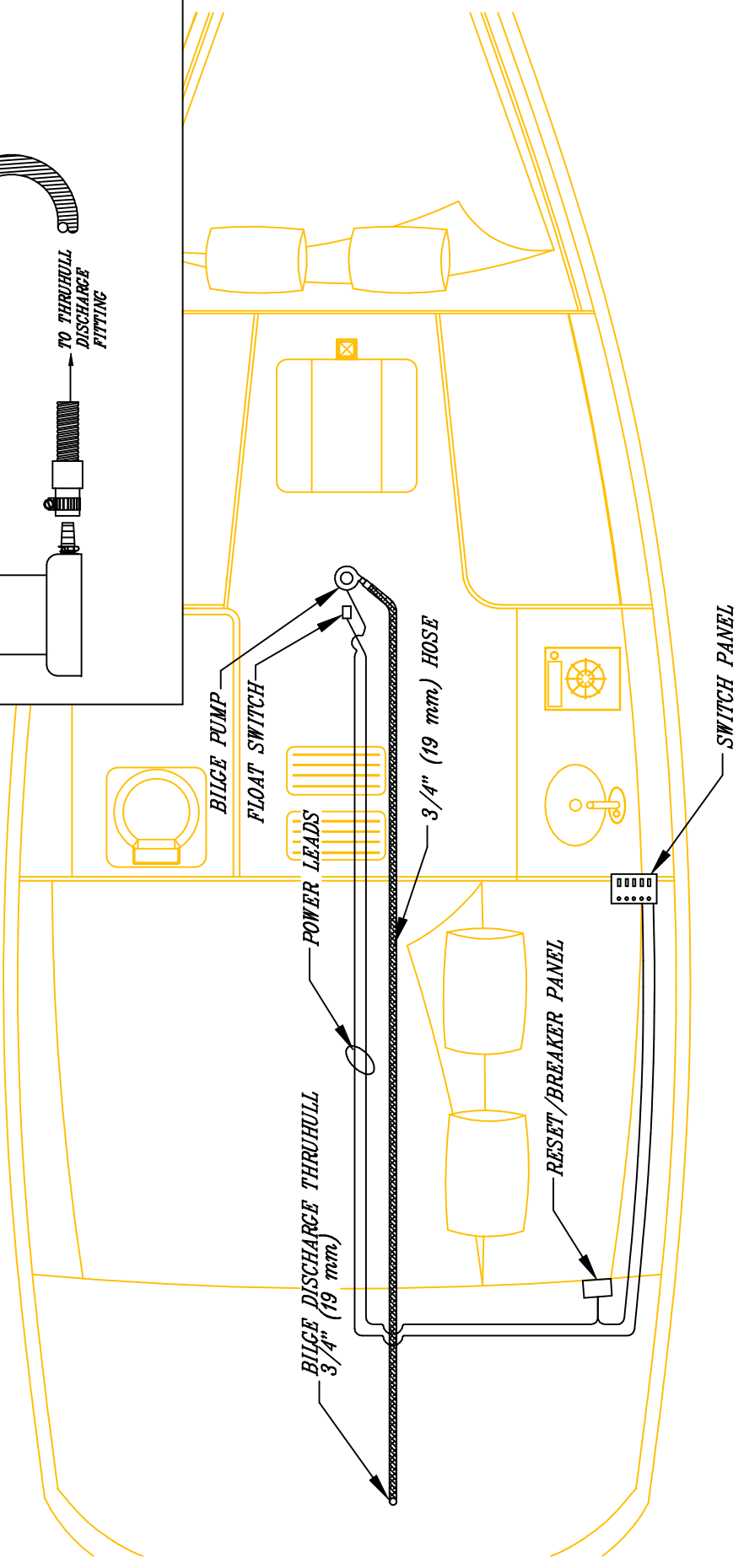
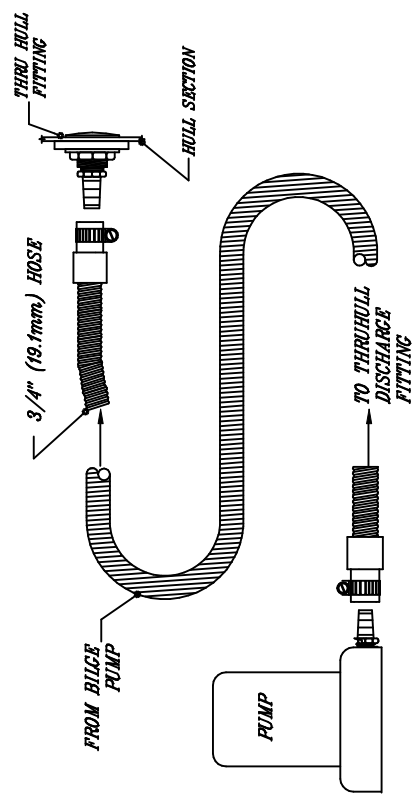

POWER FILE
BILGE PUMP LAYOUT
DESIGN NO. 258052A REVISION NO. None DATE 11/29/04
DESIGNER ENGINEER ENG



This document contains information for which HUNTER MARINE CORP. has proprietary rights.

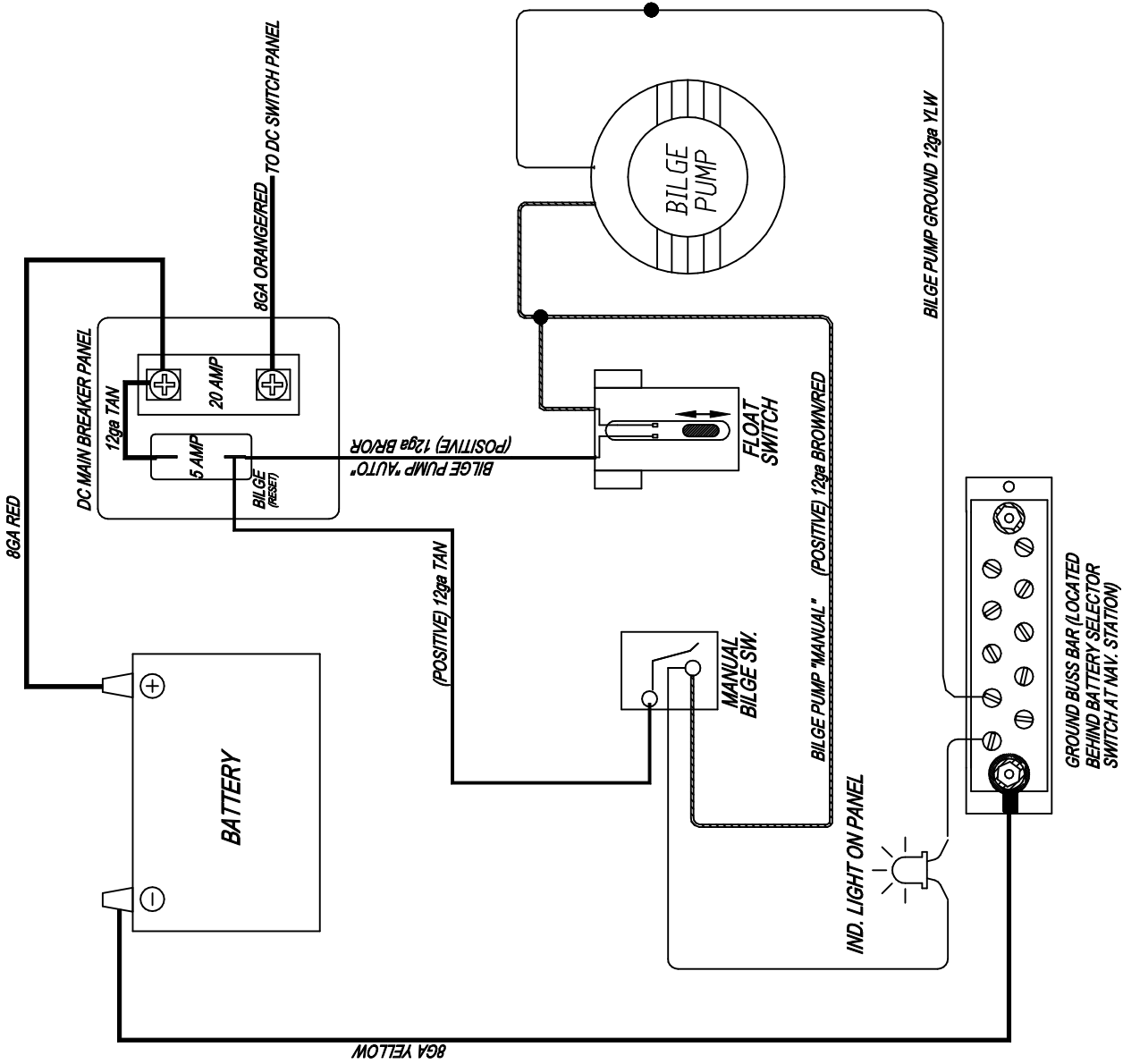

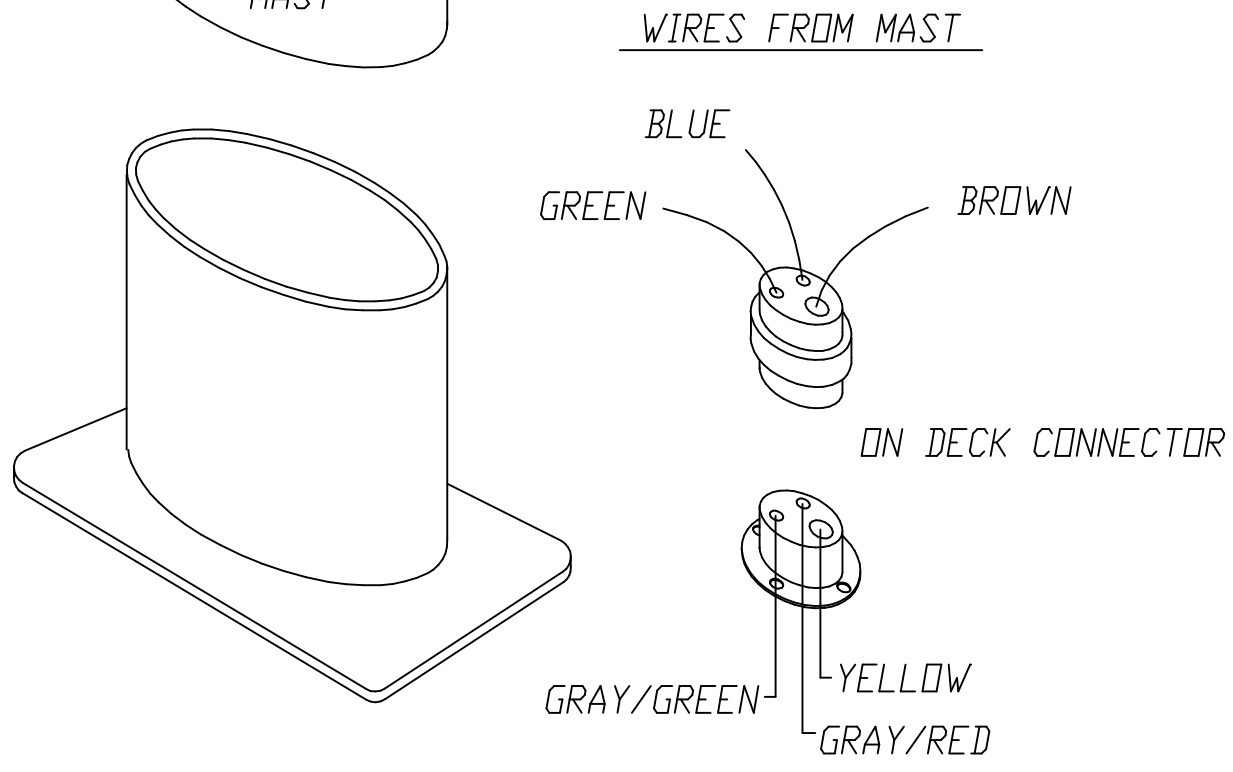
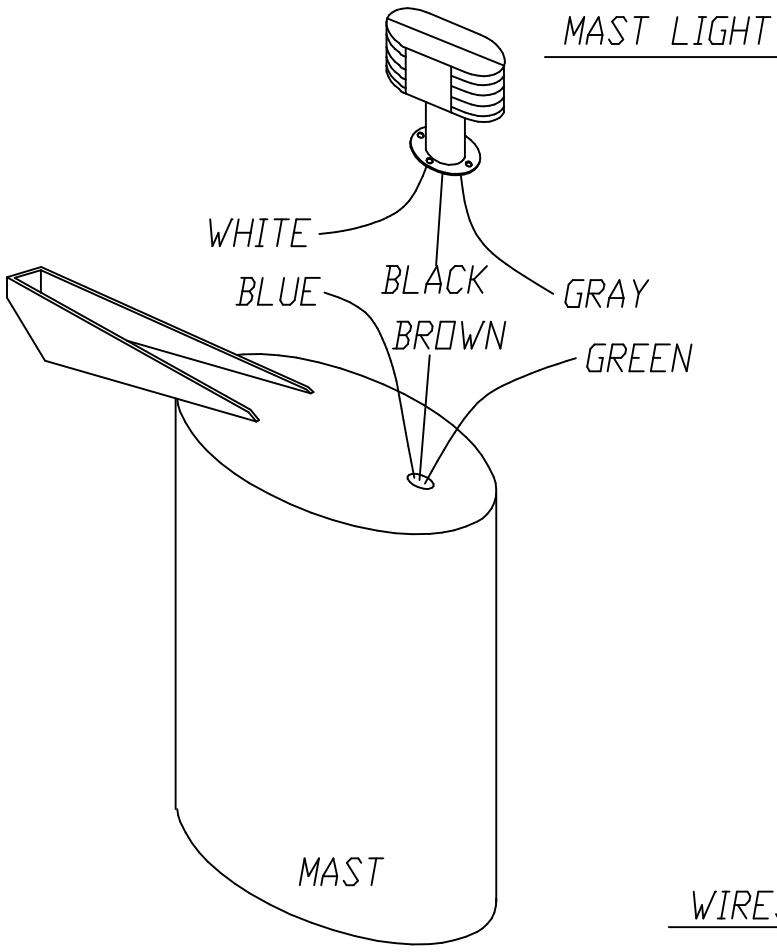

MAST WIRING DETAIL

DESIGN NO.	258053	REVISION NO.	None
DRAWN BY:	ENG	DATE	11/29/04

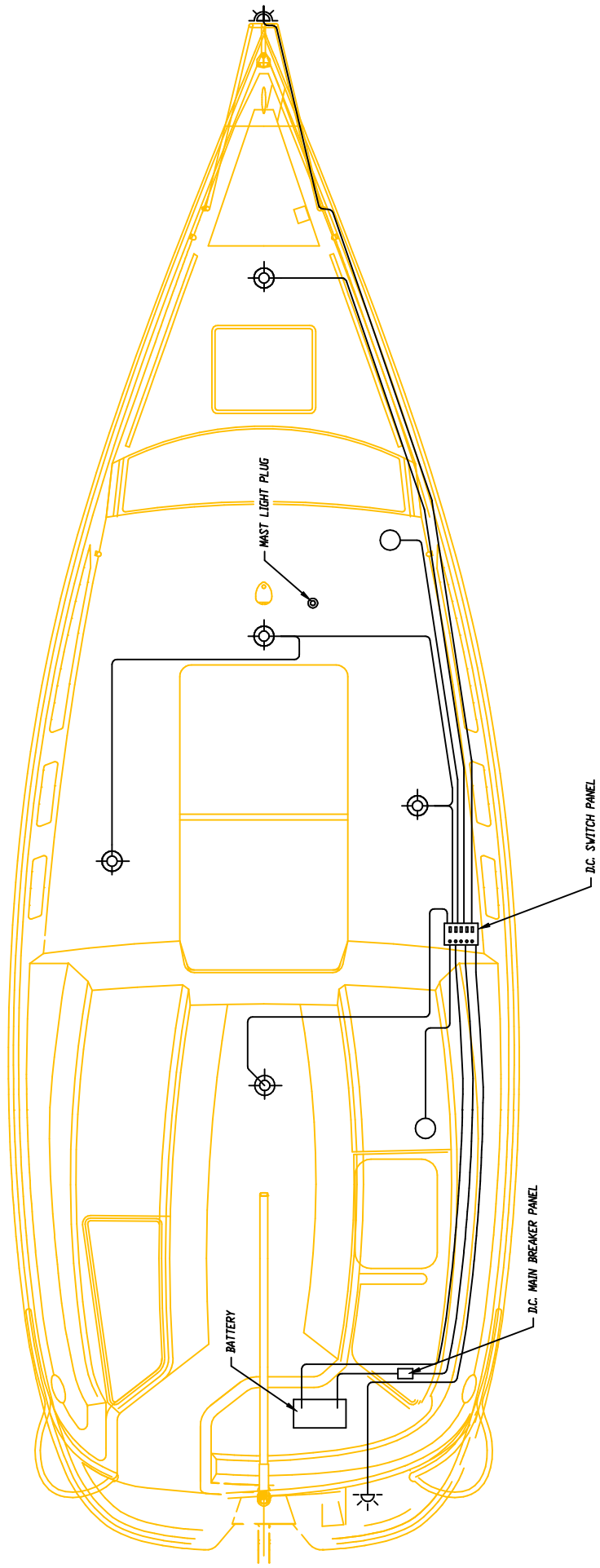

LEGEND

- ☒ BOW LIGHT
- ☒ STERN LIGHT
- ⊙ DOME LIGHTS (INTERIOR)
- C.D. ALARM

DRAWING TITLE: **12V.D.C. WIRING LAYOUT**
 DRAWING NO.: 258054A
 DESIGNER: None
 DATE: 11/29/04
 DRAWN BY: ENG

This document contains information for which HUNTER MARINE CORP. has proprietary rights.

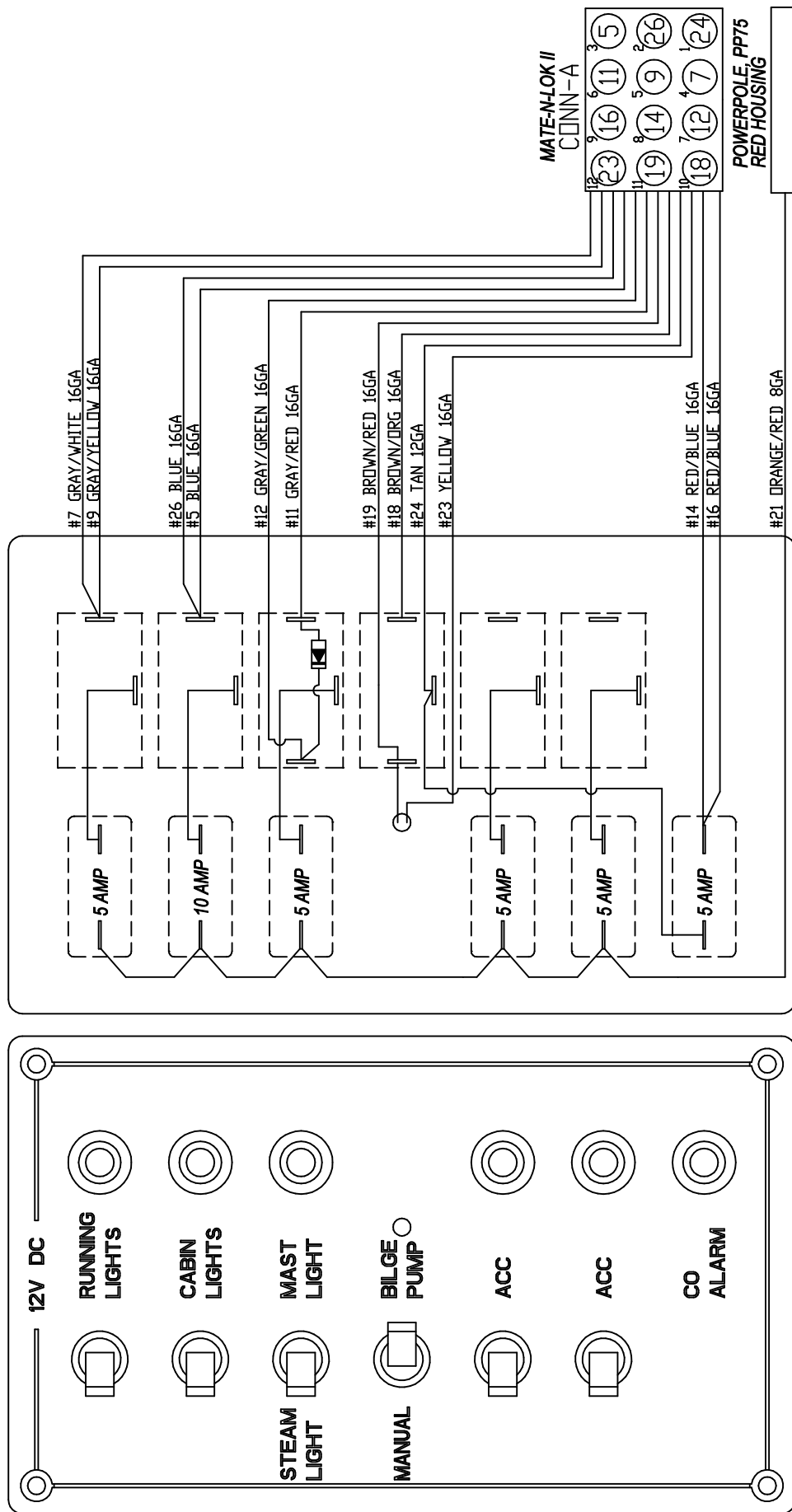

This document describes information for which HUNTER MARINE CORP. has proprietary rights.



D.C. SWITCH PANEL SCHEMATIC

REVISED NO.	258054B	REVISION NO.	None
DATE	11/29/04	DATE	11/29/04
DESIGNED BY	ENG	DATE	11/29/04

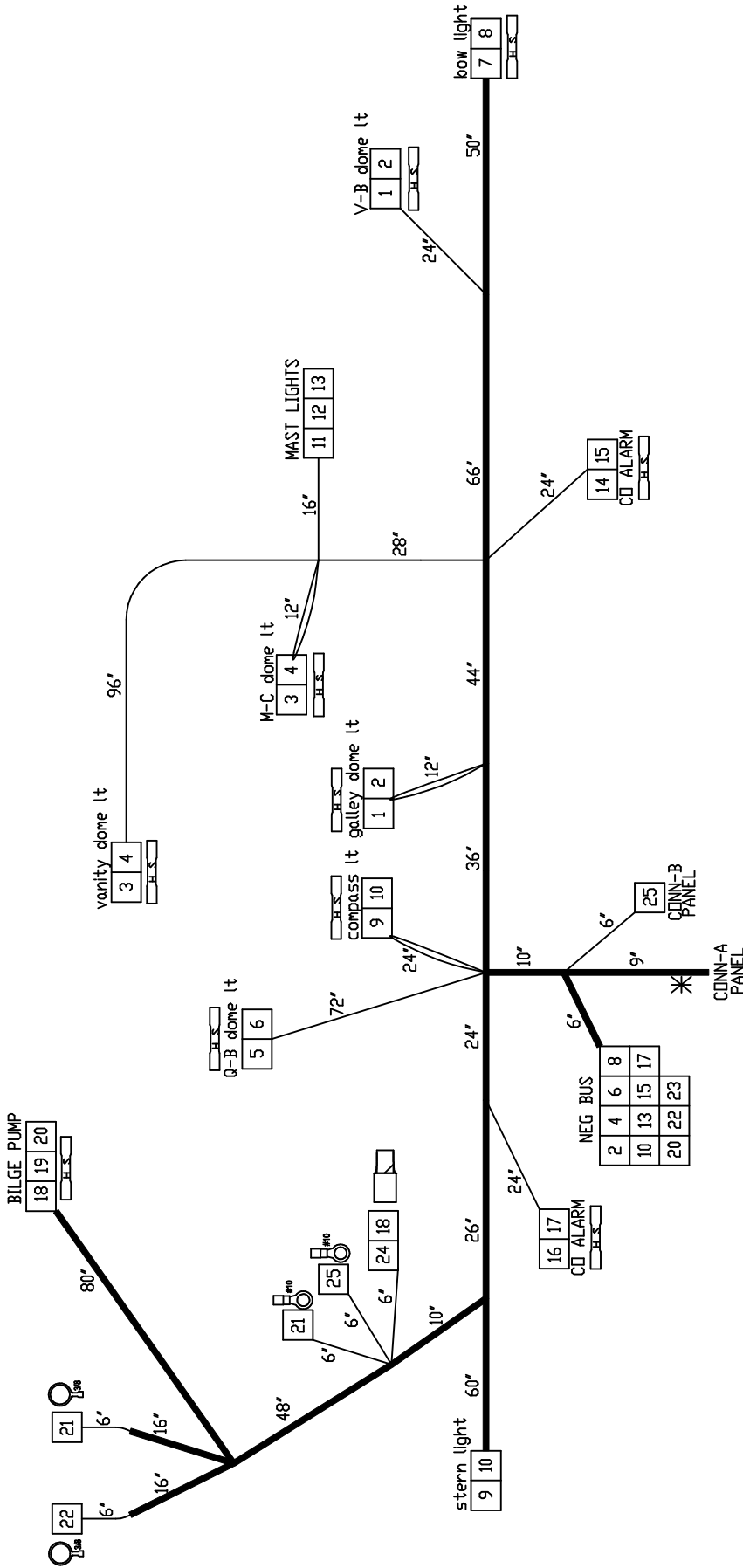

* = SPLICE #26 TO #1 AND #3 @ 3"

- = CONDUIT
- BARREL
- #10 RING
- 1/4" RING
- 5/16" RING
- 3/8 RING
- 1/4 SLIDE
- 1/4 SLIDE W/PIGGYBACK

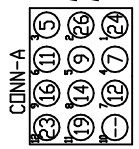

MATE-N-LOK II
MALE HOUSING W/MALE PINS

CONN-B POWERPOLE, PPT5
RED HOUSING

This document discloses information for which HUNTER MARINE CORP. has proprietary rights.

ELECTICAL HARNESS	
DRAWING NO. 258054C	REVISION NO. None
DRAWN BY: ENG	DATE: 11/29/04

① COMMODE/CONTROL

② RAW WATER PICKUP/SEACOCK 3/4" (19 mm)

③ VENTED LOOP 3/4" (19 mm)

④ WASTE SANITATION HOSE 1 1/2" (38 mm)

⑤ WASTE HOLDING TANK 13 GAL. (49.2 L.)

⑥ TANK VENT, HULL FITTING & 3/4" (19mm) SHIELDVAC HOSE

⑦ TANK PUMPOUT DECK FITTING & 1 1/2" (38 mm) SANITATION HOSE

→ = FLOW DIRECTION

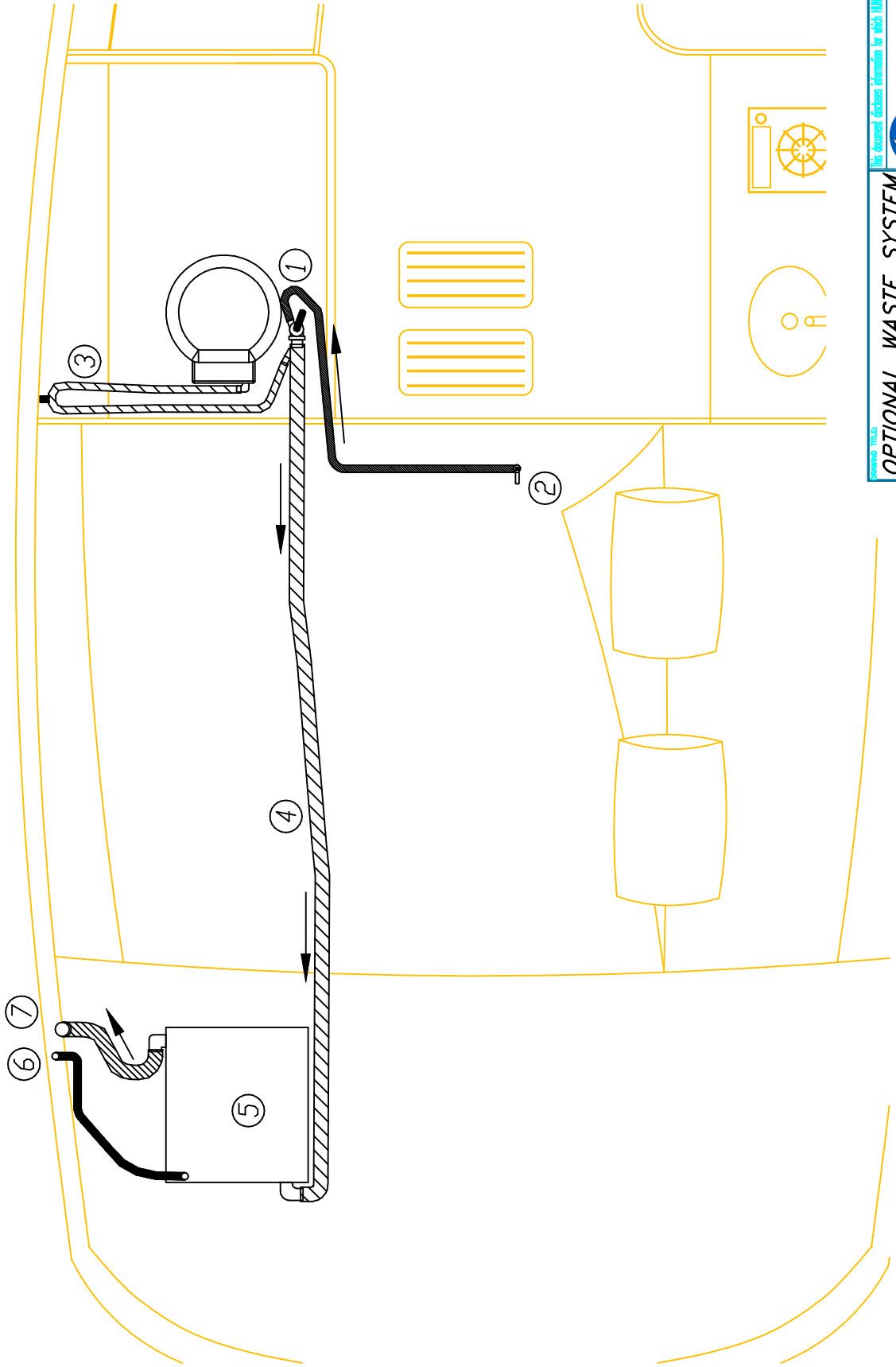

NOTE: THE FORWARD SIDE CLEATS ON THE DECK ARE CONSIDERED THE STRONG POINT. THAT SHOULD BE THE ANCHOR POINT IF THE BOAT IS TO BE LEFT UNATTENDED.

NOTE: ALWAYS SECURE ANCHOR RODE TO THE CLEAT OR LASH ANCHOR SECURE TO BOW ROLLER IN ADDITION TO THE QUICK PIN!

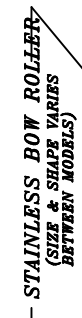
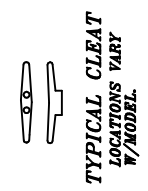
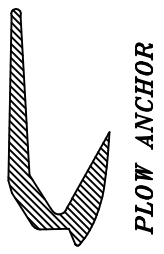
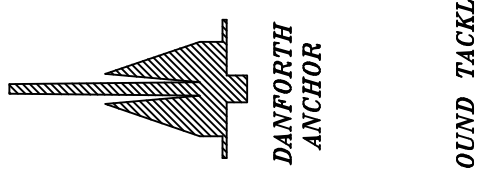

- GROUND TACKLE:**
- 1.) BOW SHACKLE(W/PIN WIRED)
● ANCHOR...FOL'D. BY...
 - 2.) SWIVEL...FOL'D. BY...
 - 3.) CHAIN(OPTION)...FOL'D. BY...
 - 4.) D-SHAPED SHACKLE(W/PIN WIRED) ● EA. 27M OF CHAIN OR ● CHAIN TO ROPE RODE.

PLAN

ELECTRIC ANCHOR WINDLASS (STANDARD OR OPTIONAL ON LARGER MODELS)

WELL: SMALLER MODELS

WELL: LARGER MODELS

ELEVATION

WATERLINE

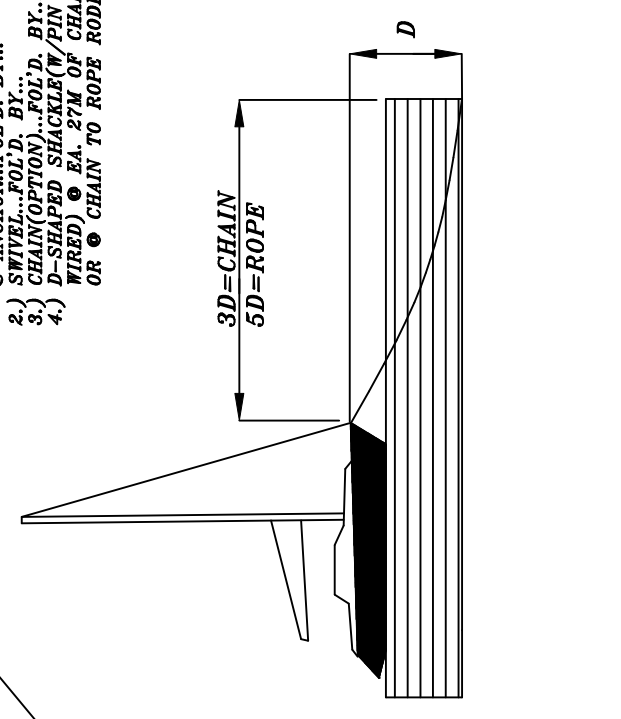

FORWARD TITLE
ANCHORING SYSTEM
DESIGN NO. 258056 REVISION NO. None DATE 11/29/04
DESIGN BY ENG



HUNTER

This document contains information for which HUNTER MARINE CORP. has proprietary rights.

This Page Intentionally Left Blank