

Hunter 20

PLUMBING DIAGRAM

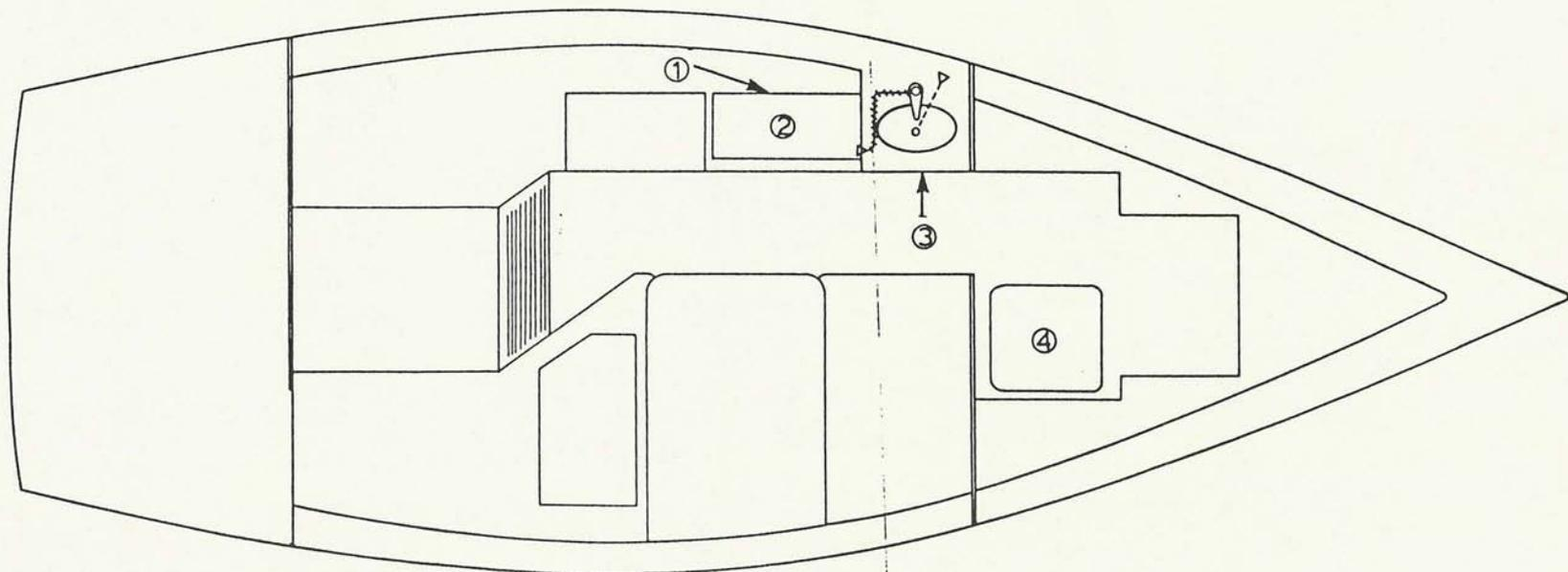

LEGEND:

- ① MOLDED WATER TANK
- ② WATER FILL PLATE W/VENT
- ③ SINK W/HAND PUMP
- ④ HEAD SANI-POTTI 944

SYMBOLS:

- 3/4" SHIELDVAC W/HOSE CUFFS
- - - - - 1-1/4" SHIELDVAC W/HOSE CUFFS
- △ THRU-HULL (PLASTIC), SIZE TO MATCH ATTACHED HOSE

HUNTER MARINE LIMITED WARRANTY

Hunter Marine warrants to the first-use purchaser for a period of twelve (12) months from the date of sale any part manufactured by Hunter to be free of defects caused by faulty workmanship or materials under normal use and service.

During this period Hunter Marine will replace any part judged to be defective by Hunter Marine free of charge at its plant or at the option of Hunter, by an authorized Hunter Marine dealer. Transportation costs are the responsibility of the first-use purchaser. The labor cost reimbursement will be based on a labor allowance schedule established by Hunter Marine and, where not applicable, on a reasonable number of hours as determined by Hunter Marine. All repairs and replacements must be approved in advance by an authorized Hunter Marine representative.

The warranty does not cover:

- (1) Paint, window glass, gel coat, upholstery damage, plastic finishes, engines, engine parts, propellers, shafts, controls, instruments and equipment not manufactured by Hunter Marine.
- (2) Boats or parts which have been altered or subjected to negligence or misuse.
- (3) Commercially used boats.

This warranty is expressly in lieu of any and all other remedies and expressed warranties. Any implied warranties, including the warranties of merchantability and fitness are limited to the duration of this limited warranty. Some states do not allow limitations on how long an implied warranty lasts, so that the above limitation may not apply to you.

Any consequential damages which may be incurred are excluded and the liability of Hunter Marine and the purchaser's remedy shall be limited to repair or replacement of any part or party judged defective by Hunter Marine. Some states do not allow the exclusion or limitation of incidental or consequential damages, so the above limitation exclusion may apply to you.

The purchaser acknowledges that no other representations were made to him with respect to the quality and function of the boat.

This warranty gives you specific legal rights and you may have other rights which vary from state to state.

This warranty shall not be effective unless the Hunter Marine warranty card and pre-delivery service record are completed and returned to Hunter Marine within ten (10) days after the date of sale to the first-use purchaser.

PRE-DEPARTURE CHECK-LIST

- Check bilge for excess water.
- Check weather conditions and tides.
- Check food supply.
- Foul weather gear.
- Linen, sleeping bags.
- Fuel.
- Water.
- Sunscreens and sunglasses.
- Tools.
- Docking and anchor gear.
- Check radio operations.
- Navigation charts and instruments.
- Float plans to a friend or Coast Guard. *(See next page.)*
- Fuel for stove.
- Cooking and eating utensils.
- Check battery water level.
- Oil level, tight V-belts.
- Check for loose electrical connections in engine room.
- Secure tools or any loose equipment in engine room so as not to get fouled in engine.
- AC systems off; electrical cord stowed.
- Doors and drawers secured.
- Check steering lock to lock.
- Check mast for rigging irregularities and tightness.
- Halyards and sheets are clear and ready to run.
- No lines or other obstructions near the propeller or bow.
- Anchor ready to run.
- Check lifelines for tightness.
- Turn on fuel and water lines.
- Stow all loose gear.
- Open engine cooling water intake thru-hull valve.

FLOAT PLAN

1. Name of person reporting and telephone number:

2. Description of boat:

NAME _____ TYPE _____

MAKE _____ LENGTH _____ REGISTRATION # _____

HULL COLOR _____ STRIPE COLOR _____ DECK COLOR _____

OTHER DISTINGUISHING MARKS _____

3. Persons aboard:

NUMBER _____

NAME _____ AGE _____ PHONE # _____

ADDRESS _____

NAME _____ AGE _____ PHONE # _____

ADDRESS _____

NAME _____ AGE _____ PHONE # _____

ADDRESS _____

4. Engine:

TYPE _____ H.P. _____ FUEL CAPACITY _____

5. Safety equipment:

PFDs Flares Mirror Flashlight
 Food Water EPIRB Raft/Dinghy

6. Radio:

TYPE _____ FREQUENCIES _____

7. Trip expectations:

DEPARTING AT (APPROX. TIME) _____ ON (DATE) _____ FROM (LOCATION) _____

GOING TO (LOCATION) _____ RETURNING (DATE) _____ IN NO EVENT LATER THAN (TIME & DATE) _____

8. Automobile:

LICENSE # _____ STATE _____

MAKE _____ COLOR _____ PARKED AT _____

9. If not returned by _____, call the Coast Guard or:

at: _____

CLOSING UP YOUR BOAT AFTER SAILING

When leaving your Hunter or Legend at the dock for more than a short time, it is a good idea to review the following check list to make sure everything is in order. This will help protect the various parts of your boat and add considerably to their attractiveness and usable life.

- Fold and bag headsails and stow below.
- Furl mainsail and cover, or remove and also bag.
- Remove and stow all portable deck hardware such as snatch blocks, winch handles, etc.
- Secure the boom to the topping lift and set it firmly amidships with the mainsheet purchase. (It is also a good idea to rig a line from the steering wheel or tiller to a convenient cleat to keep the rudder from swinging back and forth with the motion of the water.)
- Attach the shackle ends of all halyards to convenient fittings and take up slack.
- Cleat and coil halyard tails and permanent sheets, hanging them off the deck to promote drying.
- Coil and stow all other lines.
- Cover the winches and steering pedestal when leaving the boat for several days or more.
- Close all fuel lines and gate valves.
- Turn off the electrical system.
- Pump the bilge.
- Check air vents, secure ports and hatches, and swab the deck, particularly if you have operated on saltwater.
- Make a final check of mooring lines, chafing gear, fenders, etc.

FOR SAFE BOATING

BE PREPARED

Take a safe boating course from the Coast Guard. You can call 800-336-BOAT for information on courses in your area.

Carry all safety equipment required by federal and state law. Federal requirements are discussed in "Federal Requirements for Recreational Boats" which can be acquired from U.S. Coast Guard Office of Boating, Public, and Consumer Affairs, Washington, D.C. 20593. State requirements will come from your local State Boating Administration. The Coast Guard also recommends a first-aid kit, a pump or bailer, a transistor or weather radio, extra fuel, a paddle, anchor and line, and extra drinking water; also, if not a requirement, flares.

Get a Coast Guard Auxiliary Courtesy Examination. This is a free, confidential safety inspection. Call your local Coast Guard Auxiliary for details.

Be familiar with the use of distress signals and PFDs.

AVOID FIRES

Handle fuels carefully,

Read the engine owner's manual for proper fuel-system maintenance and inspect your engine's fuel system periodically.

Heed fire extinguisher regulations and keep them in good condition.

While refueling:

- a. Fill the portable tanks on the dock.
- b. Tie the boat securely.
- c. Extinguish cigarettes and all flames on the boat. Turn off all engines and electrical equipment.
- d. Keep the hose nozzle in contact with the fuel can or fill.
- e. Wipe up all fuel spillage.
- f. Ventilate the engine and fuel compartment.
- g. Check boat for fumes.

BEFORE GETTING UNDERWAY

Leave a float plan. (See example on page I-5.)

Perform pre-departure check list. (See check list on page I-4.)

Check the weather: do not venture out if the weather is threatening.

WHILE UNDERWAY

PFDs should be worn by children and non-swimmers at all times. *Everyone should wear them if conditions become hazardous.*

Do not operate a boat if intoxicated, fatigued or stressed. These human factors cause 50 percent of all boating accidents.

Keep a good lookout. This is especially true of sailboats. Keep a watch to leeward under the headsail. Keep away from swimmers, divers and skiers.

Obey state and federal laws. Know your local laws and "rules of the road."

Respect bad weather: try to get to shore if the weather turns bad. Get and carry a radio with a NOAA "weather band" on FM 162.40-162.55MHZ.

FOR SAFE BOATING *(Continued)*

IF TROUBLE OCCURS

Radio for help. Use the emergency VHF channel (i.e., 156.8MHZ).

Put on PFDs immediately.

Stay with the boat. In cold water, huddle together to prevent hypothermia.

FLOAT PLAN

Make copies of the example on page I-5 and use one before each trip. Fill it out and leave it with a reliable person who will notify the Coast Guard or other rescue organization if you fail to return on time. **Do not forget to cancel the float plan upon your return.**

Hunter 20

SPECIFICATIONS

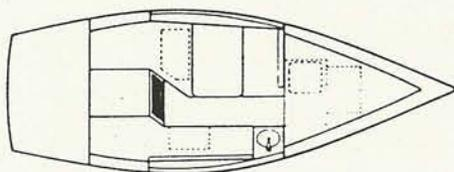
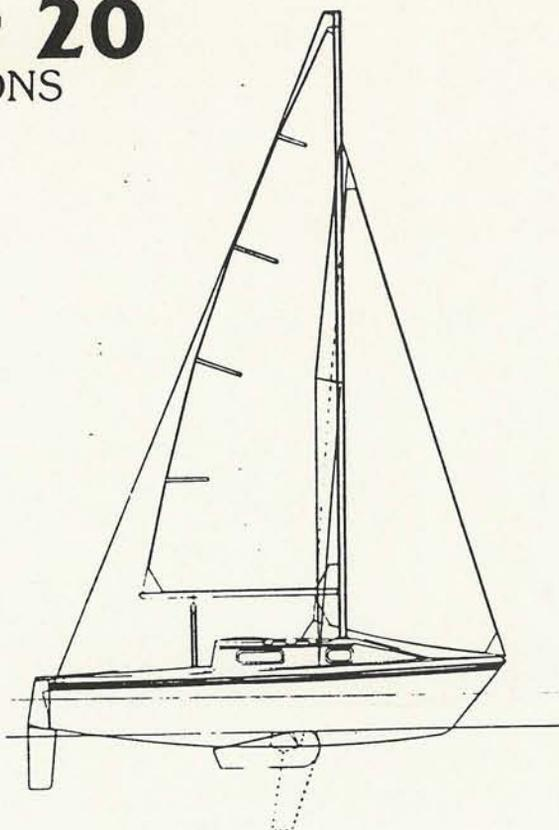

L.O.A.	19'8"	5.99m.
L.W.L.	15'6"	4.72m.
Beam	7'6"	2.29m.
Draft: Board up	1'3"	.33m.
Board down	4'0"	1.22m.
Displacement	1,700 lbs.	771.8 kg.
Ballast	400 lbs	181.6 kg.
Mast height	25'9"	7.85m.
from waterline	29'6"	8.99m.
Sail area	170 sq.ft.	15.79 sq.m.
E (Mainsail foot)	8'4"	2.54m.
J (Foretriangle base)	6'9"	2.06m.
P (Mainsail luff)	23'6"	7.16m.
I (Foretriangle ht)	21'0"	6.40m.

Hunter 20'

CENTER BOARD MECHANISM

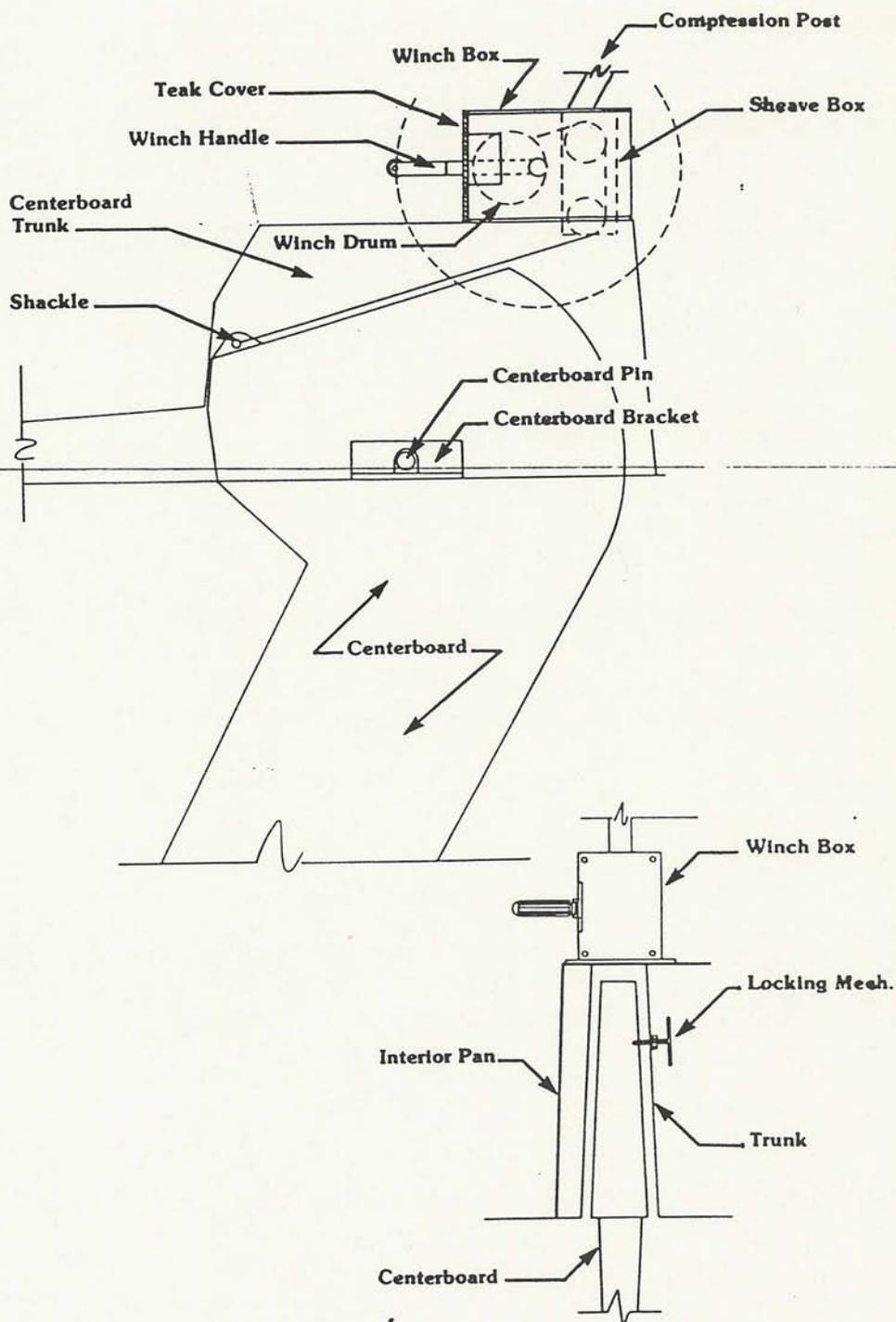

RUNNING RIGGING

1	MAINSHEET	3/8"	30'
1	JIBSHEET	3/8"	60'
1	OUTHAUL	1/4"	6'
1	TOPPING LIFT	1/4"	7'

STANDING RIGGING

1	HEADSTAY	1/8"	1x19	23' 1"
1	BACKSTAY	1/8"	1x19	29' 2"
2	UPPERS	1/8"	1x19	22' 1"
2	LOWERS	1/8"	1x19	11' 10"

HUNTER

RIGGING LENGTHS GEN2614A

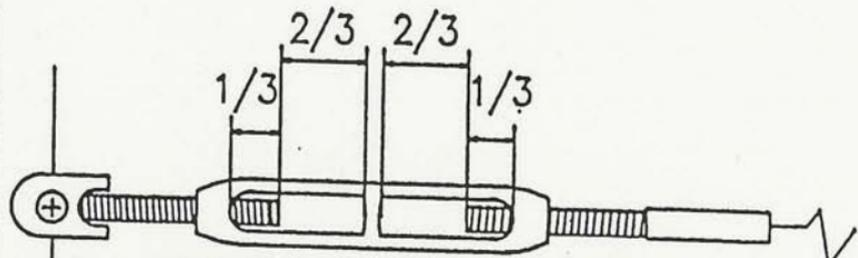

TURNBUCKLE

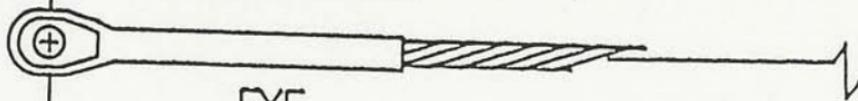

EYE

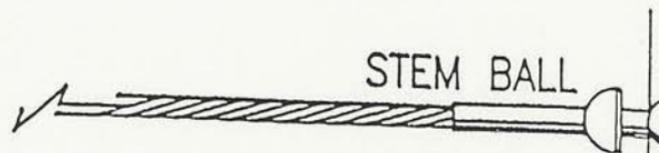

STEM BALL



T-BALL



EYE

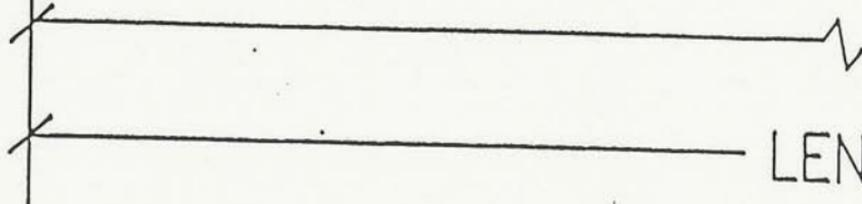

LENGTH

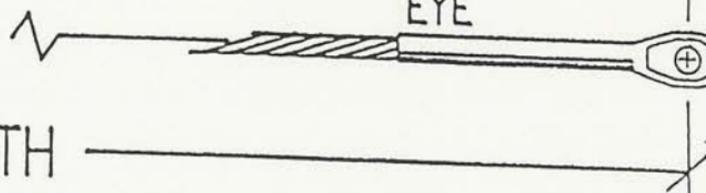

LENGTH

BRIEF GLOSSARY *(Continued)*

- MAST STEP:** A metal fitting that holds the base of the mast in position.
- OUTHAUL:** A line used to haul the clew of a sail out to the edge of the boom.
- PINTLES:** Pins on the forward side of a boat's rudder, designed to rest in and pivot on the gudgeons secured to the transom.
- REEFING:** To reduce a sail by rolling or folding up part of it.
- RIGGING:** The wire supporting the spars is called standing rigging (stays or shrouds), and the ropes used in setting and trimming sails are known as running rigging (halyards and sheets).
- ROLLER FURLING:** A means of reducing sail on a main or jib by rolling the sail around a rod or wire.
- SHACKLE:** A U-shaped piece of metal with a pin across the open ends.
- SHEET:** A rope used to trim a sail.
- SHROUD:** A length of wire used to support a spar (same as a "stay").
- SLACK:** The opposite of taut (i.e., *slack away or off*—to pay out).
- SPREADERS:** Aluminum tubes that project from a mast in a traverse direction in order to keep a stay at proper tension and to help hold the mast erect.
- STAY:** A length of wire used to support a spar (same as a "shroud").
- STEMHEAD FITTING:** The fitting nearest the bow on the deck where the headstay attaches.
- STEP:** To step a mast is to set it in position.
- TACK:** The lower forward corner of a sail.
- TILLER:** A piece of wood connected with the rudder head. By this the rudder is moved as desired.
- TOPPING LIFT:** A wire and/or rope that attaches to the top of the mast and fastens to the end of the boom. Its purpose is to hold the end of the boom up when the mainsail is lowered.
- TRIM:** To trim sails. To put them in correct relation to the wind by means of sheets.
- TURNBUCKLE:** A device used to maintain correct tension on rigging.

BRIEF GLOSSARY OF SAILING TERMS

- BATTEN:** A thin wooden or plastic strip placed in a pocket in the leech of a sail to help hold its form.
- BLOCK:** Pulley consisting of a frame in which is set one or more sheaves or rollers. Ropes are run over these rollers.
- BOOM:** Spar at the foot of the mainsail.
- BOOM VANG:** Tackle secured to the bottom of the boom about three feet aft of the gooseneck. The other block attaches to an eye at the base of the mast. The vang's purpose is to keep the boom steady and horizontal while sailing.
- CHAINPLATES:** Strips of metal fastened to the boat's hull or deck designed to take the stress of stays.
- CLEVIS PIN:** A small stainless steel pin that has a hole in one end for a cotter pin and is used to secure stays to chainplates and mast fittings.
- CLEW:** The aft-most lower corner of a sail.
- COTTER PIN:** A straight or circular split metal pin used to hold a clevis pin in place.
- DOWNHAUL:** A device used to tighten the luff of a sail.
- FAIRLEAD:** An eye used to lead line in the direction desired.
- FOOT:** The lower edge of a sail.
- GOOSENECK:** A metal device that secures the boom to the mast.
- GUDGEON:** A metal socket attached to the transom to receive the pintle of the rudder.
- GUNWALES:** The upper edge of a boat's side where it meets the deck.
- HALYARD:** A line for hoisting (or raising) the sails.
- HEAD:** The upper corner of a sail.
- HEADBOARD:** The fitting at the head of a sail with a hole in it to receive the main halyard.
- HEADSTAY:** The foremost stay on a sailboat. A jib is set on a headstay.
- JIB SNAPS:** Small fittings that are attached to the luff of a jib which secure the jib to the headstay.
- JIBE:** The action of the mainsail when shifting from one side of the boat to the other when heading downwind.
- JIFFY REEFING:** (*see "reefing"*) A quick method of reefing the mainsail, sometimes with one line.
- LEECH:** The aft edge of a sail.
- LUFF:** The forward edge of a sail.
- MAINSHEET:** The line used to trim a mainsail.
- MASTHEAD FITTING:** The fitting at the top of a mast.

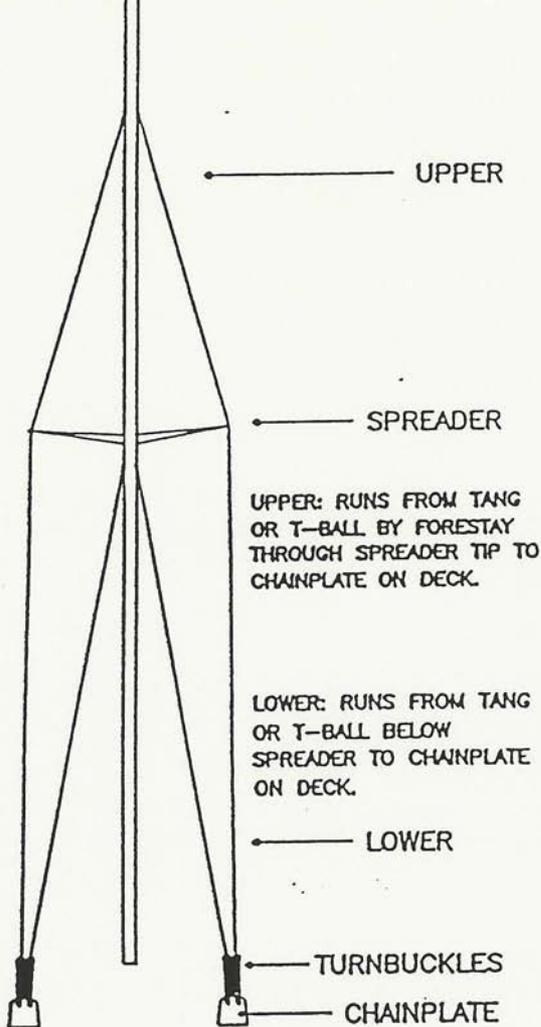

BACKSTAY: RUNS FROM MASTHEAD TO BACKSTAY-CHAINPLATE ON DECK.

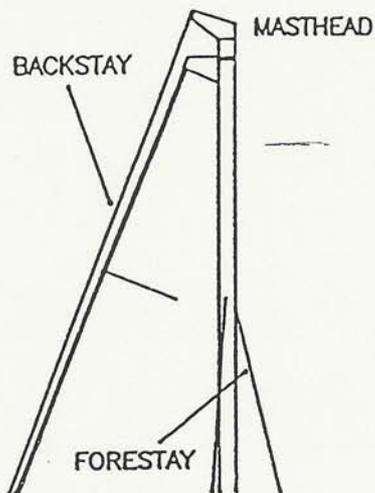

FORESTAY RUNS FROM A POINT APPROXIMATELY 20% BELOW MASTHEAD TO STEMHEAD FITTING.

HUNTER 

SINGLE SPREADER FRACTIONAL
RIG W/ SWEPT BACK SPREADERS
GEN2600A

FROM EXIT ON MAST

JIB HALYARD: EXITS MAST
AND WRAPS CLOCKWISE
AROUND WINCH.

MAIN HALYARD: EXITS FROM
BOTTOM OF MAST AND
WRAPS COUNTER-CLOCKWISE
AROUND MAST.

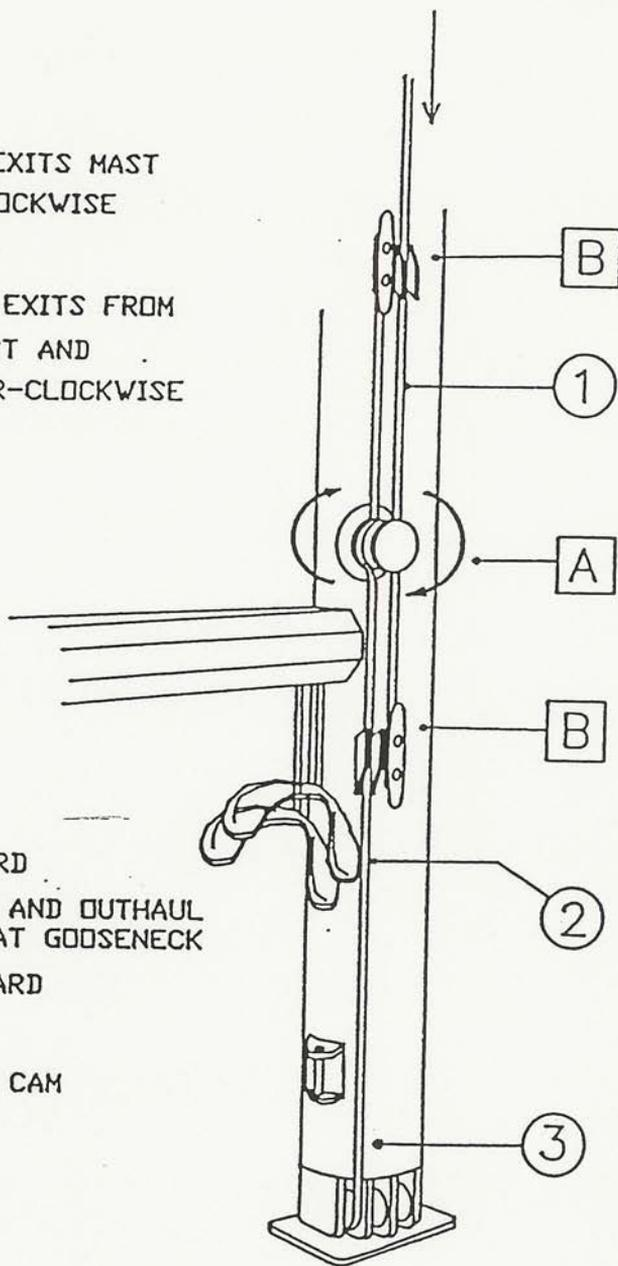

- ① JIB HALYARD
- ② REEF LINE AND OUTHAUL
TIED OFF AT GOOSENECK
- ③ MAIN HALYARD
- A WINCH
- B CLEAT AND CAM

HUNTER

BOOM AND REEF LAYOUT
GEN2615A
CONVENTIONAL REEF

VARIATIONS:

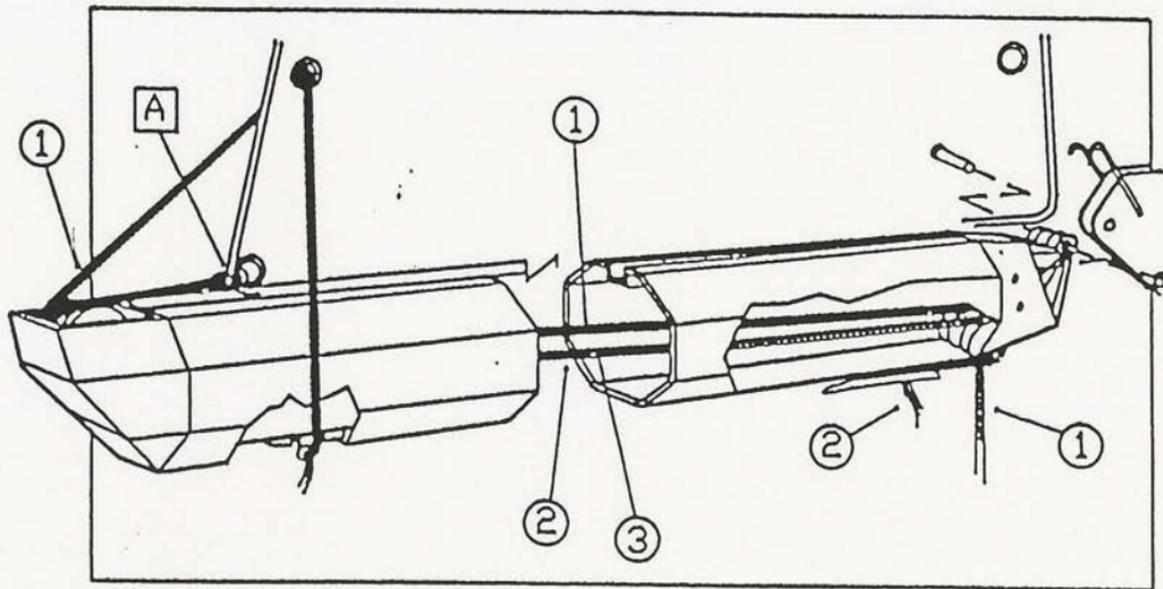
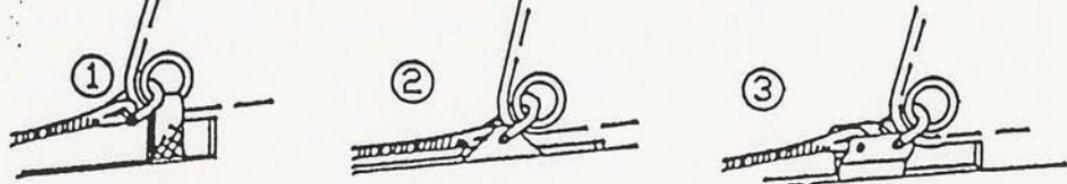

- ① REEF LINE
- ② OUTHAUL
- ③ TRANSITION FROM DH WIRE - DH LINE
- A D SHACKLE

E. Sail Care and Storage

Your Hunter or Legend comes with Dacron mainsail and 110% genoa jib. To extend the life of your sails and maintain their best performance:

1. Never use them in wind ranges that exceed their capabilities.
2. Never let them luff for extended periods of time.
3. Rinse your sails in freshwater whenever possible if you sail in saltwater. Tub wash them every few seasons to keep them bright and attractive. **CAUTION:** Do not machine wash. Use a mild detergent in warm water, and *remove all detergents completely with a thorough rinsing.*

For oil and grease stains, use commercial cleaning solvents. Should a yellow stain develop, bleach with oxalic acid and rinse thoroughly. Rust stains should be soaked in a warm solution of two parts hydrochloric acid per 100 parts water, rinsing thoroughly.

After rinsing your sails, spread them and allow to dry thoroughly before bagging. This is a good time to inspect them for minor damage. When dry, fold according to diagram. First spread sail on flat surface, then fold in a smooth, accordion pleat from the foot to the head. Next, roll the folded sail from the tack to the clew and slide carefully into bag.

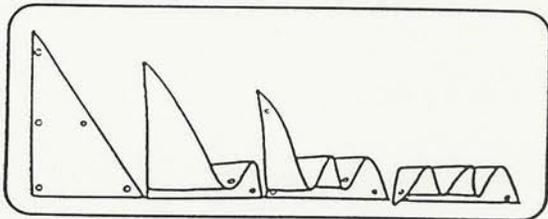

At the end of each season, it is good practice to have your local sailmaker inspect your sails for signs of wear and tear.

F. Care of Standing Rigging

The stays and shrouds on your Hunter or Legend are highly durable stainless steel to insure years of reliable service. To protect your standing rigging, keep it clean and, whenever possible, rinse thoroughly with freshwater. Check occasionally for "fish hooks," strands of wire that have broken and curled outward. These can snag sails and inflict painful cuts in bare hands. Broken strands indicate the wire is deteriorating and should be replaced.

Also inspect turnbuckles regularly and replace any missing cotter pins. Occasional lubricating improves both the life and the function of the turnbuckles.

G. Care of Running Rigging

To protect your running rigging (sheets, halyards) from damage, wash with cold water (and a mild detergent, if necessary), especially after exposure to saltwater. Rinse thoroughly and coil. Hang the tail ends of halyards off the deck to promote drying. Sheets should also be hung to dry.

Inspect all lines periodically for fraying and other damage. Lines showing substantial wear should be replaced.

H. Stepping the Mast On the Hunter 23

Hunter Marine recommends that you walk through the following seven steps and assign each person their respective task and positions during the stepping of the mast. Sailing is a fun and safe sport when the crew operates as a team. Good luck and smooth sailing.

III. Sails & Rigging

A. Tuning the Conventional Fractional Rig (Hunter 23, Hunter 26.5, Hunter 333, Legend 35, Legend 37)

TUNING THE RIGGING:

After raising your mast, attach the headstay, backstay, upper shrouds and lower shrouds. Set the headstay turnbuckle at half open and then tighten backstay turnbuckle to medium tension.

To center the mast athwartships, start with only slight tension on the upper and lower shrouds. Check that the mast is centered in the boat by measuring

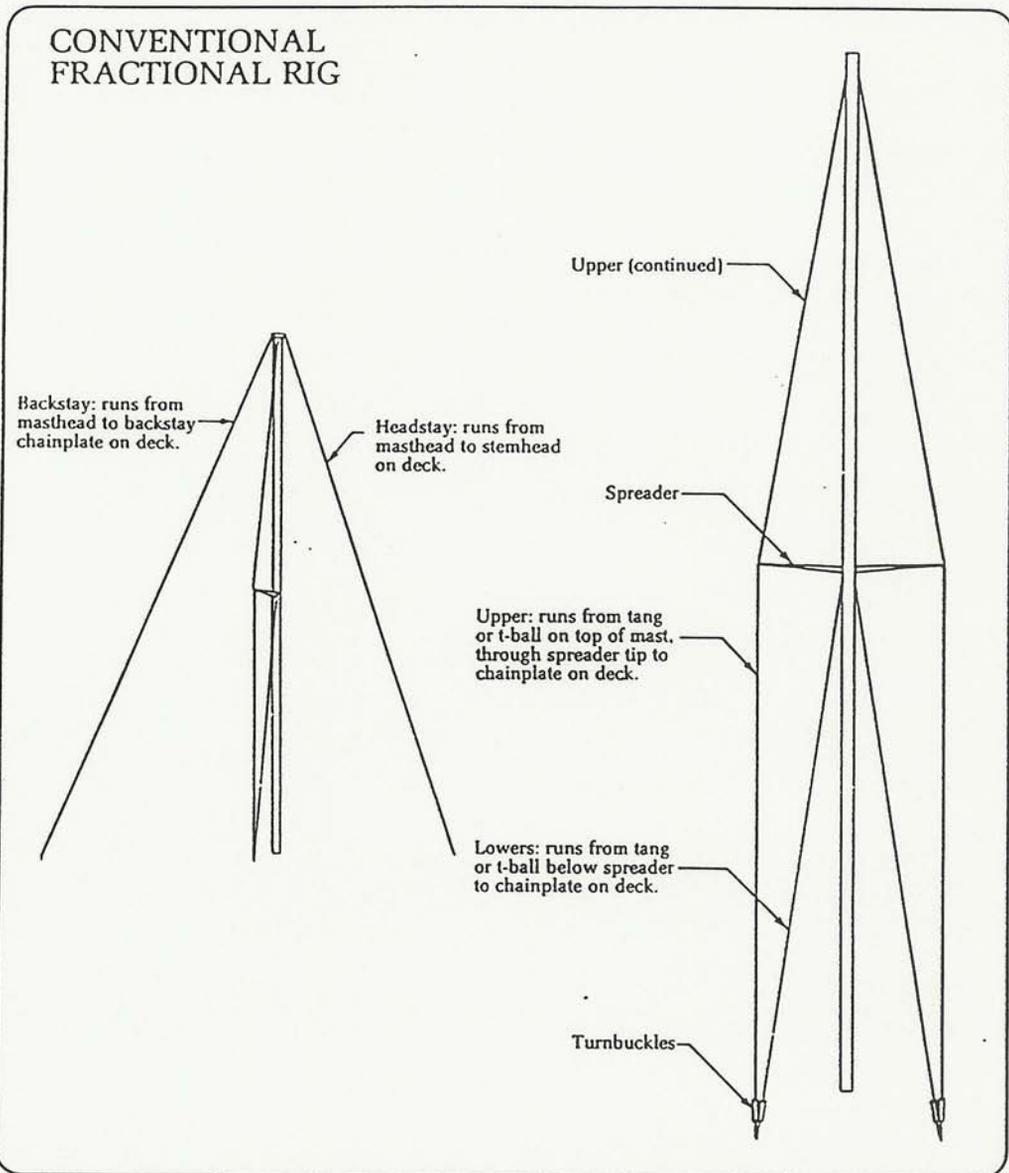

from the masthead to the chainplates with a steel tape measure hoisted completely up the main halyard. Adjust the upper shroud until the measurements port and starboard are exactly the same. Now the spar is plumb athwartships, tension both uppers equally, counting turnbuckle revolutions as you go. Tighten uppers until you have approximately one inch of "prebend" fore and aft in the mast. This is achieved because the swept spreaders will push the middle part of the mast forward as you increase tension of the uppers.

Now tighten the lower shrouds evenly, making sure the mast remains straight athwartship. Sight up the luff groove to assure this straightness. Lower shrouds should end up almost as tight as the uppers. (The uppers should always be the tightest.) Both the Legend 35 and Legend 37 are equipped with double spreaders. The three shrouds should be made progressively tighter toward the top of the rig; the uppers should be the tightest of all. Tighten backstay to a taut position: perhaps eight to ten turns past your original tension.

Check the mast tuning by sailing in medium winds (10-12 knots). Sometimes fine tuning the upper and lower shrouds is necessary when the spar is loaded in sailing conditions. Sail on both tacks, sighting up the luff groove to check athwartship straightness. Both upper and lower shrouds should be taut on the leeward side.

When mast tuning is complete, install cotter pins in all turnbuckles and tape over sharp edges of the cotter pins with chafe tape.

P Tuning the B&R Rig (Hunter 28.5, Legend 40, Legend 45)

NOMENCLATURE DESIGNATION:

upper-upper	D3*
lower-upper	V2
lower-intermediate	V1
lower	D1
upper-intermediate	D2*
lower-diamond	d1
upper-diamond	d2

*D2 and D3 are cut to a fixed length (no turnbuckles).

Initial tuning is best accomplished before the mast is stepped.

Support the mast, forward side down, about one-quarter of its length from the end and at its center. Once the mast is supported, make certain that it has no bow in any direction. Attach a small string from the masthead, in line with the sail track groove, to the base of the mast, stretching it as tight as possible. Check to make sure it is a constant distance from the mast along the entire length.

You are now ready to "tune in" the desired mast bend, which is one percent of the mast height above the boom ($.01 \times$ mast height above boom). On a 50' mast, this would be .5 feet at the mid-point of the mast.

Using the rigging diagram, locate d1 and d2. Before tuning, make sure the turnbuckles are adjusted back with equal thread showing. Carefully counting turns, adjust d1 port, d1 starboard, d2 port and d2 starboard evenly until the desired bend is induced. This is checked by measuring from the string down to the mast at the center of the mast.

It is important to make sure the mast is straight athwartships at this time.

You are now ready to step the mast.

Step the mast with all shrouds loosely attached.

Adjust the forestay and backstay to obtain the desired mast rake. The mast should be vertical or raked aft. The more rake, the greater the weather helm. The forestay and backstay should have a reasonable amount of tension on them.

Adjust V2 (port and starboard) evenly until they are tight. You should finish with approximately equal amounts of thread showing on each turnbuckle.

Using the jib halyard, check the mast for athwartship plumb. Pull the halyard out to the side of the boat and below the shear. Repeat the procedure on the opposite side. If you find a big difference (more than $\frac{1}{2}$ inch), adjust turnbuckles an equal amount in opposite directions until the mast is straight.

Adjust V1 (port and starboard) using the above procedure.

Repeat the procedure for D1 (port and starboard).

Your mast should now have the original "pre-bend" and be straight athwartship.

Check the mast tuning by sailing in medium winds (10 to 12 knots). Sail on both tacks, sighting up the luff groove to check athwartship straightness. Shrouds should not be loose on the leeward side. (This is especially important with the B&R rig.) Follow the progressive shroud tightness routine described in the tuning instructions for the conventional rig. When mast tuning is complete, install cotter pins in all turnbuckles and tape over sharp edges of the cotter pins with chafe tape.

B&R RIG

D3 upper upper:
runs from upper tang
to upper spreader tip.

Upper spreaders

V2 lower upper:
runs from upper
spreader tip through
lower spreader tip to
chainplate on deck.

D2 upper intermediate:
runs from tang below
upper spreaders to
lower spreader tips.

d2 upper diamond:
runs from upper
spreader tip to tang
above lower spreader.

Lower spreaders

V2 lower upper
(continued)

V1 lower intermediate:
runs from lower
spreader tip to
chainplate on deck.

d1 lower diamond:
runs from lower
spreader tip to tang
above bottom end of
mast extrusion.

D1 lower:
runs from tang below
lower spreader to
chainplate on deck.

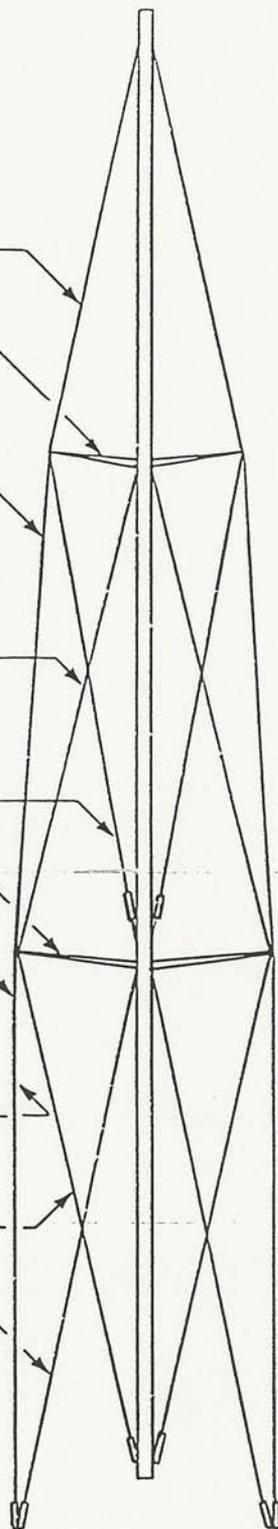

C. Roller Furling

OPERATING THE ROLLER FURLING:

1. To furl the sail, release the jib sheet and pull in on furling line from cockpit. Hand power is all that's needed; only special situations necessitate using a winch.
2. To roll the jib tightly around the headstay, it is advisable to keep some tension on the jib sheet. This can be done by holding the jib sheet and allowing it to slide through your fingers or by leaving two turns around a winch while furling. After jib has been completely furled, furling line should be cleated and jib sheet tensioned.
3. To unfurl, uncleat furling line, leaving one turn around the cleat for friction. This prevents snags on the drum. The jib sheet on leeward side of boat is then pulled to unfurl sail. It may be unrolled part-way or all the way, depending on wind conditions.

REEFING THE ROLLER FURLING SAIL:

1. The sail should be tightly rolled to maintain optimum sail shape. Leave two turns around the sheet winch with the tail of the jib sheet held loosely in your hand. Then pull the furling line in against tension of jib sheet to achieve the tightest roll (and, therefore, the best sail shape).
2. You may reef the sail to any point. Most any sail may be reefed except a large genoa which is specifically cut very full and has a lightweight cloth that cannot withstand the strain of reefing. (Consult a sailmaker if in doubt.)

D. Reefing the Mainsail

Your Hunter or Legend is equipped with an easy-to-use jiffy reefing system.

To reef the main:

1. Ease the mainsheet (boom vang if installed), making sure topping lift is secured in position.
2. Lower the main halyard so that tack reef cringle can be placed on gooseneck reef hook. Re-tension main halyard when hooked in place.
3. Clew reef line must now be tensioned so that clew reef cringle is brought down snugly against boom.
4. Readjust mainsheet and boom vang.
5. The reefed folds of cloth can be rolled up and secured with short lines through the reef points and around the folds and boom. **IMPORTANT:** Be sure to untie these first when shaking out the reef.
6. To unreef, reverse the procedure.

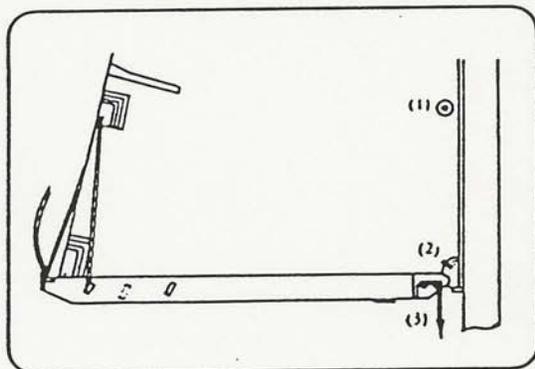



Mansfield® SaniPOTTIE® 943 & 944 Marine Portable Toilets

A few of the many SANI-POTTIE® features

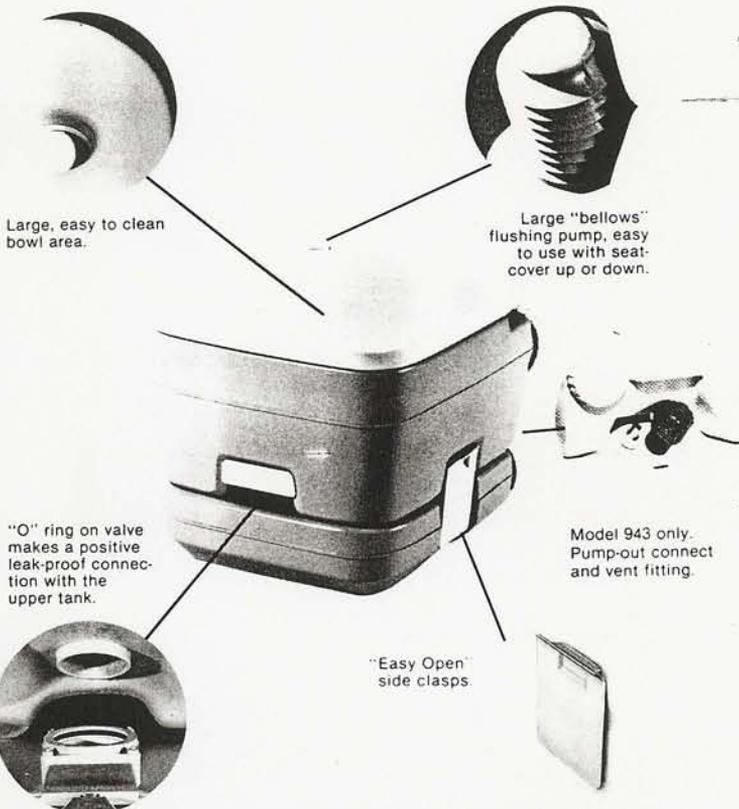

- At-home convenience, wherever you go.
- Compact, lightweight . . . crafted of corrosion-proof, heavy-duty polyethylene and styrene.
- Requires no external water or power source; operates on self-contained clean water supply; features gas-tight, odor-free valve seal.
- Simple to carry, operate and maintain.
- Available in two colors Parchment and Oxford — and all Parchment.
- Stainless steel hold-down brackets for secure mounting.

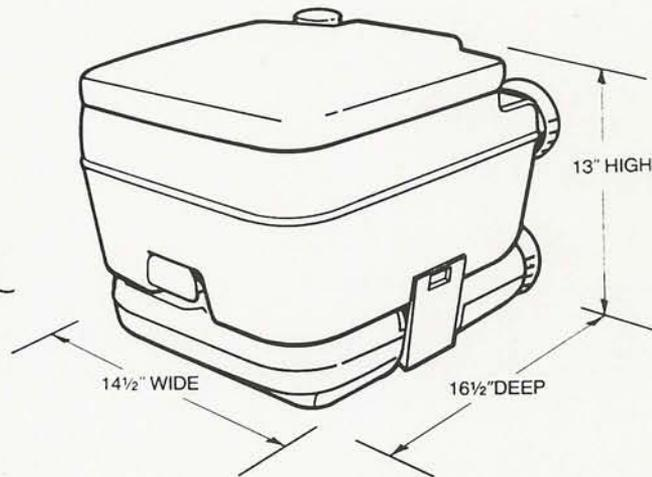

Use these specifications to order:

Order No.	Description	Approx. W
943	SANI POTTIE Marine Portable Toilet. Complete with stainless steel hold-down brackets, pump-out connection and vent fitting.	15
944	SANI POTTIE Marine Portable Toilet. Complete with stainless steel hold-down brackets only.	14

NOTE: Portable toilets are legally acceptable for use in vessels not having permanently installed toilets, as determined by U.S. Coast Guard Regulations. However, some states and the Canadian province of Ontario do not permit portable toilets.

Mansfield Plumbing Products

BIG PRAIRIE, OHIO 44611 / TELEPHONE (216) 496-3211

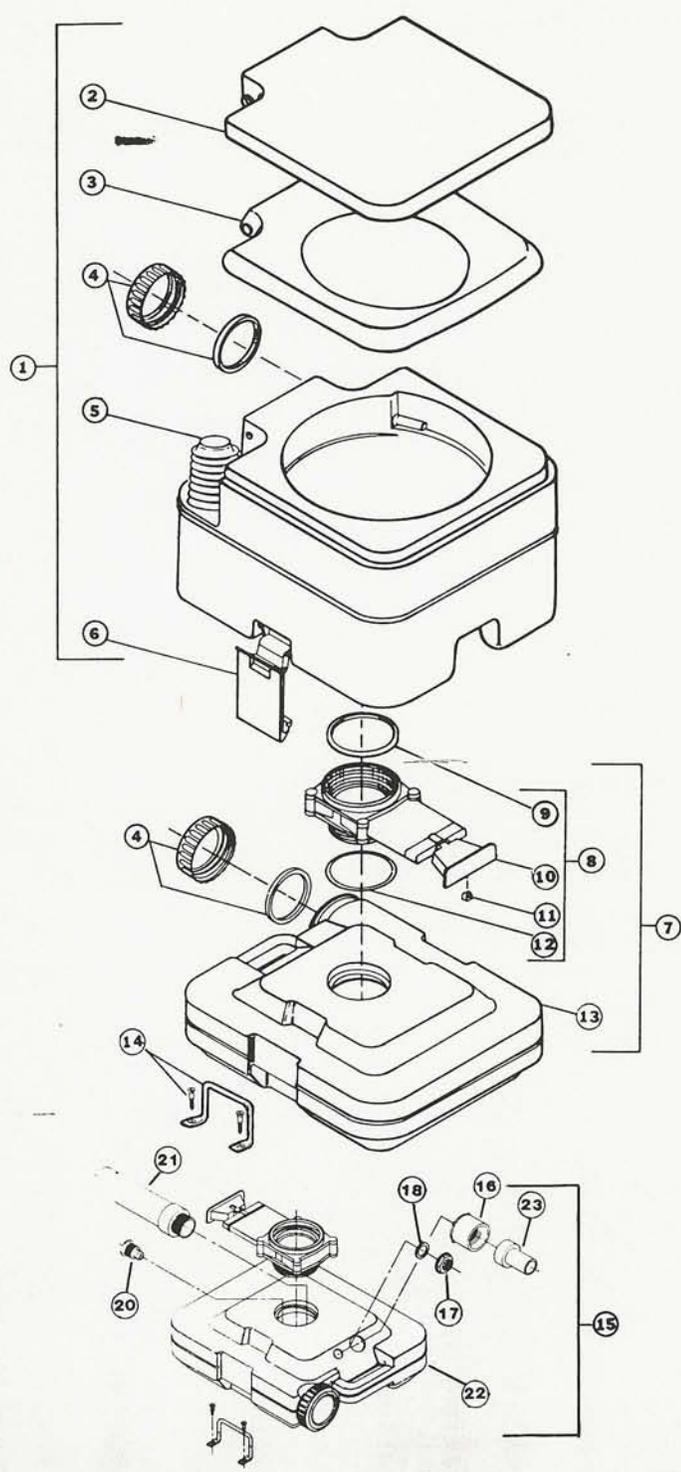

SANI-POTTIE® Replacement Parts List

Item	Part No.	Description
1.	123-0173	Fresh Water Tk Assy. all PAR
	123-0172	Fresh Water Tk Assy. W/Oxford Seat
2.	312-0003	Cover, Seat OXF
	312-0013	Cover, Seat PAR
	645-0001	Hinge Pin OXF
	645-0012	Hinge Pin PAR
3.	747-0011	Seat, OXF
	747-0018	Seat, PAR
4.	531-0041	Kit, Cap & Seal OXF (2 Each)
	531-0050	Kit, Cap & Seal PAR (2 Each)
5.	531-0039	Kit, Bellows Pump PAR
6.	123-0116	Assy., Plastic Latch OXF
	123-0151	Assy., Plastic Latch PAR
7.	123-0167	944 Assy., Hldg Tank PAR
	123-0168	944 Assy., Hldg Tank OXF
8.	123-0177	Assy., Slide Valve OXF W/O-Rings
	123-0187	Assy., Slide Valve PAR W/O-Rings
9.	612-6549	Top O-Ring
10.	468-0010	Handle OXF
	468-0015	Handle PAR
11.	273-6911	Handle Clip
12.	612-6401	Bottom O-Ring
13.	864-0013	Holding Tank Only OXF (944)
	864-9001	Holding Tank Only PAR (944)
14.	531-0018	Kit, Hold Down Brkt.
943 Holding Tank Assy.		
15.	123-0112	Assy., Holding Tank PAR
	123-0118	Assy., Holding Tank OXF
	123-0169	Assy., Holding Tank/SL VLV PAR
	123-0170	Assy., Holding Tank/SL VLV OXF
16.	123-0162	Assy., Outlet Adapter
17.	582-7068	Locknut
18.	447-1583	Fiber Gasket
19.	687-6606	Sealant 2" (not shown)
20.	420-0001	Fitting
21.	123-0076	Dip Tube
22.	864-0008	Holding Tank Only PAR
	864-0016	Holding Tank Only OXF
23.	105-0013	1-1/2" Hose Adapter

Chemical and Tissue

- 261-0004 Waste Be Gone Powder Chemical — 6-2 oz. PKT
- 261-0006 Waste Be Gone Liquid Chemical — 1-12 oz. BOT
- 639-8634 Sani-Soft — 4 Pack Tissue



TEKNISKA DATA:

Höjd: ca 137 mm (inkl. kokkärilsstöd)
Bredd: ca 275 mm
Längd: ca 464 mm (1500, ca 236 mm)
Kapacitet: ca 1,2 liter per behållare
t: 1 liter vatten kokar på 6—8 min.
ansle: T-sprit (T-röd)

INSTRUCTIONS

ORIGO 1500 and 3000 are non-pressurized alcohol stoves with the fuel absorbed in a non-flammable pulpe. They have no valves to develop leaks, or other components in need of regular service. This makes ORIGO 1500 and 3000 safe and easy to maintain.

As always — when working with a naked flame — certain precautions are required. So, read the following simple instructions carefully before using your new ORIGO 1500 and 3000 stove.

If an accident should ever occur, remember that burning alcohol can be extinguished with water.

LOCATION OF YOUR NEW ORIGO 1500 AND 3000

Your stove should be located in a well-ventilated space. Avoid excessive draft. If f.inst. your ORIGO 1500 and 3000 is used in an open cockpit, it should be placed so that maximum protection against the wind is obtained. Mount the stove as far away from combustible materials as possible. Preferably mount the stove in a metal-lined space.

TO FILL, OPEN THE STOVE TOP

Turn the knobs to 0 position, burner openings fully covered. Pull the forward lower edge of the stove top slightly forward, while ultaneously pressing the catch PRESS (photo 1).

Stove must not be filled near an open flame or a hot object. The stove top can only be opened when the burner openings are completely covered by the regulating plates. Turn the regulator knobs clockwise as far as they go, and the flames are extinguished. Lift out tank unit. It is essential that not only has the flame been completely extinguished, but that there is no heat grow on burner top.

During use, the tanks are heated, and the fuel requires space to expand. It is therefore important to avoid overfilling the tanks.

The tank openings are recessed to facilitate filling. Hold the tank as shown in photo 2, with the recess pointing down, and pour the fuel directly into the opening covered by the wire mesh. Check quantity by raising to vertical. When fuel is visible in recess, do not fill more (photo 3). After filling, make certain no excess fuel remains in stove. Always wipe tanks dry. Place tanks in stove. Check that they fit properly in mountings. Close the stove up.

Closing: Knobs in 0 position! Fold down the stove top, the catch will lock. (Make certain that the regulating plates cover the burner openings so that stove top is level.)

TO LIGHT (PHOTO 4)

Turn regulator knob counter-clockwise to open burner. Place a lighted match at burner opening. (Match can be dropped in and removed at next filling.)

If the stove is warm (from previous use), burner may ignite suddenly and simultaneously snuff itself out. If this happens, blow down into burner opening to dissipate alcohol vapor, and relight. The Origo-lighter is recommended. Winterize your stove by burning remaining fuel.

EXTINGUISH

Turn regulator knob clockwise.

TO REMOVE GRID (PHOTO 5)

At the back of the stove top is an oblong hole, into which the grid retaining hook fits. To remove grid, slide it out of the retaining hole and it can be lifted off.

Balansupphängning
Kokkärilshållare
Gaständare

ORIGOVERKEN

Box 171
301 03 HALMSTAD

GIMBALS

Gimbals for ORIGO 1500 and 3000 are optional. Your ORIGO 1500 and 3000 gimbals should be mounted as follows: The gimbal side-plates are fastened to the lower body of the stove by the enclosed nuts and bolts (see illustr. 6). They can only be attached in one way.

The gimbal arms, however, can be turned to enable the stove to be lowered forwards or backwards. Before mounting the gimbal arms, make a test by attaching them to the gimbal plates in order to determine which alternative is right for your boat. Remember that the stove top must be raised to full upright position in order to remove burner units for filling, when the gimbals are in down position. Also be sure that your ORIGO 1500 and 3000 stove has sufficient room to swing freely when gimbals are used. Take care that stove is not mounted too close to combustible materials, or materials likely to deteriorate from the heat. When lifting the stove into position you fasten the gimbal side plates to the gimbal arms at the pivot point using the two special thumb screws supplied. Be sure that the installation is done in the correct sequence.

Fiber washers with round holes must be placed on the gimbal arm side. Then hang stove. Place fiber washers with oblong hole between body of stove and gimbal plate. They are cut to fit the end of the plate, and fasten the screws. Adjust the tension of the screws to the desired friction.

GASKETS

The stove is delivered with gaskets on top of the tanks. These are to be used if you are not using your stove for some time. Can also be used to prevent evaporation in hot climate.

Use this way: fold up the stovetop, check that the stove has become cold. Put the gaskets over the tank openings. Fold down the stovetop to horizontal position and open the burners to lock the top in closed position.

TECHNICAL DATA:

Height: approx. 5 3/8" (137 mm) incl. cooking grid
Depth: approx. 10 7/8 275 mm
Length: approx. 18 1/4 464 mm (1500, 9 5/16" 236 mm)
Fuel tanks: approx. 2.5 pints each tanks (1,2 l.)
Fuel: denatured alcohol, methylated spirit
Efficiency: will boil 2 pints of water in 7 minutes (per burner)

OPTIONAL EXTRAS

Gimbals
Potholders
Lighter

WARNING

To be used only with denatured alcohol. Must never be used with gasoline, kerosene, diesel or any other type of fuels.

ORIGOVERKEN

Box 171
S-301 03 HALMSTAD
SWEDEN

ORIGO USA INC.

1121 LEWIS AVE. — SARASOTA
FLORIDA 33577

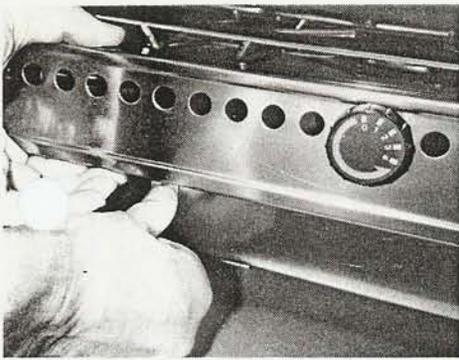

1

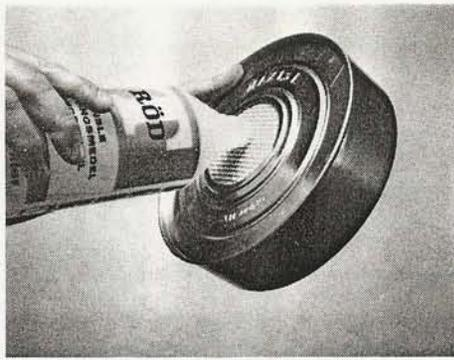

2

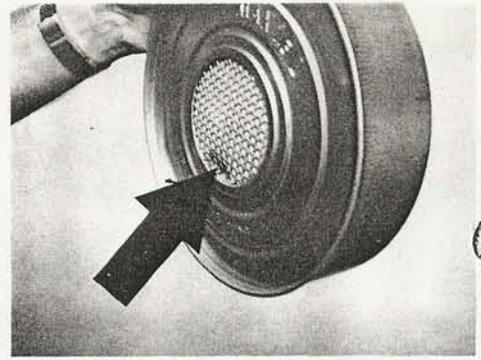

3

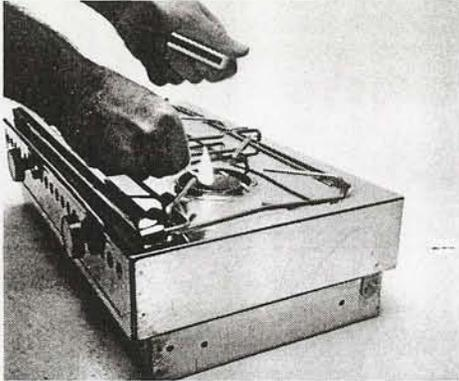

4

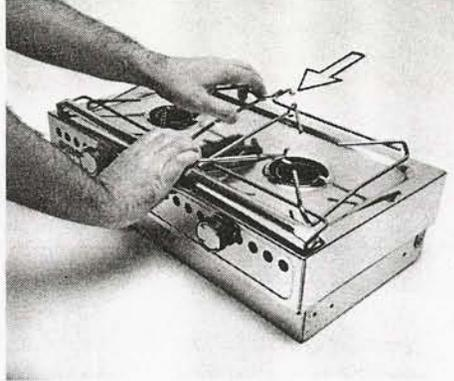

5

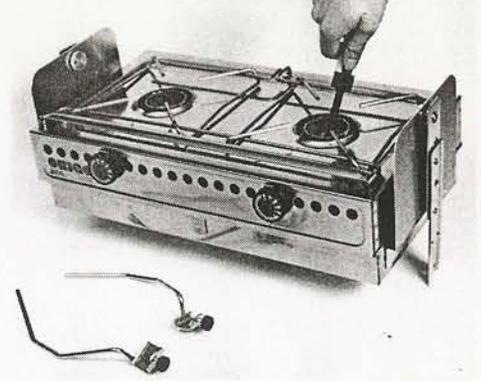

6

BRUKSANVISNING

ORIGO 1500 och 3000 är spritkök som arbetar utan övertryck och som har bränslet absorberat i en eldhärdig massa. De har dessutom inga känsliga ventiler eller andra delar som behöver regelbunden service. Detta gör köken mycket lättskötta och säkra.

Som alltid då man har att göra med öppen eld måste man naturligtvis iakttaga viss försiktighet. Läs därför noga igenom följande enkla anvisningar innan Ni använder Ert nya kök.

Om spritbrand trots allt någon gång skulle uppstå så kom ihåg att den kan släckas med vatten.

KÖKETS PLACERING

Köket skall endast användas i ett väl ventilerat utrymme. Man bör dock undvika alltför kraftigt drag eller blåst. Om det användes t.ex. i en öppen sittbrunn, bör man placera det så att bästa möjliga vindskydd erhålles. Placeringen bör även vara sådan att man får största möjliga avstånd till omgivande brännbara eller mindre värmetåligena material. Det bästa är om köket monteras i ett plåtklätt utrymme.

PÅFYLLNING

Får ej ske i närheten av öppen eld eller heta föremål. Uppfällning av hällen: Rattarna i läge 0 så att behållaröppningarna är helt täckta. Hällens nedre framkant drages lätt framåt samtidigt som man trycker på spärren PRESS (enl. bild 1).

Lyft ur behållarna. Kontrollera att lågorna är helt släckta och att ingen glöd finns i behållaröppningarna. Då köket användes uppvärms behållarna, varvid spriten utvidgas och behöver visst expansionsutrymme. Det är därför nödvändigt att inte överfylla behållarna.

Behållaröppningarna har en försänkning vid kanten för att underlätta påfyllningen. Håll behållaren som bild 2 visar, med försänkningen nedåt, och håll spriten direkt mot öppningens nätt. Påfylld mängd kontrolleras genom att behållaren hålles på högkant som på bild 3. Fyllningen kan ske tills spritytan blir synlig i försänkningen vid behållaröppningens nedre kant. Efter påfyllning — se till ingen utspild sprit finnes i köket. Torka alltid av behållarna. Ställ ned behållarna — kontrollera att de passar in mellan styrningarna. Nedfällning av hällen: Rattarna i läge 0 som ovan. Hällen fälls ned så att spärren låser.

TÄNDNING (BILD 4)

Öppna brännaren med regleringsratten genom vridning åt vänster

Stick ned en brinnande tändsticka i brännaröppningen. Tändstickan kan släppas ned i brännaren och tas bort vid nästa påfyllning.

Om brännaren tändes häftigt så att lågan blåses ut (kan inträffa om behållaren är ljummen) — håll en brinnande tändsticka i beredskap — blås kraftigt ned i brännaröppningen och tänd omedelbart. (Använd ev. braständsticka eller ORIGOs gaständare).

Om köket skall stå oanvänt en längre tid är det lämpligt att låta spriten brinna slut i behållarna.

SLÄCKNING

Vrid regleringsratten åt höger så långt det går.

DEMONTERING AV KOKKÄRLSSTÖD (BILD 5)

På hällens ovasida finns på bakkantens mitt ett avlångt hål. Om stödet vid denna punkt pressas mot kökets framsida kan det lyftas ur hålet och tas upp. Fäll och lyft sedan av det.

BALANSUPPHÄNGNING

Som extra tillbehör finns balansupphängning, som monteras på följande sätt:

Gavelplåtarna fästes vid kökets underdel med hjälp av medföljande skruvar och muttrar (se bild 6). De kan endast monteras på ett sätt. Upphållningsarmarna kan däremot vändas så att köket kan sänkas ned framåt eller bakåt. Innan Ni bestämmer hur armarna skall sitta så gör ett prov genom att montera fast dem vid gavelplåtarna och undersök vilket alternativ som passar bäst i Er båt. Tänk på att hällen skall kunna fällas upp vid påfyllning då köket är nedsänkt. Andra viktiga faktorer att taga hänsyn till är att köket i uppfällt läge får tillräcklig plats att pendla både framåt och bakåt. Var också, som tidigare nämnts, noga med att det inte hamnar för nära något mindre värmetåligena eller brännbart material.

När Ni slutgiltigt hänger upp köket genom att fästa gavelplåtarna vid upphållningsarmarnas axeltappar, är det viktigt att de olika detaljerna monteras i rätt ordning. De fiberbrickor som har runt hål skall sitta innerst på tapparna. Häng därefter upp köket. Trä på de brickor som har avlångt hål så att de passar i tapparnas avfräsningar och skruva till slut i spännskruvarna. Justera skruvarnas åtdragning så att önskad friktion erhålles.

Köket levereras med packningar för bränslebehållarna. Dessa kan användas om köket står oanvänt under en längre tid samt vid varm väderlek för att hindra spriten att avdunsta.

Gör så här: fäll upp hällen — kontrollera att köket svalnat. Lågg

ORIGO 1500, 3000

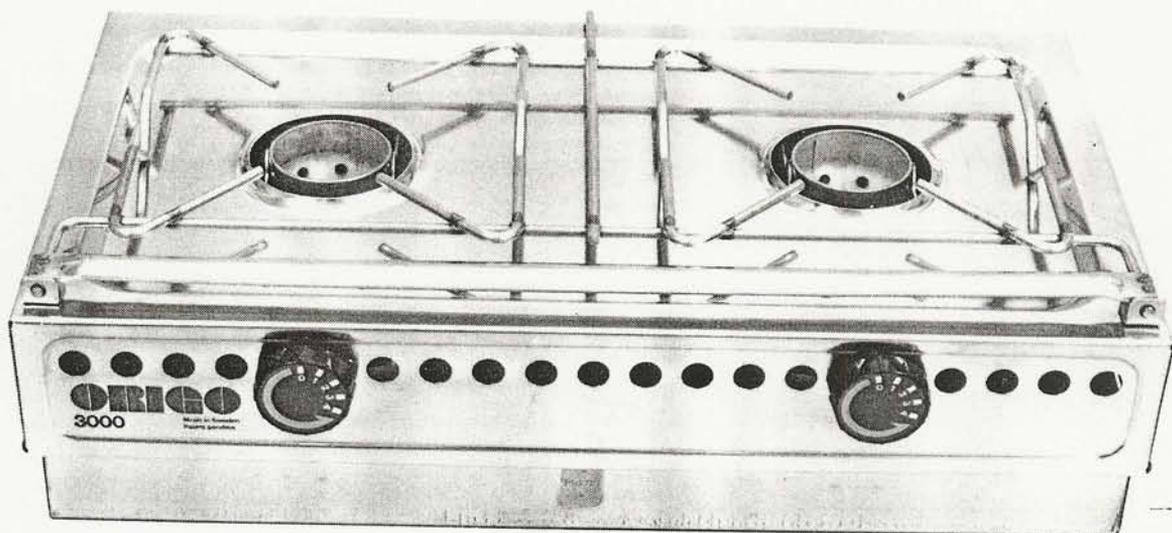
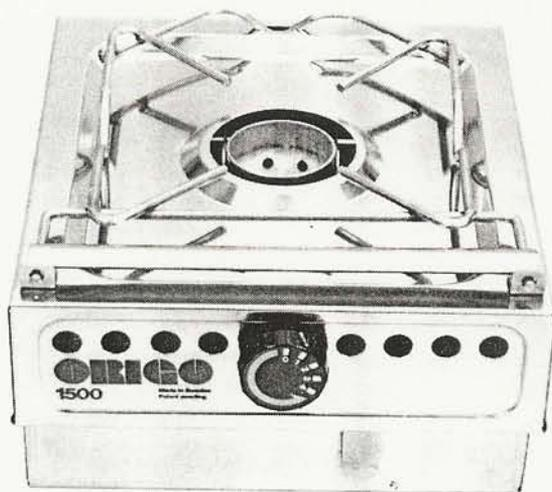

BRUKSANVISNING

INSTRUCTIONS

GEBRAUCHSANWEISUNG

STORAGE/WINTERIZATION CONTINUED.

ENGINE

1. Drain the cooling water completely out of the engine and flush the line thoroughly with fresh water. Don't use high pressure through the line.
2. Remove the fuel completely from all fuel lines.
3. Disconnect the main battery cables from the battery terminals.
4. To prevent corrosion inside the cylinders, pour a little lubricating oil into the suction pipe while turning the engine. Enough oil to reach the intake/exhaust valve is sufficient.
5. Put the piston at top dead center of compression stroke so that the intake/exhaust valves are completely closed.
6. Apply a thin anti-corrosion treatment to the plating and exposed painted surfaces.
7. The engine should be in a well ventilated area, and protected from any kind of dampness.
8. Put a dust cover over the engine.
9. Check your operation manual for engine diagram and for "Manufacturer's Recommended Winterizing Procedures."

OUTBOARD ENGINE

Take it home and store it in a safe place. Be very careful storing the gas tank as the gasoline is very flammable. Refer to "Engine Manual" for specific maintenance schedule.

DEPARTURE FROM THE BOAT

The check list for leaving a boat unattended is very important because items overlooked often will not be remembered until you are far from the boat and corrective actions are impractical or impossible. Primary choices for this list are items relating to the safety and security of the unattended craft—turning off fuel valves, the proper settings for electrical switches, pumping out the bilge and leaving the switch on automatic (or arranging for periodic pumping out). Other departure check list items are securing ports, windows, hatches, and doors.

ROUTINE MAINTENANCE

Routine maintenance check lists should include items based on how much the boat is used (usually in terms of engine hours) and on calendar dates (weekly, monthly, or seasonal checks). Typical of the former are oil level checks and changes, and oil and fuel filter changes.

On a calendar basis the lists should note such matters as electrolyte levels in storage-batteries, pressure gauges on dry-chemical fire extinguishers, and all navigation lights. Check the operation of automatic bilge alarms or pump switches by running water into the boat. Periodically close and open seacocks several times to ensure their free and easy operation in case they are needed in an emergency. Equipment and supplies carried on board for emergencies should be inspected for any signs of deterioration.

PROTECTING YOUR RIGGING

No matter how good your rigging is, without careful inspection and proper maintenance it is subject to fatigue, wear, discoloration, and, therefore, product failure. Remembering to inspect and clean will increase the life of your investment and secure your rigging. We would like to suggest the following:

■ Always rinse your rigging with fresh water after sailing. Especially after saltwater sailing. Salt can create corrosion pits, causing cracks and deterioration. In these severe corrosion conditions we recommend using high corrosion resistant alloy type 316.

■ Clean with a water soluble detergent *without* chlorine. Non-abrasive cleansers are best for hard white vinyl coated cables.

■ Store wrapped rigging with twine. *Never* use tape. Tape causes moisture, attracts dirt, and leaves residue that creates corrosion.

■ Inspect rigging for stains. Rust stains may indicate stress cracks or corrosion. Remove stains with synthetic or brass pads. *Never* use steel wool pads.

■ Look for broken wires - a sign of fatigue in rigging. Replace standing rigging if wires are broken.

■ *Never* mix stainless steel and galvanized metals on cable, fittings, pins, cotter keys, etc. If mixing dissimilar metals, electric currents may conduct between metal causing rapid deterioration.

■ After un-stepping, make sure to release all standing rigging to avoid bending, crushing, and kinking.

■ Store rigging in a dry place. *Never* store in a plastic bag. Plastic, like tape, causes corrosion.

MANUFACTURED BY:

**Carolina
Steel & Wire**
CORPORATION

**Carolina
Steel & Wire**
CORPORATION

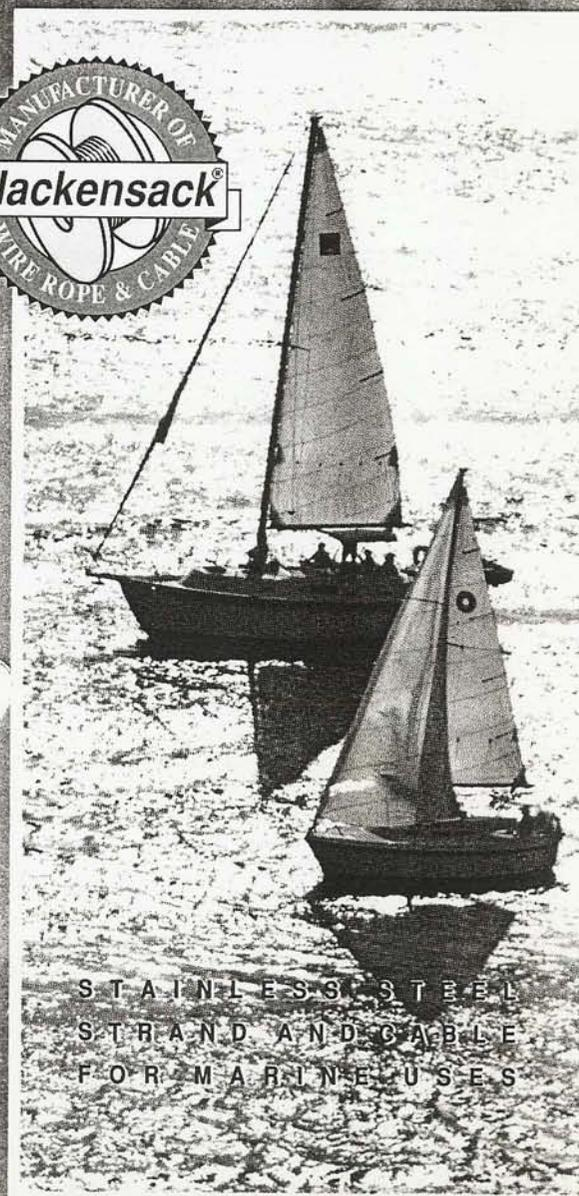

D I S T R I B U T E D B Y :

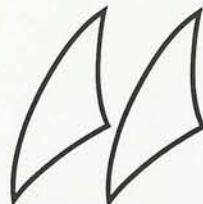

SECO SOUTH

P.O. Box 1158, Largo, Florida 34649-1158
Telephone (813) 536-1924. FAX (813) 539-6314.
2050 34th Way, Largo, Florida 34641.

STAINLESS STEEL
STRAND AND CABLE
FOR MARINE USES

HULL SPEEDS

Best Expected

22	5.5 <i>Knots</i>
23	5.75
25.5	6
28.5	6.25
31	6.5
34	6.75
37 Old	7
37 New	7.25
40	7.5
45	8.0

You will start off by raising the boom crutch to its highest position. Then walk the mast aft with the main-sail track down until the base of the mast lines up with the mast step. Position the mast correctly in the step and have the crew member designated push the pin through the aft hole connecting the two parts at the step to form a hinge.

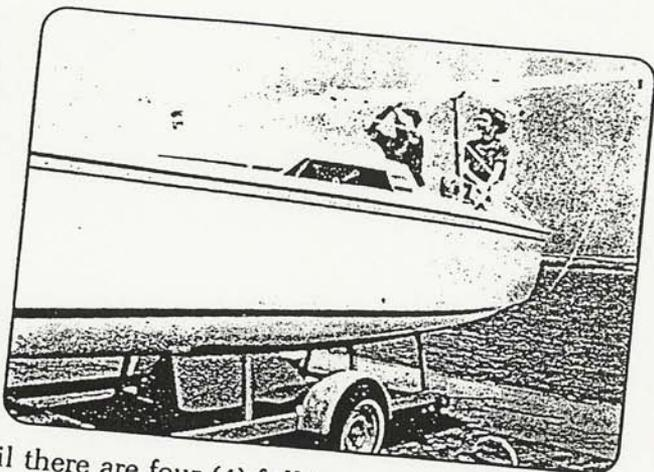

Loosen all turnbuckles until there are four (4) full turns on each end and then attach the uppers, lowers and the backstay to the appropriate chainplates. Attach a swivel block, not included, to the mooring pin in the bow. Tie the jib sheet to the forestay turnbuckle with a bowline and lead the sheet through the swivel block and aft to one of the jib sheet winches.

You are now ready to raise the mast. (We suggest that you double-check these procedures one more time before going to step two.)

STEP 2:

The strongest of the crew members will be the one to raise the mast as far as possible while standing in the cockpit at the forward end while another crew member puts tension on the line attached to the headstay by cranking the jib sheet winch with the winch handle. Tighten this line as tight as you can.

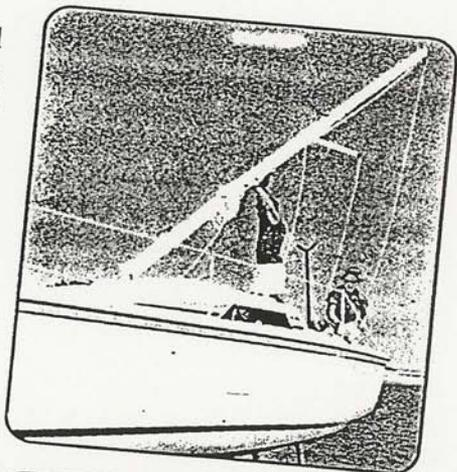

STEP 3:

After making sure that the headstay line is fully supporting the mast and is now securely cleated, the crew members change places; the crew member at the winch takes the place of the crew member at the mast vice versa.

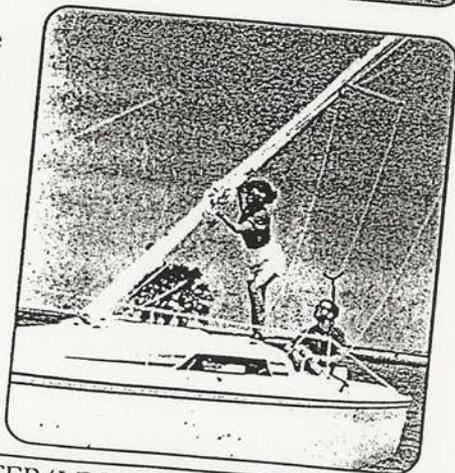

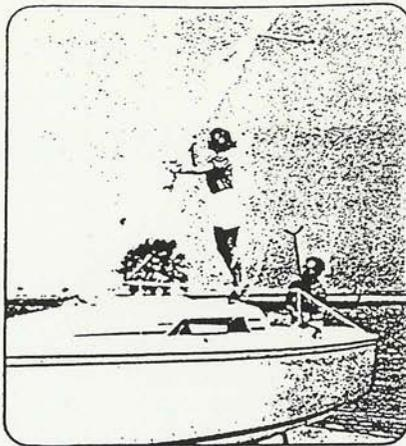

STEP 4:

The mast continues to be raised by a joint effort of cranking the winch while at the same time hoisting/guiding the mast easily, as the headstay line will carry the bulk of the weight. Team effort here pays off. Be sure it doesn't lean from side to side; keep it straight as it goes up.

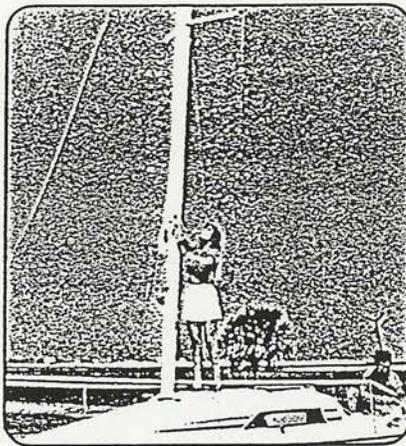

STEP 5:

The crew member guiding the mast upward holds it in the upright position while the crew member at the winch goes forward. Disconnect the headstay line and attach the headstay to the chainplate.



STEP 6:

All you need to do now is insert the forward pin through the holes at the mast step, thereby securing the mast to the mast step and deck. The other crew member continues to hold the mast steady during this final procedure.

STEP 7:

Now all you have left to do is tighten and tune the rigging, attach the sails and give your Hunter 23 the "once over" before backing the trailer into the water and setting out to sea. Make sure all your gear is properly stowed, your car is locked and you have the keys, and then you're ready for any adventure awaiting you and your crew.

HUNTER 23 MOTOR:

The Hunter 23 outboard motor should be operated in accordance with the instructions provided by the manufacturer.

As a precaution to insure that you do not lose the outboard if the clamp comes loose, *always have a safety line attached from the motor to the boat.*

HUNTER 23 TRAILER:

It is recommended that you maintain your trailer weight at approximately 225 pounds.

IV. Maintenance

A. Engine, Transmission and Drivetrain

ENGINE:

Follow the fuel and lubrication requirements in the Engine Manual. Check the engine oil level before and after operation and use quality motor oil (refer to Engine Manual). Be certain the proper amount of oil is in the crankcase at all times.

Engine alignment: The engine should be aligned by experienced marine service personnel. Final alignment should be done after launching, with all normal gear aboard. A description of the procedure follows:

The coupling flanges must come together evenly at all points, a feeler gauge is used to check the gap. If adjustment is necessary, the engine is tilted up or down and/or side to side until the flanges meet equally. Severe vibration will result from misalignment and can cause strut bearing and shaft damage.

Alignment should be checked again after several weeks of use. (Refer to this manual's alignment drawing.)

TRANSMISSION:

Follow the lubrication requirements of the Engine Manual. The oil level should be checked immediately after operation.

DRIVETRAIN:

The shaft log (stuffing box) should be inspected periodically.

The stuffing box is held to the shaft log tube by a rubber tube secured by hose clamps. The clamps should be tight and no water should leak from this location. A slight drip from the stuffing box at the shaft exit is necessary (four drops a minute) and normal.

To adjust, loosen the lock nut, tighten gland nut one-quarter turn, and retighten lock nut. If excessive water flow persists after adjustment, replace the packing and then adjust as above.

B. Steering

The manufacturer's instructions for maintaining pedestal steering system should be followed closely. Wires should be periodically inspected for proper tension. Lightly oil all wire.

C. Electrical Systems

The electrical system is a 12-volt, negative ground installation. The owner should periodically inspect battery(ies) and cables for signs of corrosion, cracks, and electrolyte leakage.

D. Plumbing Systems

All pumps should be checked frequently to insure proper operation. This

is an especially important regular maintenance item since proper functioning of a pump could save your vessel from serious damage in the future.

Inspect all hoses for chafing and dry rot. See that hose clamps are tight. Check that the pump impeller area is clean and free of obstructions.

Inspect electrical wiring for corrosion. Make sure float switches move freely and are making an electrical connection.

The owner should become familiar with the layout of the water and waste systems by walking through the boat with the diagrams provided in this manual. It is especially important that the owner knows all thru-hull valve locations and inspects for leaks frequently.

General Thru-hull List (*varies from boat to boat—see diagrams in section VI*)

- 1) Engine cooling system
- 2) Galley sink
- 3) Head sink
- 4) Head toilet (water intake)
- 5) Holding tank discharge
- 6) Scupper drains

E. Fuel System

The owner should inspect the condition of fuel lines for cracks or leaks. A primary source of fuel-related problems is water in the system. The owner should seek out only well maintained fueling facilities and make sure fuel fillers are tightly secured after filling. Check and maintain fuel filters periodically.

F. General Care

CLEANING FIBERGLASS SURFACES:

Fiberglass surfaces should be cleaned regularly. Normal accumulations of surface dirt can be removed simply by occasional rinsings with water. If your boat is operated in salt water, more frequent rinsing will be required. To remove stubborn dirt, grease or oil, use a mild detergent and a soft brush. Rinse with clean fresh water.

It is also a good idea to wax the fiberglass once or twice a year to maintain a deep, glossy appearance. Your local marine supply should be able to provide an appropriate wax.

FIBERGLASS REPAIRS:

Your Hunter or Legend dealer can supply you with the proper gel coat used to repair any hairline cracks or chips.

1. Using a mild detergent solution, clean repair area completely of wax, dirt or oil, and dry completely.
2. To patch "spiderweb" or hairline cracks, begin by widening the crack so that it will hold putty. This is most easily done with an electric drill or router equipped with a V-shaped grinding bit. Also, cut one-quarter inch or so beyond the end of each crack to relieve any stress.
3. Brush away all dust from the crack.
4. Mix gel coat with filler powder to form a creamy consistency. Mix more than enough patching compound to do the job and stir to a smooth blend.

for application.

5. Using a putty knife, work the mixture firmly into the crack to eliminate air bubbles. Leave an excess of about one-sixteenth of an inch above the surface of the crack to allow for shrinkage. Wet sand and buff (with compound) the repaired area.

TEAK CARE:

Teak wood is an extremely durable wood with a high oil content. To maintain that durable quality it should be given a coat of teak oil once a year or more in northern climates and twice a year or more in tropical climates.

Teak can be allowed to weather out, as seen on many boats, but this will eventually lead to cracking and splitting.

If you wish to maintain your teak with varnish, resin or urethane, a sealer should be applied after cleaning and sanding. Complete finishing procedures can be obtained from your marine finish products manufacturer or supplier.

FABRIC CARE:

Cushions should be removed and stored at home if possible. If not, prop them vertically to promote airflow around each cushion.

WINCH MAINTENANCE:

Follow the maintenance instructions prescribed by the winch manufacturer.

GENERAL HARDWARE MAINTENANCE:

Check all fittings regularly to be sure screws are tight. Occasionally lubricate all moving parts on such fittings as blocks, turnbuckles and cam cleats, as well as the locking pins of snatch blocks, track slides, spinnaker poles, etc.

Inspect chocks, cleats and fairleads for roughness and smooth with fine-grained emery paper if necessary.

Also, replace any missing or damaged cotter pins in turnbuckles and shackles, and either tape them or use protective covers manufactured for that purpose.

V. Storage/Winterization

IMPORTANT: Winter storage is recommended to be done in one of the following three ways, either: 1) by blocking the boat via a cradle; or 2) with chained stands on level ground; or 3) by storing the boat in the water with a bubbler system to prevent icing. Damage to your boat, including engine misalignment caused by twisting, is not covered by the warranty.

A. Sails

Sails and synthetic lines should be washed and dried thoroughly. Sails should be properly folded and stowed in a dry, well ventilated place. Many sailboat owners send their sails back to the sail manufacturer at the end of each season. The sailmaker will check the stitching and sailcloth for wear and store the sails until the start of the next season.

B. Electrical

Remove battery from boat. (Refer to Engine Manual.)

C. Cushions

Cushions should be removed and stored at home if possible. If not, prop them vertically to promote airflow around each cushion.

D. Hatches

Hatches and floorboards should be left open a crack to provide ventilation for the whole boat. However, it is prudent to loosely cover any open hatches with a tarp or plastic sheeting.

E. Water System—Water Heater

WATER SYSTEM:

Open a faucet and allow the pump to empty the tank. Then add approximately two gallons of *non-toxic* anti-freeze solution to the tank and repeat the pumping out procedure.

A second method is to disconnect the hoses at the pump, allowing them to drain. Find the lowest point in the system and disconnect the fitting. Open all faucets to allow the lines to drain. If possible, use a short piece of hose on the faucet to blow through the lines to clear all water.

WATER HEATER:

Open valve and drain fully. Leave valve open during lay-up time.

F. Toilet and Holding Tank

Drain and flush toilet. Using automotive anti-freeze (ethyleneglycol) in a 50/50 mixture with water, pump through toilet and into holding tank.

G. Engine

1. Drain the cooling water completely out of the engine and flush the line thoroughly with freshwater. Don't use high pressure through the line.
2. Remove the fuel completely from all fuel lines.
3. Disconnect the main battery cables from the battery terminals.
4. To prevent corrosion inside the cylinders, pour a little lubricating oil into the suction pipe while turning the engine. Enough oil to reach the intake/exhaust valve is sufficient.
5. Put the piston at top dead center of compression stroke so that the intake/exhaust valves are completely closed.
6. Apply a thin anti-corrosion treatment to the plating and exposed painted surfaces.
7. The engine should be in a well ventilated area, and protected from any kind of dampness.
8. Put a dust cover over the engine.
9. Check your operation manual for engine diagram and for "Manufacturer's Recommended Winterizing Procedures."

H. Outboard Engine

1. Take it home and store it in a safe place. Be *very careful* storing the gas tank as the gasoline is very flammable.

STORAGE/WINTERIZATION

IMPORTANT: Winter storage is recommended to be done in one of the following three ways: 1) by blocking the boat via a cradle; or 2) with chained stands on level ground; or 3) by storing the boat in the water with a bubbler system to prevent icing. Damage to your boat, including engine damage caused by twisting, is not covered by the warranty.

SAILS

Sails should be properly folded and stowed in a dry, well ventilated place. Many sailmakers will return their sails back to the sail manufacturer at the end of each season. The sailmaker will check the sails and sailcloth for wear and store the sails until the start of the next season.

ELECTRICAL

Remove battery from boat. (Refer to Engine Manual.) and charge. It is a good idea to store the electronics (Radio, Radar, etc.) and store in a safe place.

CUSHIONS

Cushions should be removed and stored at home if possible. If not, prop them vertically to allow airflow around each cushion. *Dry Clean Only!*

HATCHES

Tenting the deck during storage will help prevent ice from forming and damaging deck fittings. The installation of a passive vent will help with ventilation while the boat is stored.

WATER SYSTEM - WATER HEATER

WATER SYSTEM:

Open a faucet and allow the pump to empty the tank. Then add approximately two gallons of anti-freeze solution to the tank and repeat the pumping out procedure.

A second method is to disconnect the hoses at the pump, allowing them to drain. Flush the system and disconnect the fitting. Open all faucets to allow the lines to drain. Attach a short piece of hose on the faucet to blow through the lines to clear all water. A dash of baking soda will help freshen the system.

WATER HEATER:

Open valve and drain fully. Leave valve open during lay-up time.

TOILET AND HOLDING TANK

Drain and flush toilet. Using automotive anti-freeze (ethyleneglycol) in a 50/50 mix, pump through toilet and into holding tank. Refer to Galley/Head section for instructions.

Hunter

TYPICAL KEEL INSTALLATION

