

## Marine VHF Radio Channels

16	Emergency - Distress
----	----------------------

13	Interhip - Safety
5	HSC - Traffic

9	Boater Calling
68	Recreational
69	Recreational
71	Recreational
78A	Recreational

03A	Reserved for Coast Guard
21A	Reserved for Coast Guard
22A	Reserved for Coast Guard
81A	Reserved for Coast Guard

**IF LIFE AT RISK or IMMINENT BOAT DANGER  
MAYDAY - MAYDAY - MAYDAY**

"This is sailing vessel \_\_\_\_\_ transmitting  
on channel 1 - 6 requesting assistance - OVER"  
**(wait for response for 30 seconds before retry)**

Explain to USCG type of problem **BRIEFLY**. Add:

- \* Boat Description: 30 foot sailing sloop white hull, etc.
- \* Number of People on Board (POBs)
- \* Estimated position

**IF IT IS A SERIOUS SAFETY WARNING**

**PAN-PAN PAN-PAN PAN-PAN**

**HAZARD TO NAVIGATION**

**SECURITAY - SECURITAY - SECURITAY**

# STATE OF CHARGE FOR 12V LEAD ACID / DEEP DISCHARGE MARINE BATTERIES

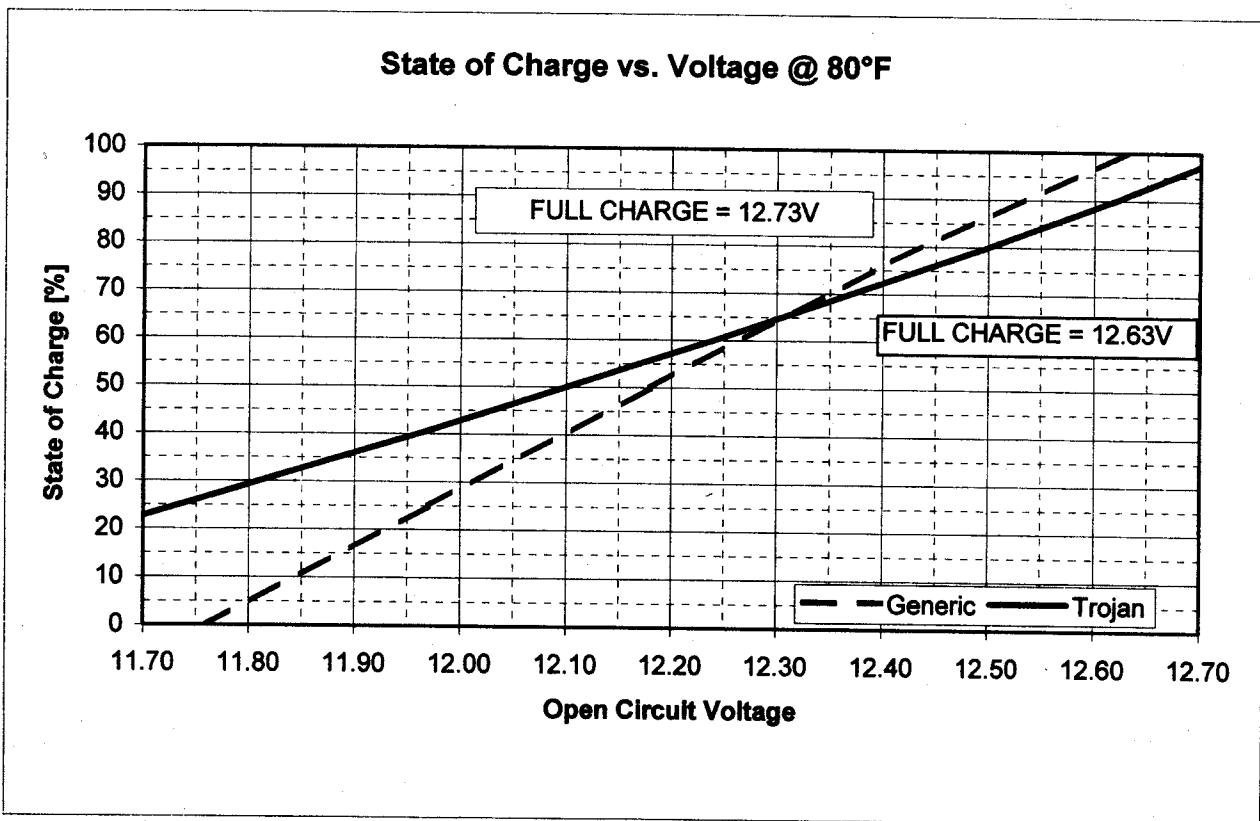
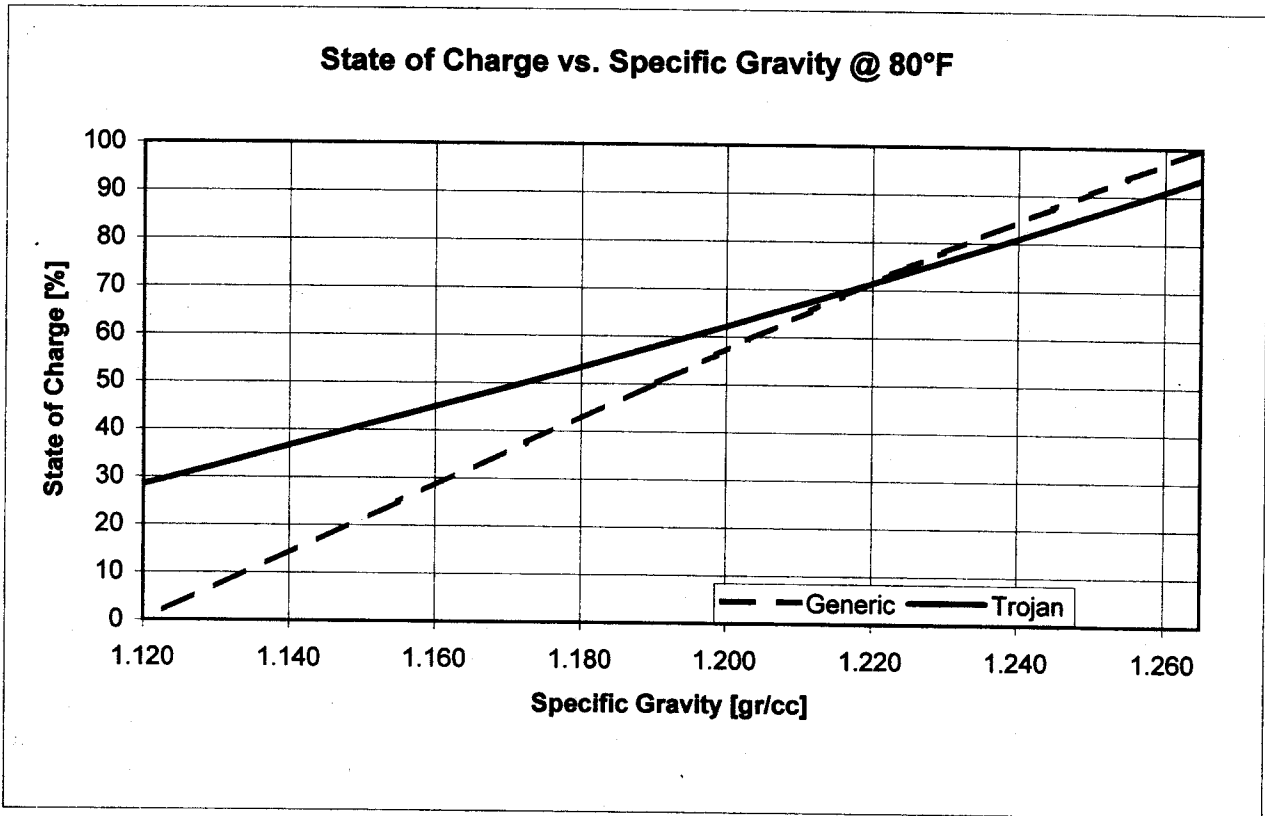

**Battery Capacity vs. Discharge Rate  
for a 100 Amp/hour Battery**

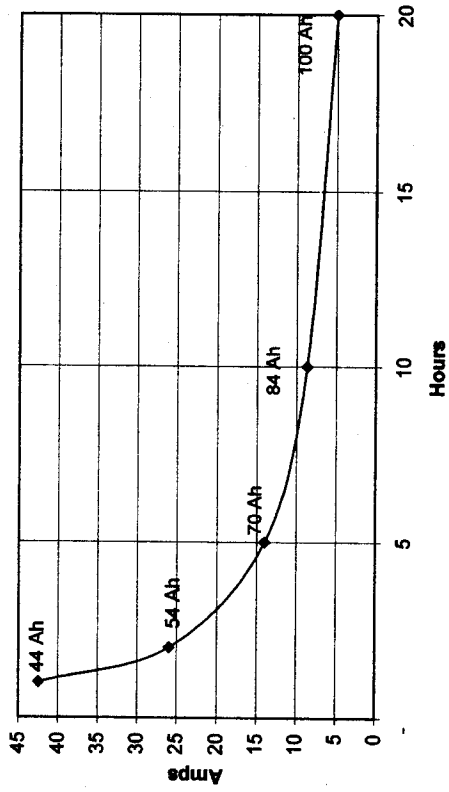

**State of Charge vs. Voltage**

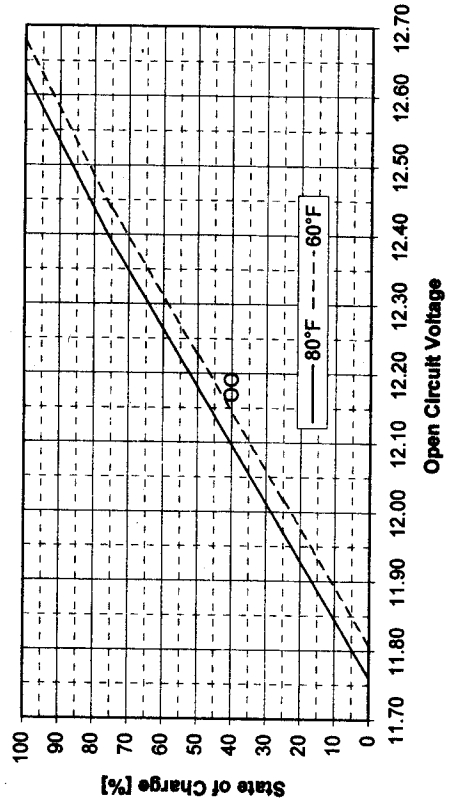

**Life Cycles vs. Discharge**

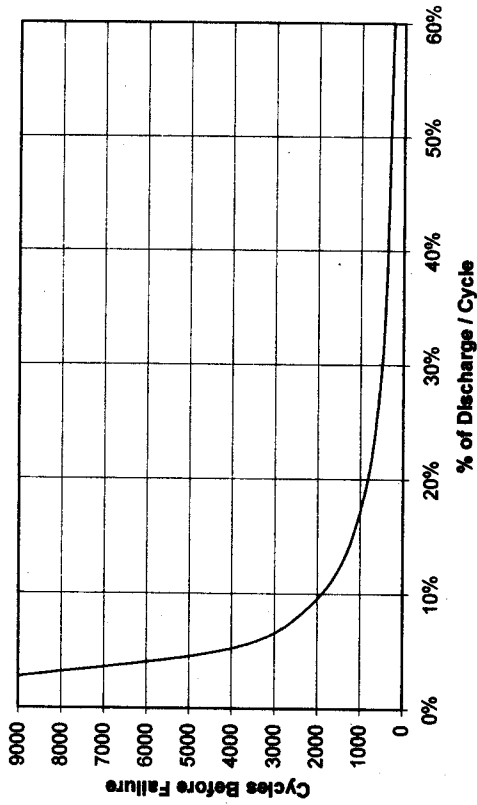

**State of Charge vs. Specific Gravity**

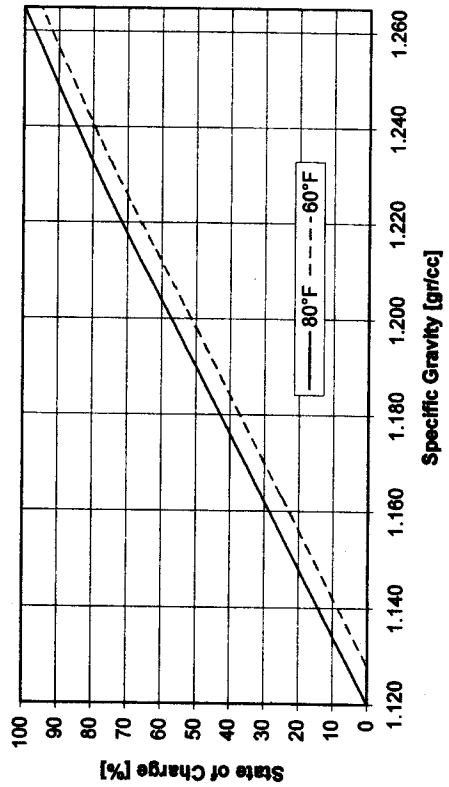

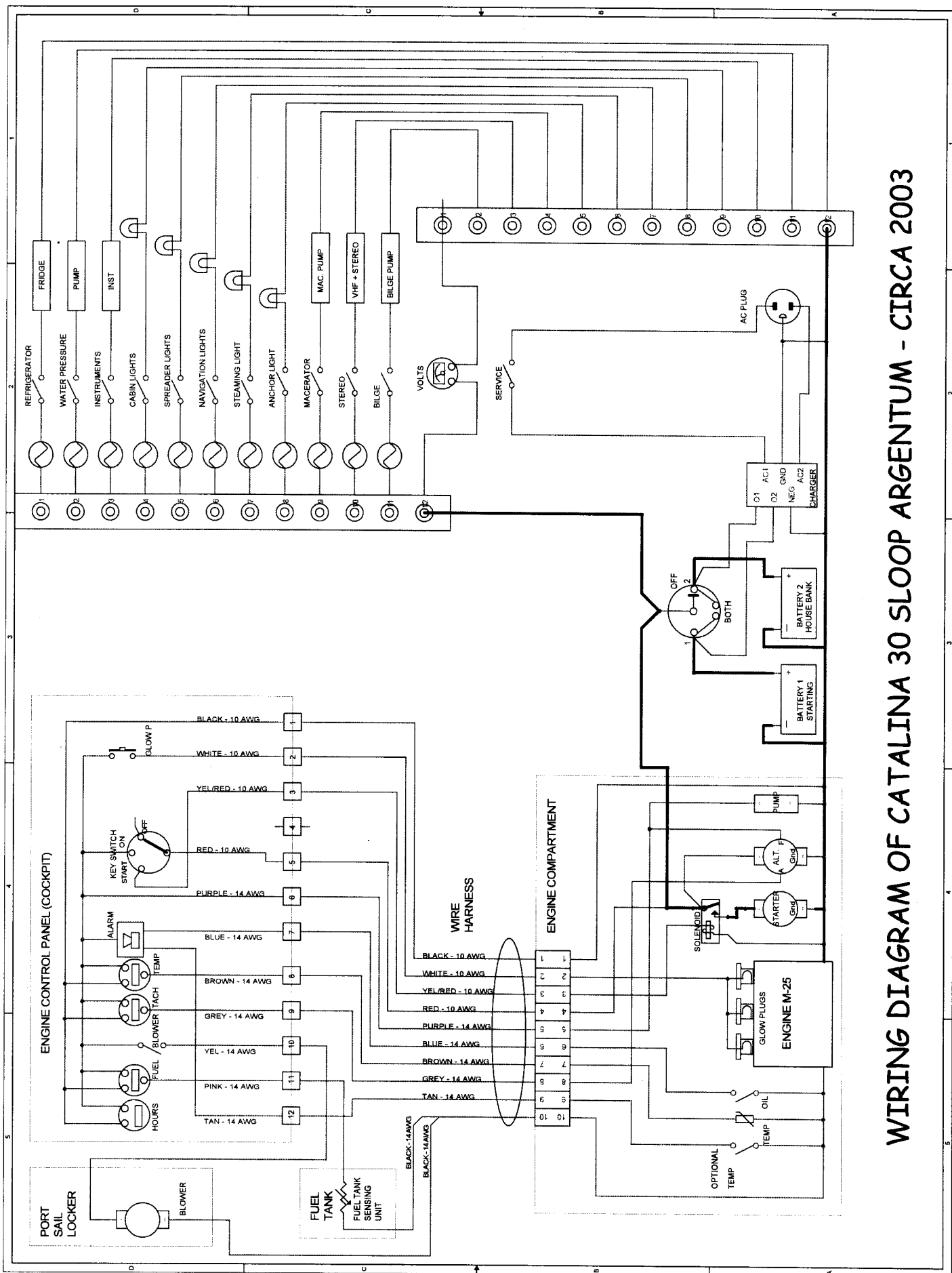

WIRING DIAGRAM OF CATALINA 30 SLOOP ARGENTUM - CIRCA 2003

# COMMON MARINE BATTERY CONNECTIONS

