

# OCEANIS 43

## Owner's Manual



**BENETEAU**



Code: 123063

# Welcome aboard

Madam, Sir,

You have just taken delivery of your new BENETEAU boat and we thank you for the confidence you have shown us in ordering a vessel of our brand. The whole BENETEAU team welcomes you aboard.

A BENETEAU is made to last, in order to bring you all the pleasure you expect from a vessel over a period of many years each boat is subject to the utmost attention to detail from the design stage right through to launching.

This manual was meant to help you to enjoy your boat comfortably and safely. It includes the boat specifications, the equipment provided or installed, the systems and tips on her operation and maintenance. Some of the equipment described in this manual may be optional.

Your BENETEAU dealer will be able to help and advise you in the use and maintenance of your boat.

**Read this user's guide/owner's manual carefully and get to know your boat before using it.**

**The better you know your vessel the more pleasure you will get from being at the helm.**

The sea is a source for learning. Caution based on a knowledge of one's own limits and those of the boat is the pre-requisite for an accomplished sailor.

Even when your boat has been adapted for them, the sea and wind conditions corresponding to the design categories A, B, C and D may vary, ranging from severe conditions to strong storms subject to the risks of exceptional waves and gusts of wind, this meaning they are dangerous conditions in which only an experienced, fit and well trained crew manoeuvring a well maintained boat can sail in a satisfactory manner.

This user's guide/owner's manual is not a course in safety at sea or about sailing sense. If this is your first boat or if you change to a new type of boat which you are not used to, get some training in boat control and sailing to ensure your safety and comfort. Your dealer, your international sailing association or your yacht club will be very happy to recommend local sailing schools or professional instructors.

**Make sure the sea and wind conditions will correspond to the category of your boat and you and your crew are able to handle the boat in these conditions.**

**Always listen to the weather forecast before you put out to sea.**

Keep this user's guide/owner's manual in a safe place and hand it over to the new owner if you sell your boat.

You are advised to keep all the instructions and manuals provided by the boat equipment manufacturers (accessories...) in the same place as this manual



BENETEAU



# Introduction

---

## The users of the boat are informed of the following:

■ This user guide/owner's manual is not a maintenance or repair guide. In case of difficulty do not hesitate to call on the services of your concessionaire BENETEAU.

■ Any alterations which may affect the safety specifications of the boat must be assessed, carried out and recorded by persons qualified to do so. Any change in the distribution of the vessel's mass (adding a radar, altering the mast, changing an engine, etc) may affect the stability, trim and performance of your boat.

The BENETEAU shipyards may not be held responsible for any alterations which they have not approved.

■ The complete crew must be equipped appropriately.

■ In numerous countries, a licence, an authorization or a training course is requested. Make sure you have this legal authorization before you use your boat.

■ Adapt the use of your boat to her condition that wears out with time and use.

■ Any boat, however solid she may be, may be severely damaged if badly used. This is not compatible with a secure navigation. Always adapt the speed and direction of your boat to the conditions of the sea.

■ The boat shall not be loaded more with than the maximum load recommended by the builder, in particular the total weight of the food supplies, of the different equipment that are not supplied by the builder and of the persons on board.

■ The weight of the boat shall be properly distributed.

■ The stability is reduced when you add weight in the upper parts.

■ In case of heavy weather, the hatches, lockers and doors shall be closed in order to minimize the risk of water coming in.

■ Breakers are serious dangers to stability.

■ The water in the bilge shall be kept at its minimum.

■ The stability may be reduced when you tow a boat or when you lift heavy weights with the davits or the boom.

■ If your boat is equipped with a liferaft, carefully read the instructions. The boat must have on board all the proper safety equipment (lifejackets, buoys, harness, flares, liferafts, etc.) depending on the type of vessel, its certification, the country, the weather conditions encountered, etc.

■ The crew must be familiar with the use of all the safety equipment and the emergency safety procedures (MOB, towing etc.). Sailing schools organise regular training sessions.

■ Anyone on the deck shall wear a life jacket or a buoyancy aid.

The safety regulations as defined by the sailing code and enforced by the "COLREG" should be observed.

# Introduction

## **Name plate:**

A part of the data is shown on the builder's plate fixed to the boat. The explanation of these data is given in the appropriate chapters of this manual.

## **Identification of vessel:**

The vessel's identification is found on the builder's certificate delivered with the boat and is engraved on the starboard aft side.

So as to be able to continuously improve their product the BENETEAU shipyards reserve the right to make any alterations in design, layout or equipment which they judge necessary.

That is the reason why the specifications and information given are not contractual, they may be modified without prior notice or updates.

This owner's manual is designed in accordance with the ISO 10240 standard requirements, it has a general purpose and it may sometimes list some equipment or accessories or deal with some points or questions that are not relevant to your own boat.

The different warnings used throughout this guide are broken down as follows.



## **DANGER**

Indicates the existence of a serious inherent danger with a high risk of death or serious injury if the appropriate precautions are not taken



## **WARNING**

Indicates the existence of a danger which could lead to injury or death if the appropriate precautions are not taken



## **PRECAUTION**

Indicates a reminder of safety practice or draws attention to dangerous practices which could cause injury to persons or damage to the vessel or to its components



## **PIECE OF ADVICE - RECOMMENDATION**

Indicates a recommendation or advice for carrying out actions or manoeuvres which are appropriate to the intended result

**HISTORY OF UPDATES**

•Index A..... 01/2010





# Contents

---

.....	Introduction	
7.....	General specifications	1
13 .....	Safety	2
31 .....	Hull	3
35 .....	Deck	4
47 .....	Steering system	5
51 .....	Rigging and Sails	6
65 .....	Interior	7
71 .....	Water and sewage water	8
85 .....	Electrical equipment	9
103 .....	Engine	10
117.....	Launching	11
121 .....	Winter Storage	12
.....	Personal notes	

---





## General specifications

- Technical specifications
- Certification
- Design category
- Your boat

## ■ TECHNICAL SPECIFICATIONS OCEANIS 43

L.O.A.....	13,10 m
Hull length.....	12,75 m
L.W.L.....	11,93 m
Overall width.....	4,12 m
Beam.....	4,12 m
Waterline beam.....	3,62 m
Air draught - Empty vessel.....	18,30 m
Draught - Deep draught keel.....	2,00 m
Ballast weight deep draught.....	2 480 kg
Draught - Shallow draught keel.....	1,65 m
Ballast weight shallow draught.....	2 770 kg
Light displacement.....	8 875 kg
Displacement with maximum load.....	11 460 kg
Maximum load recommended by the builder.....	2 585 kg
Including the mass of the persons who are authorized on board (75 kg/165 lbs per adult), the supplies, the liquids that can be used (fresh water and fuel) in fixed completely full tanks, the additional loads, the optional equipments, the liferaft and the scope for load.	
Recommended maximum power.....	60 kW
Total mass of liquids (all tanks full).....	739 kg
Freshwater capacity.....	1 60 l + 200 l
Sewage water capacity (in each bathroom).....	73 l
Fuel oil tank capacity.....	200 l
Refrigeration unit capacity.....	170 l
Battery capacity - Service.....	2 x 140A
Spare batteries - Service.....	140A

Battery capacity - Engine.....	110 Ah
Battery capacity - Bow thruster.....	2 x 50 Ah
Cabins.....	2/3/4
Berth.....	4/6/8/10
Build material:.....	Laminated polyester
Architect.....	BERRET - RACOUPEAU
Interior design.....	NAUTA Design

*NOTE: The capacities indicated are maximum (including options).*



# General specifications 1

## CERTIFICATION

CE Category	Persons Maximum
A	10 persons
B	11 persons
C	12 persons
D	12 persons

## DEFINITION OF DESIGN CATEGORIES

Design category	Wind force (Beaufort scale)	Significant height of waves to be considered (in metres H 1/3)
Vessel designed for navigation:		
A - "At high sea"	Over 8	Over 4
B - "In open sea"	Upto and including 8	Upto and including 4
C - "Near to the coast"	Upto and including 6	Upto and including 2
D - "In sheltered waters"	Upto and including 4	Upto and including 0,3

The OCEANIS 43 model conforms to the directive 2003/44/CE

### SAILS - CLASSICAL MAST

Classical mainsail	39,05 m <sup>2</sup>
Genoa	43,51 m <sup>2</sup>
Symmetric spi	125,00 m <sup>2</sup>
Asymmetric spinnaker	110,00 m <sup>2</sup>
I	15,77 m
J	4,67 m
P	14,46 m
E	4,80 m

### SAILS - IN-MAST ROLLER FURLER

Furling mainsail	35,67 m <sup>2</sup>
Genoa	43,51 m <sup>2</sup>
Symmetric spi	125,00 m <sup>2</sup>
I	15,77 m
J	4,67 m
P	14,26 m
E	4,80 m

The sails are the main propulsion means of the OCEANIS 43.

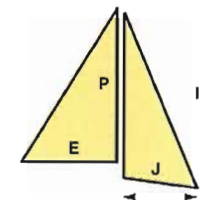

### **CATEGORY A**

This boat is designed for sailing in winds that may exceed force 8 on the Beaufort scale and in waves of a significant height of 4 and more, and the boat is to a large extent self-sufficient. Unusual conditions such as hurricanes are excluded.

You may meet with such conditions when you sail long crossings, for instance across the oceans, or close to the shore, when you are not protected from the wind or waves over several hundreds of nautical miles.

### **CATEGORY B**

This boat is designed for sailing in winds that may exceed force 8 on the Beaufort scale and in waves of a significant height of 4m or less.

You may meet with such conditions when you sail on the open sea or close to the shore, when you are not protected from the wind or waves over several hundreds of nautical miles. You may also meet with these conditions on an inland sea with a size sufficient to generate the wave height in question.

### **CATEGORY C**

This boat is designed for sailing in winds that may exceed force 6 on the Beaufort scale and in waves of a significant height of 2m or less.

You may meet with such conditions in exposed inland waters, in estuaries and in coastal waters with moderate weather conditions.

### **CATEGORY D**

This boat is designed for sailing in winds not exceeding force 4 on the Beaufort scale and in waves of a corresponding height (significant height of 0,5m or less).

You may meet such conditions in protected inland waters and in coastal waters when the weather is fine.

*Note:*

*The significant height of a wave is the average height of the upper third of the waves, that approximately corresponds to the height of a wave an experienced observer can assess. Some waves will be twice as high as this value.*

# Your boat

Name of the owner: .....

Name of the boat: .....

Address: .....

Delivery date: .....

.....

Registration number: .....

Telephone: .....

Serial number (C.I.N): .....

email: .....

Entrance door key n°: .....

**Telephone N° / Address to be contacted in case of emergency**

Engine type		
Serial number		
Engine key number		







## Safety

- Safety Equipment
- General information
- Gas system
- Recommendations for gas
- Fight against fire
- Bilge pump system
- Emergency tiller

**SAFETY EQUIPMENT**



REF	Designation
1	Position of swimming ladder (means of coming back onboard)
2	Location of liferaft locker



Fastener - Swimming ladder



Swimming ladder  
(means of coming back onboard)



Storage locker for liferaft  
(not supplied)

## ■ GENERAL INFORMATION

### DANGERS

The major hazards concern:

- The gas system.
- The electrical system.
- Manoeuvring the vessel and the sails.
- The motorisation.

**Please refer to the relevant paragraphs.**



### DANGER

- Fuel leaks or vapour represent a danger of fire and explosion.
- Leave the engine compartment ventilated for a long time before starting the engine.
- There may be danger of fire or explosion if direct or alternating current systems are incorrectly used. Refer to chapter Electricity.



### WARNING

- Before you sail, list the compulsory safety equipment.
- Don't exceed the number of persons indicated in the chapter 'Specifications'.
- The total weight of the persons and equipment must never exceed the maximum load recommended by the manufacturer.
- Use the seats provided.



### PIECE OF ADVICE - RECOMMENDATION



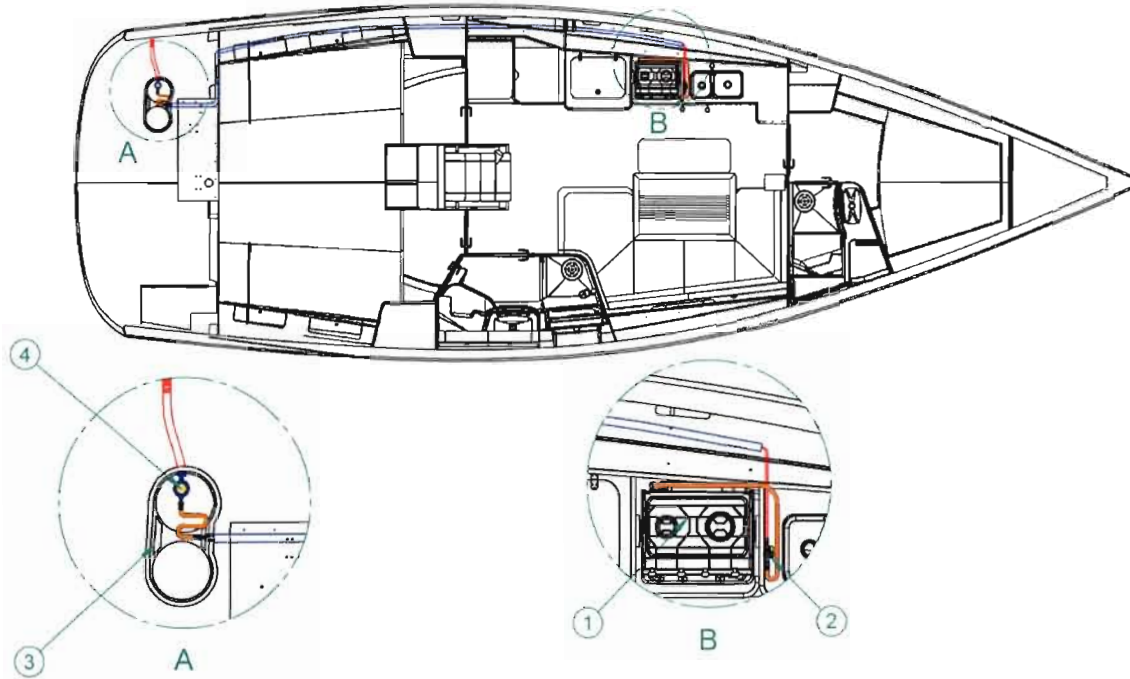

- When sailing, never padlock or lock the liferaft locker.
- Before you sail to sea, carefully read the instructions indicated on the liferaft to launch it.
- Close the deck hatches and fore portholes each time before each trip (including the companionway hatch in heavy weather).
- Don't store anything below the floorboards.
- Be careful to fasten all movable elements when the vessel is underway.

# ■ GAS SYSTEM

## LAY OUT OF

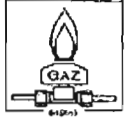

REF	Designation
1	Cooker - Oven
2	Valve - Under cooker
3	Gas cylinder locker
4	Regulator valve

  <p>A diagram enables it to be found easily</p> <p><b>Supply valve - Gas</b></p>	 <p><b>7</b></p> <p><b>Valve</b></p> <p>6 - Open position 7 - Closed position</p>	  <p><b>Gas cylinder locker</b></p>
--	---	---

## RECOMMENDATIONS FOR GAS

Type of cylinder: butane, service pressure 10 kg/cm<sup>2</sup> or according to current standards of your country).

Close the valves on the system and on the cylinder when the appliances are not used. Close the valves before you change cylinders and immediately in case of emergency.

Never leave unattended an appliance that is working. Don't install or store flammable materials above or over the stove (curtains, papers, napkins etc.).

Make sure that the valves of the appliances are closed before you open the cylinder or hose valve.

In case you smell gas or find that the burners have gone out (although appliance models cut off automatically if the flames go out), turn off the valves of the appliances. Do ventilate the boat in order to get rid of any residual gas. Find the cause of the problem.

Regularly test the gas system in order to detect any gas leak.

Check all the connections using water and soap or detergent, closing the valves of the appliances and opening the valve on the cylinder.

If you detect a leak, close the valve of the cylinder and repair before you use it again.

The appliances use the oxygen of the cabin and release combustible gases. Ventilate your boat when using appliances.

Don't obstruct the air vents and at least leave the door open. Don't use the oven or stove as back up heaters.

Lock the stove oven when being not used in order to avoid damaging the tubes when sailing.

Never obstruct the fast access to the components of the gas system. Keep the taps of the empty cylinders turned off and the cylinders disconnected.

Keep the protection, lids, covers and taps in their places.

Don't use the gas cylinder storage place to store other equipment. Only use the proper locker to store the gas cylinders.

Regularly check and replace the rubber tubings that link the cylinder to one end of the circuit and the stove to the other one, depending on the norms and regulations in force in your country.



### WARNING

- Don't use a solution containing ammonia.
- Don't use a flame to detect leaks.
- Don't smoke, don't use a naked flame when you change the gas cylinder.



### WARNING

- Do not use a solution containing ammonia to detect leaks.
- Don't use a flame to detect leaks.
- Don't smoke, don't use a naked flame when you change the gas cylinder.



### PIECE OF ADVICE - RECOMMENDATION

- Shut off the gas supply at the bottle as well as the cooker tap.
- When changing the cylinder, refit the cap in place on the regulator threaded section (to avoid corrosion).
- For winter storage instructions and precautions, refer to Chapter 12.



SCHEMA GAS - VERSION EUROPE

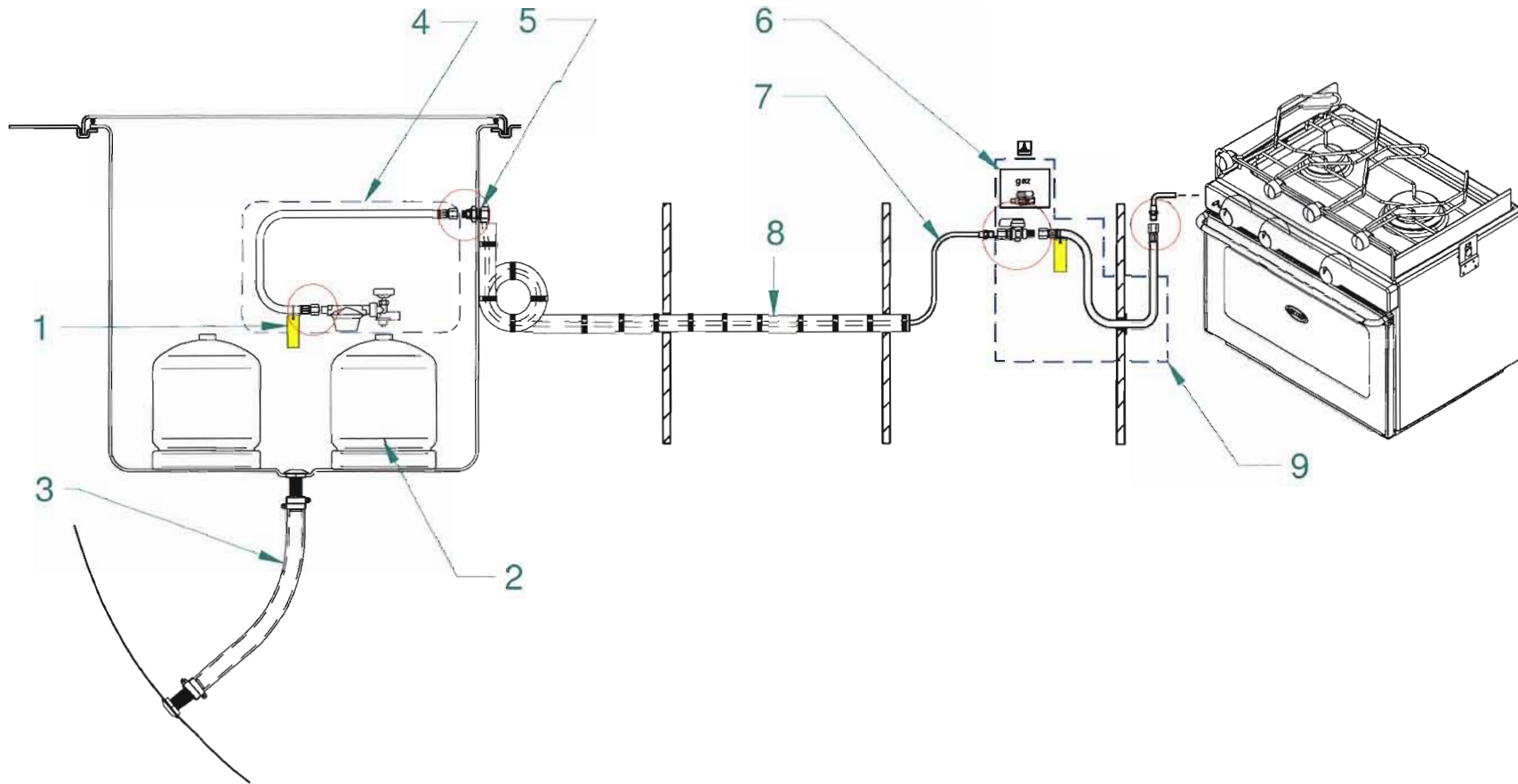

REF	Designation
1	Regulator valve
2	Gas cylinder
3	Drain
4	Connection kit gas bottle
5	Rubber washers
6	Pictogram
7	Connection kit gas copper
8	PVC girdled sleeve
9	Gas appliance connection kit

## Safety 2

Regularly check and replace the rubber tubings that link the cylinder to one end of the circuit and the stove to the other one, depending on the norms and regulations in force in your country.

Pay particular attention to keep in good condition the screw thread of the cylinder on which the regulator is. Check the condition of the regulator every year and change it if necessary. Use regulators identical to the ones that are fitted.

Have the repairs carried out by someone skilled.

### POSITION OF GAS BOTTLE

The locker for storing gas bottles can be reached through the cockpit. The locker can accommodate 2 gas bottles. The locker is equipped with bottle fastening straps.

### FIGHT AGAINST FIRE.

It is the owner's or the skipper's responsibility:

- To have the extinguishers checked in pursuance of the instructions given.
- Use extinguisher replacements with equivalent features (same capacity and fire resistance) if the ones in place are out of date or have been used.
- To tell the crew:
  - where the extinguishers are and how they work,
  - where the release aperture is situated in the engine compartment,
  - where the emergency exits are.
- Make sure the extinguishers can be reached easily when people are on board.
- Make sure that the ventilation openings in the engine (and generator, if installed) compartment are well cleared.

Keep the bilge clean. Regularly check that there is no fuel or gas vapour.

For protection of the deck, the vessel owner/user should provide at least one fire bucket complete with rope in an immediately accessible position.

Do not store combustible materials in the engine compartment.

If non-combustible materials are stored in the engine compartment they must be secured so there is no danger of them falling on machinery and they do not obstruct access to and from the compartment.

**Always fasten the curtains open when the gas cooker is working.**

Exits other than the doors and hatches of the main companionway, equipped with permanently fitted ladders, are identified with a symbol.



### WARNING

- Keep an extinguisher handy in case the fire should start again.
- Fire fighting equipment (portable extinguishers, fire blankets and buckets) must be permanently and immediately accessible.



SCHEMA GAS - VERSION US

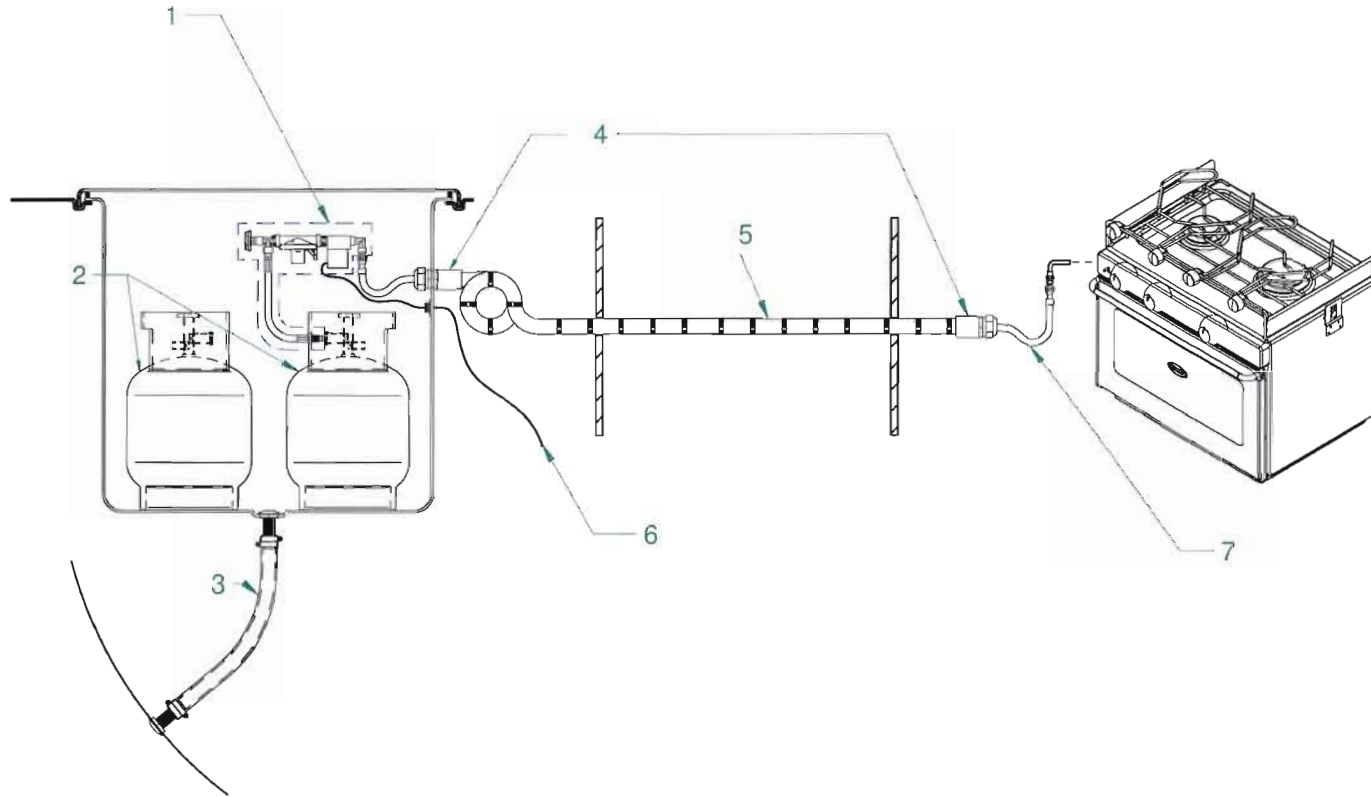

REF	Designation
1	Regulator valve 12V
2	Gas cylinder
3	Drain
4	Stuffing box
5	PVC girdled sleeve
6	Electromagnetic valve for gas 12V
7	Pipe Propane Plastic

# Safety 2

## EMERGENCY EVACUATION AND LOCATION OF EXTINGUISHERS

Version 2 cabin



Version 3/4 cabin

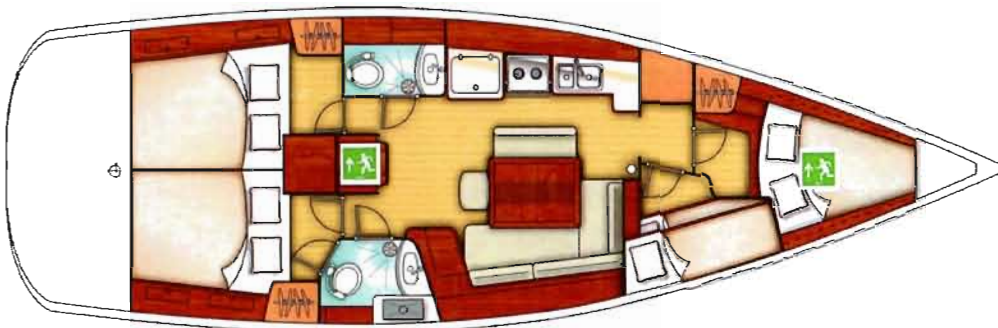

Emergency exits in case of fire

- Deck hatch of the fore cabin
- Companionway





Position of portable extinguishers (not supplied)

- Cockpit locker



**Version 2 cabin**

- Galley
- Starboard saloon



**Version 3 cabin**

- Hanging locker - Aft cabin - To port
- Galley



**Version 4 cabin / Charter**

- Hanging locker - Aft cabin - To port
- Galley

*NOTE: Same position for the other layouts.*

## EXTINGUISHERS

The extinguishers are part of the compulsory equipment.

An extinguisher or a fire blanket shall be set less than 2 m from any flame appliance.

Extinguishers must be placed less than 5 m from any berth.

It is compulsory for an extinguisher to be placed less than 2 m away from the extinguisher aperture of the engine compartment.

An extinguisher shall be less than 1 m from the steering station.

The extinguishers must be in position (see "Extinguisher positions" diagram).

Extinguisher, per unit, minimum capacity 5A/34B.

For the OCEANIS 43: 15A/102B (equivalent 3 extinguishers of this minimum capacity).



### DANGER

-There may be danger of fire or explosion if direct or alternating current systems are incorrectly used (Refer to chapter Electricity).



### WARNING

- Do not obstruct the ways to the emergency exits.
- Do not obstruct the safety controls (fuel oil valves, gas valves, power switches).
- Do not block the extinguishers placed on shelves.
- Do not leave the vessel unattended when a cooker or heater is in use.
- Do not use gas lamps in the vessel.
- Do not alter the vessel systems (electrical, gas or fuel).
- Do not fill up a tank or change a gas cylinder when an engine is running or a cooker or heater is on.
- Do not smoke while handling fuels or gas.



### WARNING

- The **CO<sup>2</sup>** extinguishers shall be used only to fight **electrical fires**.
- Clear the area immediately after use in order to avoid suffocation.
- Air before entering.



POSITION OF FUEL VALVE AND ENGINE COMPARTMENT EXTINGUISHER APERTURE



Extinguisher hole located under the companionway step

A diagram enables it to be found easily



Supply valve Fuel

## Safety 2

The engine compartment has an aperture that makes it possible to inject the extinguishing product inside without opening the usual access hatches.

### **INSTRUCTIONS TO FOLLOW IN CASE OF A FIRE IN THE ENGINE COMPARTMENT BILGE:**

- Stop the engine.
- Switch off power and stop fuel supply.
- Block off the air supply from the air inlets and outlets of the engine.
- Inject the extinguishing product through the aperture.
- Wait.
- Open the access hatches and repair.

## USE OF THE MANUAL BILGE PUMP



Lay out of

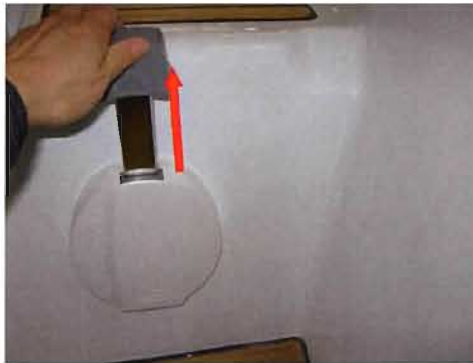

Operation

Capacity: 40,5 liter / minute



## **BILGE PUMP SYSTEM**

### **PROCEDURE TO BE FOLLOWED**

- Switch on power to the electric bilge pumps.
- If necessary activate the manual pump.
- Identify the source of the leak by tasting the water and decide on the relevant action to be taken:
  - freshwater = watertank leak.
  - seawater = breach of hull.

### **ELECTRIC BILGE PUMP**

The first electric bilge pump is located in the sump well.

The electric bilge pump is located on the plumbing board.



Electric bilge pump  
Lay out of: Sump  
Capacity: 70 liter / minute



Capacity: 15 liter / minute

#### **Operation:**

The electric bilge pumps are connected to the 12V service circuit. To enable operation the 12V circuit must be activated by turning on the battery switches.

You can energize the electric bilge pump from the electrical panel.

On the electrical panel - three possible positions : OFF / Automatic / Mechanically operated.

In the automatic position each pump is set off automatically by a trip switch located in the sump area or in the bottom of the hull.

### **MANUAL BILGE PUMP**

The manual bilge pump is in the cockpit.

The control arm of the pump shall be kept accessible whatever the circumstances.



### **WARNING**

- The bilge pump system is not designed to provide buoyancy to the boat in case of damage.
- The bilge pump system is designed to drive out the water being either sea spray or leaks but absolutely not the water coming through a hole in the hull, this hole being the result of a damage.
- Do not let the pumps run while dry, this may cause them damage.
- The water in the bilge shall be kept at its minimum.
- Check the functioning of each bilge pump regularly.



### **SAFETY PRECAUTIONS**

- Clean off debris which could block the pump intake points or strainers. If the watertight partitions which seal off the fore and aft points are fitted with valves they must be closed at all times and only opened to drain water into the main bilge.

USE STEERS FRANK OF HELP



Sector access hole

## ■ EMERGENCY TILLER

The emergency tiller is in an aft locker and shall be easy to get to.

To operate the tiller:

- Use a winch handle and unscrew the tiller cover situated at the back of the cockpit.
- Insert the tiller into the rudder stock and make sure it is fully secure in the square.
- If the automatic pilot is connected and is working after the tiller damage, use it.
- Disconnect all apparatus linked to the rudder stock to use the emergency tiller.



### PIECE OF ADVICE - RECOMMENDATION

- The emergency tiller is designed only to sail at a reduced speed in case of a wheel failure.



## Hull

- Maintenance of the Hull
- Carreening

## CARREENING

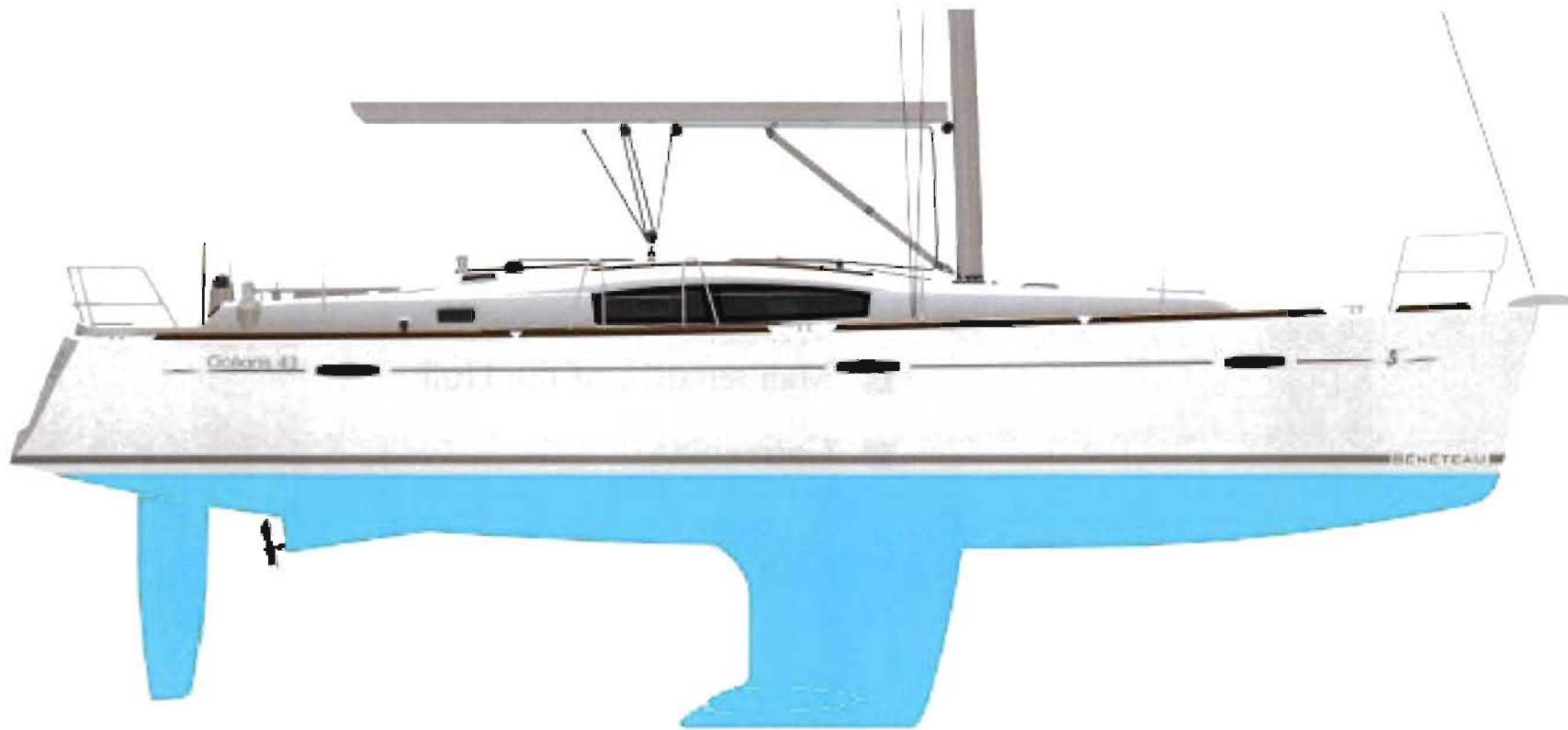

Wetted area : 44 m<sup>2</sup>

## ■ MAINTENANCE OF THE HULL

The materials and equipments of your boat have been selected because of their high quality and performance and ease of maintenance. However you shall carry out a minimum maintenance in order to protect your boat from outside attacks (salt, sun, electrolysis ...).

Preferably wash your boat on shore.

Use as few cleaning agents as possible.

Don't use solvents or aggressive detergent agents. Don't discharge your cleaning product into the water.

## ■ CARREENING

The lower hull of your boat should be covered with an anti-fouling paint which will prevent the adhesion of marine growth.

The nature of the water in which the boat sails will determine the choice of the anti-fouling paint as well as the frequency of hull stripping and painting. Do not hesitate to take advice from your specialists.

Refer to chapter 11 for launching instructions.

### Before applying anti-fouling paint never:

- Do any sanding down.
- Use any other solvents than ethylic alcohol.
- Use detergents under pressure.
- Use scrapers.
- Do any sanding other than a light rubbing down by hand with a grade 400 wet abrasive paper (to roughen up the hull before the first coat).

If cleaning of the anti-fouling paint has to be done with a high pressure hose:

- The water temperature must not exceed 15 °C.
- The water pressure must not exceed 150 bars.
- The distance between the hose nozzle and the hull must not be less than 10 centimetres.

Follow the supplier's instructions very closely when applying the anti-fouling paint.

All these hull maintenance operations can be carried out by your dealer.



### PRECAUTION

- Consult the harbourmaster's office to find out the conditions of use for water and air facilities for cleaning your vessel.
- It is necessary to seek the advice of your concessionaire with regard to gel-coat repairs.



### PRECAUTION

- When applying the anti-fouling paint do not paint over the electronic instrument sensors nor the anodes.



### PIECE OF ADVICE - RECOMMENDATION

- When in dry dock check the anode on the propeller shaft line.
- See "Motorisation" chapter.





## Deck

- Navigation
- Stability
- Prevention of manoverboard
- Mooring
- Towing
- Anchoring
- Maintenance of the Deck

## NAVIGATION - DECK LAYOUT

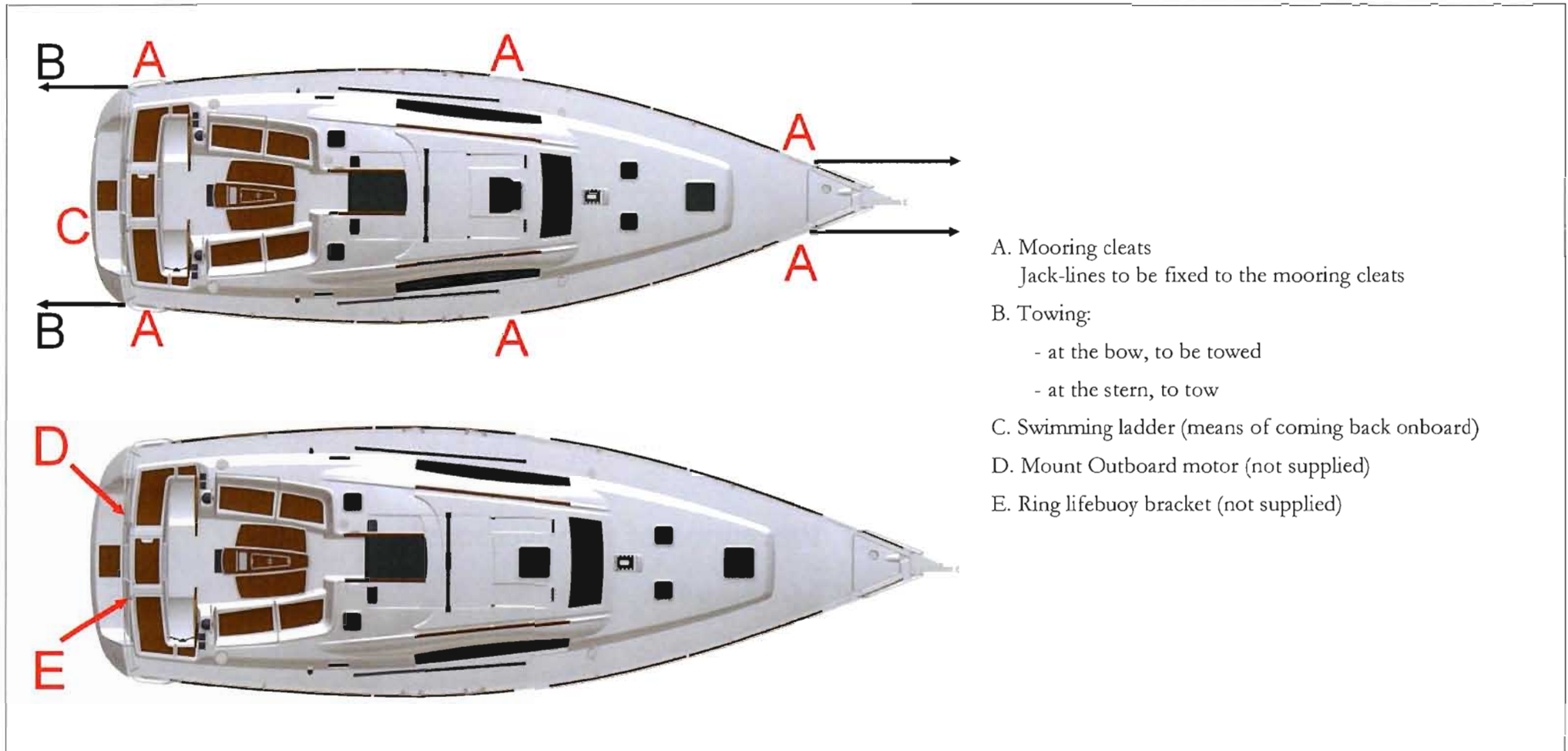

### WARNING

-The maximum weight of the outboard engine (not supplied) on the pushpits should not exceed 20 kg.

## STABILITY

Breaking waves represent a serious danger for stability and for taking in water. Close the companionway doors and hatches in heavy seas.

During sailing keep all the portholes, windows and doors closed.

- The stability is reduced when you add weight in the upper parts.
- Stability may be reduced when towing a boat or when heavy weights are lifted with the davits.

## PREVENTION OF MANOVERBOARD

Regularly check the guard-rails:

- With metal guard-rails, watch for corrosion particularly at connecting points.
- With synthetic guard-rails, change them as soon as they show signs of wear due to chafing or UV.

Areas forbidden when sailing:

- Aft quarterdeck.
- Roof.

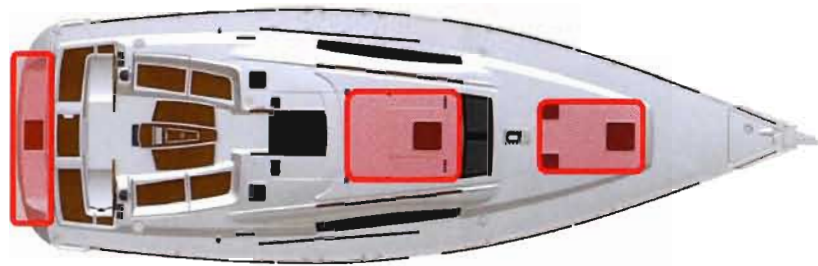

## MOORING

A sufficient number of mooring lines suitably sized and suitable for the environment shall be on board for mooring your boat.

- Always manoeuvre your boat using the engine.
- Make allowance for the current and wind when you handle your boat.
- Protect your boat to the highest degree with suitably sized fenders.
- Always keep the mooring ropes unfouled and stored away.
- Handle your boat at a reduced speed.

## AFTER MOORING

- Protect the mooring lines against chafing with plastic sleeves.
- Make allowance for the variations in tides if need be.



### DANGER

- Wear your life jacket.
- In heavy weather, wear your safety harness and fasten yourself to the boat.
- When at sea close the guardrail doors.
- Do not try to stop the boat using a boat hook or your foot, your hand or any other part of the body.



### WARNING

- The sudden closing of a locker due to a gust of wind or movement of the boat could result in injury.



### PIECE OF ADVICE - RECOMMENDATION

- Close the deck hatches and fore portholes each time before each trip (including the companionway hatch in heavy weather).

Closure Companionway



Door holding - Closed position



Door holding - Open position



Cockpit locker \_ Central



Closure Hatch cover



Cockpit access door - To be kept closed when sailing



# Deck 4

Cockpit table  
Mechanism Opening / Closure



Socket 12V - Lighting



Lamp switch





## ■ TOWING

### TOWING BOAT

- Tow another boat at a reduced speed and as smoothly as you can.
- Pay particular attention when you throw or catch the towing rope (it may foul on the propeller).

**NOTE:** *The stability may be reduced when you tow a boat.*

### TOWED BOAT

Keep steering your boat and see to it that you stay in the wake of the towing boat.

Inappropriate towing can damage your vessel, do not tow at more than 6 knots.

## ■ ANCHORING

As a rule, set the anchor in at least 3 times the depth of water.

### ANCHORING WITHOUT WINDLASS

- Have your boat pointed into the wind and without speed.
- Pay out the chain while moving back slowly.
- Once the anchor has taken hold make it fast by reversing slowly.
- Secure the hawser or the chain to the cleat.

### ANCHORING WITH ELECTRIC WINDLASS

- Turn on the boat engine.
- Check that the electrical supply of the windlass is switched on (battery switch, circuit breaker).
- Use the remote control to activate the windlass in lowering mode. Let the chain feed out by keeping the lowering button on the remote control pressed down.
- Let the chain out while moving backwards slowly and as straight as possible.
- Once the anchor has taken hold make it fast by reversing slowly.
- Secure the hawser or the chain to the cleat.



### WARNING

Windlass operations are dangerous:

- Always keep the anchor line free and unfouled.
- Always proceed with care, using gloves and always wearing shoes.
- If your boat is equipped with the twin control optional extra, make sure you use **only one** control at the same time.



### PRECAUTION

- Before anchoring check the depth of water, the power of the current and the nature of the sea bed.
- Anchoring manoeuvres with the electric windlass can only be carried out with the engine running.



# Deck 4

## ELECTRIC WINDLASS - BREAKER - FUSE



1. Bow fitting
2. 12V 1000 W Electric windlass
3. Mooring locker
4. Handle position (The handle is used to disengage the chain rim brake and to haul in the anchor manually in the case of electrical breakdown)

5. Handle
6. Remote control
7. Clench
8. Smooth gypsy head
9. Chain rim 10 mm diameter

### Operation relay - Acces: Forward cabin

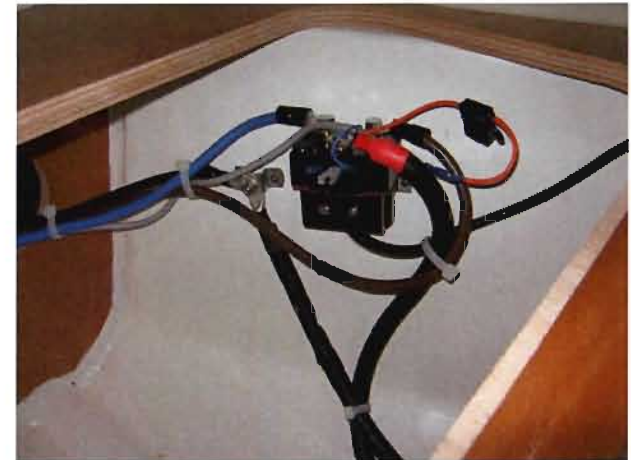

### Lay out of Battery switch



1. Battery switch "common negative"
2. Battery breaker - "positive terminal - engine"
3. Battery switch "service positive"

### Breaker - 100 A



## ANCHORING BY HAND WITH USE OF A MANUAL WINDLASS

- Release the windlass brake using the handle located in the chain locker so as to allow the chain lifter to turn freely and to release the anchor from the stem fitting
- Re-engage the brake and let the anchor hang until the mooring position is reached.
- Have the boat pointed into the wind and without speed.
- Release the brake and pay out the chain slowly.
- Control the speed of anchor lowering using the brake.
- Once the anchor has taken hold re-engage the brake and secure the hawser to the cleat.

## HEAVING UP THE ANCHOR

- Lock the cable lifter snubber.
- Ensure the chain is properly set on the cable lifter.
- Slowly go near the anchor, using your engine (Don't use your windlass to winch the boat).
- Heave the anchor completely.
- Visually check the last meters till the anchor gets into contact with the davit.
- If you just change berth, check the position of the anchor on the stem fitting.
- For sailing, store the anchor in the chain locker or fasten the anchor to its roller.
- For electrical windlasses cut off the power supply as soon as the anchor has been lifted.

## STERN ANCHORING

Stern anchoring shall be performed with the engine declutched.

- Secure the required length of cablet on the mooring cleat.
- Pay out the anchor line slowly.
- Take care not to damage the propeller or the rudder.



### PIECE OF ADVICE - RECOMMENDATION

- After each trip rinse the windlass and mooring line with fresh water.
- Refer to the manufacturer's instructions for windlass maintenance at the beginning or end of the season.
- Check the swinging area once the boat is at anchor.



### PIECE OF ADVICE - RECOMMENDATION

- For sailing with anchor in position:
- Free the chain tension using the windlass before closing the mooring locker hatch.



## ■ MAINTENANCE OF THE DECK

Preferably wash your boat on shore.

Use as few cleaning agents as possible.

Don't use solvents or aggressive detergent agents (Refer to chapter 3 "Hull").

Don't discharge cleaning products into the sea.

Regularly brush the deck with a degreasing shampoo and fresh water.

### DECK FITTING

- Rinse thoroughly all your equipments with fresh water.
- Periodically lubricate turnbuckles, winches, tracks and travellers with water-repellent grease. Thoroughly and frequently wash off the pulleys and sheaves with clear water.

### SOLID WOOD ON EXTERIOR WOODEN PANELLING

Regularly clean the woodworks with fresh water using a sponge (if need be add some gentle soap).

### PLEXIGLAS

- Rinse plexiglas with fresh water.
- Use a polish paste for thin scratches.
- Consult your dealer concerning deep scratches.

### EXTERIOR CUSHIONS

Bring the removable cushions inside (washed with soapy water then dried) when the vessel is inoccupied.

### STAINLESS STEEL

Stainless steel is not incorruptible and requires a minimum of upkeep:

- The use of chrome tools is preferable whenever handling stainless steel.
- Re-nourish the protective film regularly with passivation paste (consult your dealer).



### PRECAUTION

- Consult the harbourmaster's office to find out the conditions of use for water and air facilities for cleaning your vessel.
- Don't use solvent, alcohol, acetone on plexiglas.



### PIECE OF ADVICE - RECOMMENDATION

- Use only products similar to the ones that are included in the maintenance case you have been delivered with your boat.
- Don't use a pressure washer.





# Steering system

5

- Steering Gear

## SCHEMATIC DIAGRAM

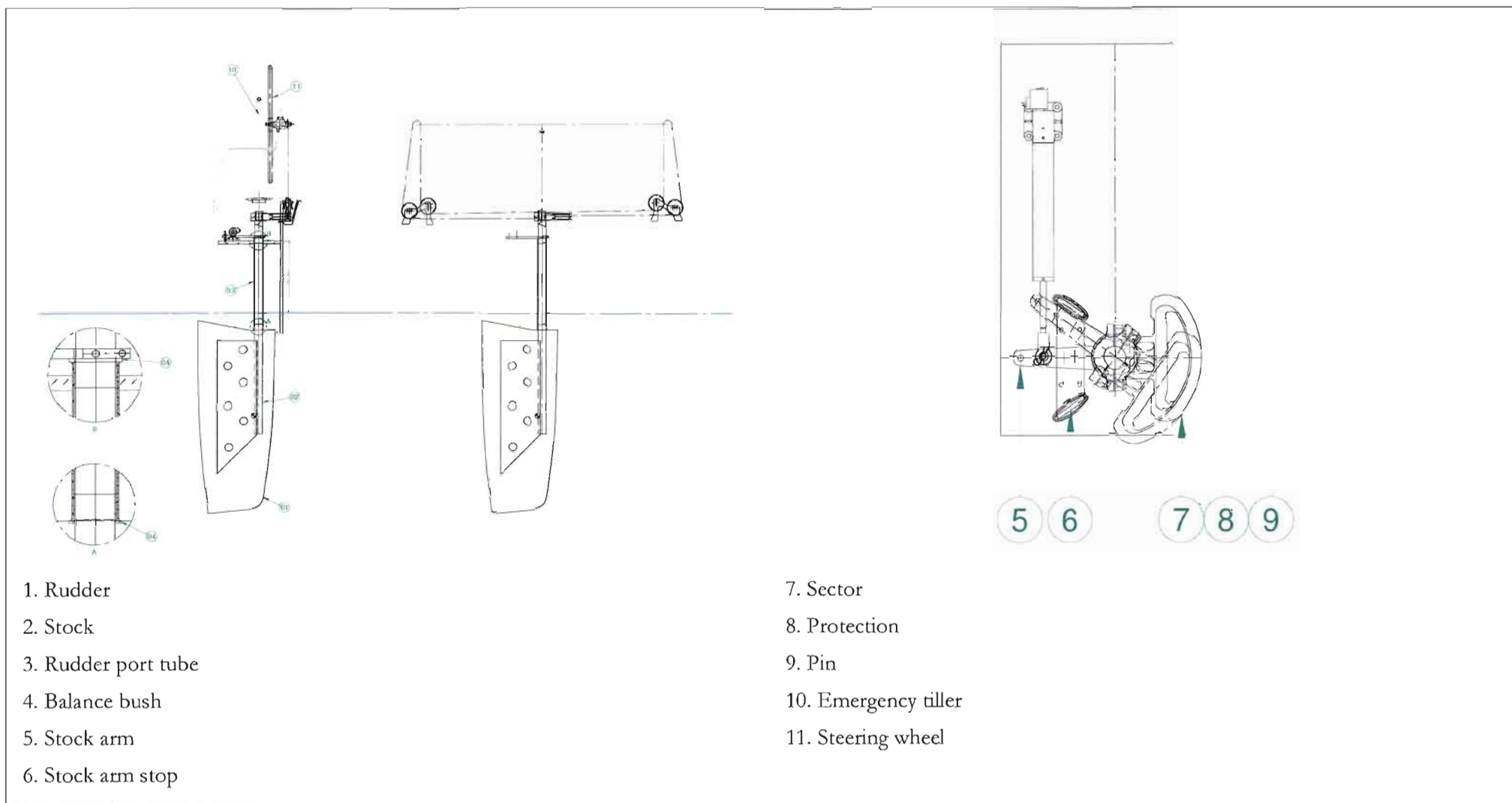

- 1. Rudder
- 2. Stock
- 3. Rudder port tube
- 4. Balance bush
- 5. Stock arm
- 6. Stock arm stop

- 7. Sector
- 8. Protection
- 9. Pin
- 10. Emergency tiller
- 11. Steering wheel

# Steering system 5

## ■ STEERING GEAR

### CABLE ADJUSTMENT - STEERING SYSTEM

The steering gear is assembled and pre-adjusted at the factory, however, only actual use at sea will enable the steering cable to find its definitive position around the wheel drum.

For this reason, it is necessary to re-adjust the gear after the first few sea outings.

The adjustment is made on the nut and bolt system integral with the steering cable at the join with the profile. To check the adjustment exert a perpendicular force on the cable between the wheel drum and the return sheaves located on the hull.

### MAINTENANCE

- Regularly check:
  - The tension in the steering cables.
  - The tightness of the steering system components.
- Don't tighten the steering cables excessively.
- Lubricate all the elements.

Maintain the nylon, ertalon or teflon bushes only with a suitable lubricant.

*NOTE: Do not hesitate to consult your dealer about system maintenance.*

**Access to steering gear:  
Port aft cabin**



### WARNING

- The steering system is a feature of sailing safety and for this reason must be verified at least once a year.
- THE STEERING CABLE MUST BE CHANGED EVERY 10 YEARS.**



### WARNING

- Learn how to judge the necessary distance of deceleration for the vessel to come to a complete stop.
- Refer to chapter 2 "Safety" for use of the emergency tiller.



### PIECE OF ADVICE - RECOMMENDATION

- The emergency tiller is designed only to sail at a reduced speed in case of a wheel failure.



## Rigging and Sails

- Standing rigging
- Running rigging
- Winches
- Sail setting
- Sails

ALL VERSIONS

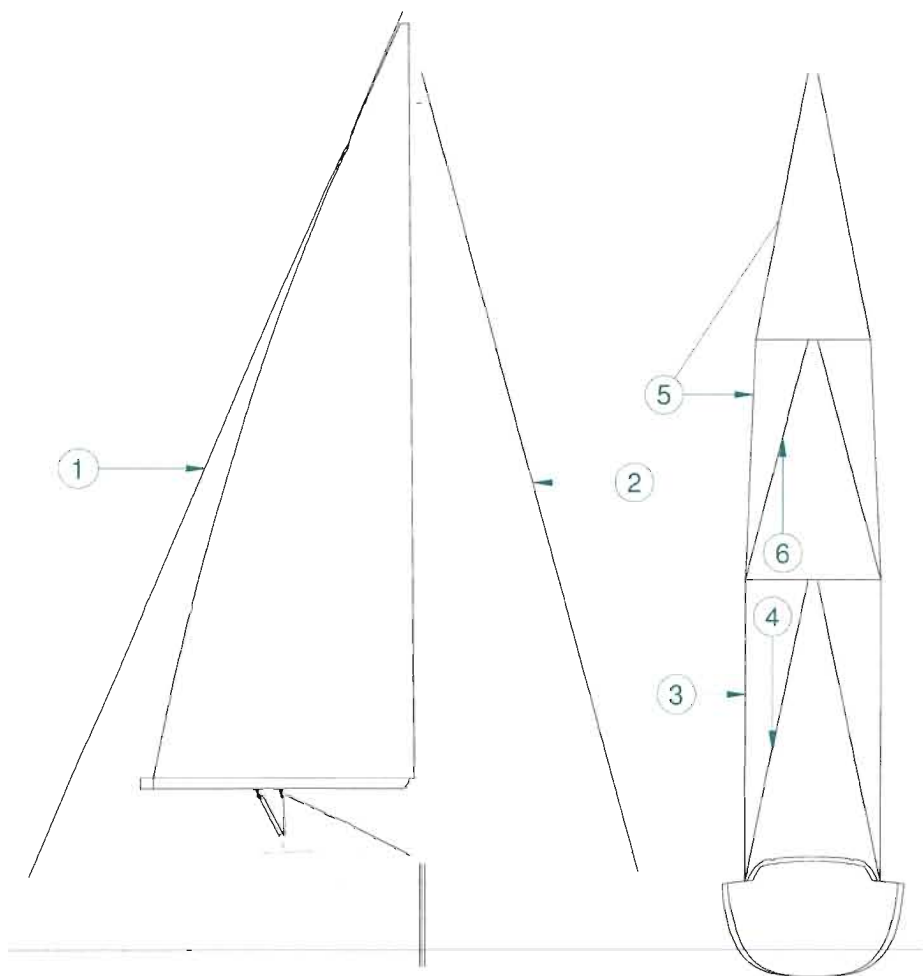

REF	Rigging	Quantity	Diameter (mm)
1	Forestay	1	10
2	Backstay	2	7
3	V1	2	10
4	D1	2	10
5	V2D3	2	8
6	D2	2	7

## ■ STANDING RIGGING

Your BENETEAU dealer was responsible for stepping the mast of your boat.

After masting your vessel and after having sailed for the first time it is necessary to seek the help of a qualified specialist in order to carry out a rigging check.

### MAINTENANCE

Before each trip, carefully inspect the mast from top to bottom.

Periodically check the rigging tightening and the lock nut or pin locking (you should check it for the first time after a few days sailing in all types of weather).



### DANGER

- To hoist a crew member up to the top of the mast, make a bowline with the halyard directly on the bosun's chair ring
- (never use the halyard snap shackle or shackle).
- Do not hoist a crew member when sailing in heavy weather.



### PIECE OF ADVICE - RECOMMENDATION

- Your dealer BENETEAU can carry out all maintenance operations or recommend a skilled specialist to do so.



**GENERAL HANDLING DIAGRAM**

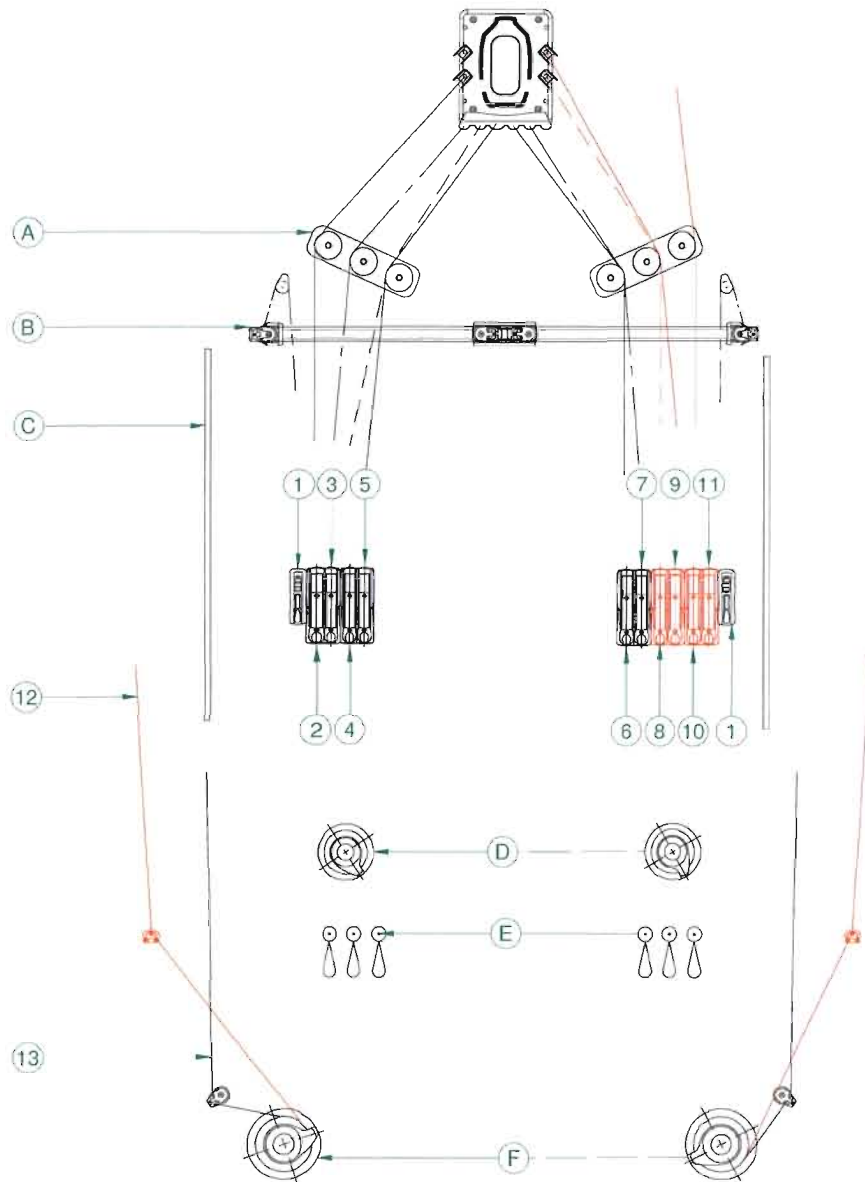

Version - Classical	
REF	Designation
1	Traveller adjustment - Mainsail (classic)
2	Main halyard
3	Kicking strap
4	Mainsail foot
5	Main sheet
6	Reef 1
7	Reef 2
8	Spinnaker halyard
9	Fore stay sail halyard / Boom lift
10	Spinnaker boom downhaul
11	Forestay sail furler line

Version - Jib reefers	
REF	Designation
1	Traveller adjustment - Mainsail (classic)
2	Genoa halyard
3	Main halyard
4	Mainsail foot
5	Main sheet
6	Kicking strap
7	Mainsail safety block stopper
8	Spinnaker halyard
9	Boom lift / Fore stay sail halyard
10	Spinnaker boom downhaul
11	Forestay sail furler line

All versions	
REF	Designation
12	Spinnaker sheet
13	Genoa sheet
A	Cheek block
B	Mainsail track
C	Genoa track
D	Rigging winches
E	Bollards
F	Genoa sheet winches

## ■ RUNNING RIGGING

### MAINTENANCE

Lightly grease the sheave pins. Change any distorted or dented sheave. Inspect the pins of the sheaves at the top of the mast once a year.

Regularly check the jam cleat jaws for condition.

Inspect the halyards for wear and condition.

Regularly clean the pulleys off (old grease, traces of rust) with clear water.

Slightly lubricate the block pins.

Avoid untimely gybing in order to reduce premature wear on the sheets, attachment points and the gooseneck.

## ■ WINCHES

### OPERATION

Avoid rope jamming during winch handling. Do not leave loose ropes on the winches but fasten them on cleats (except on the "Self Tailing" winches).

## ■ SAIL SETTING

### CLASSICAL MAINSAIL

With the mainsail being on the deck:

- Screw the pins of the mast sliders for battens into their boxes.
- Slide in the battens through the leech.
- Screw the box cap until you get the required tension (the tightening screw shall not project beyond the sail).
- Do not forget the small locking screw.
- Put the mainsail into the lazy-bag.
- Set the boom ring in velcro about level with the clew.
- Fit the mainsail onto its slides, begin with the headboard and finish with the tack.



### WARNING

- Refer to the manufacturer's instructions to remove the winches and put them back.
- Improper refitting may result in accidents (e.g. kick of the crank handle).

### SYSTEM - MAINSAIL (CLASSIC)

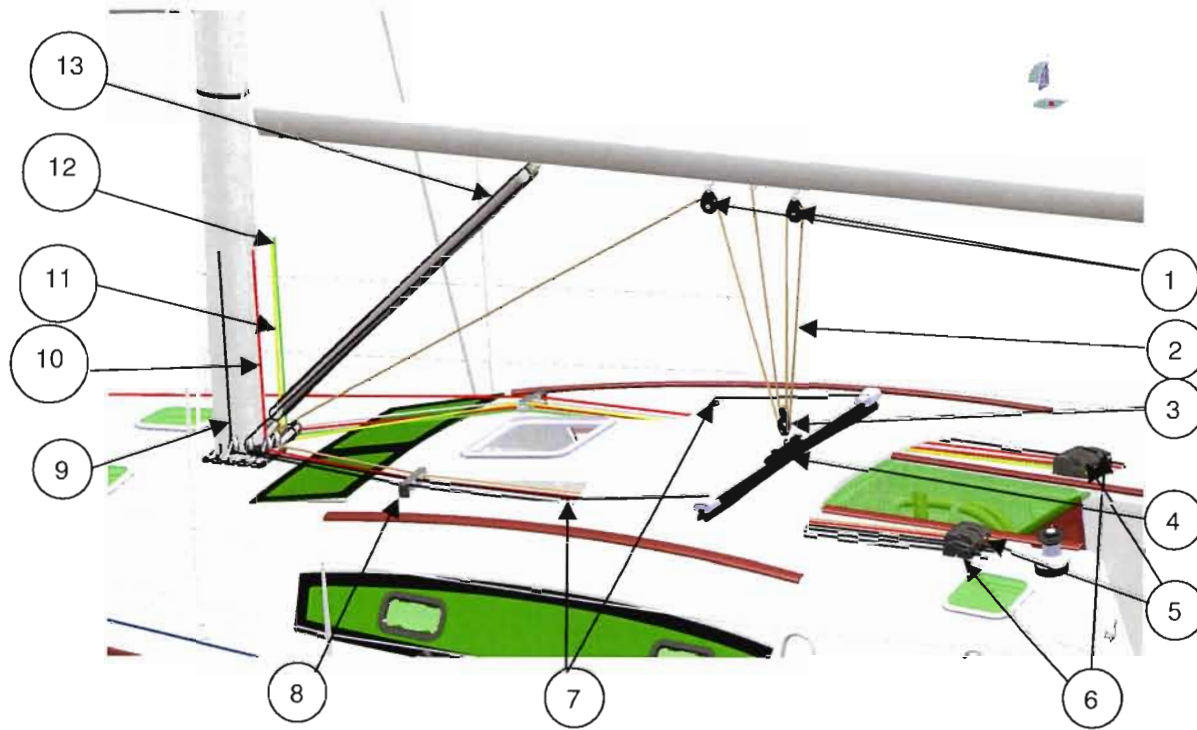

REF	Designation	REF	Designation
1	Traveller adjustment - Mainsail (classic)	8	Cheek block
2	Main sheet	9	Main halyard
3	Fiddle block	10	Mainsail foot
4	Mainsail track	11	Reef line 1
5	DOUBLE CLUTCH	12	Reef line 2
6	Single clutch	13	Fixed boom kicking strap
7	Single cheek block		

## FURLING GENOA: FITTING

- Secure the head and halyard to the swivel. Secure the tack to the drum and sheets.
- Insert the bolt rope into the hole and hoist it and take care that you do not tear it.
- Have the halyard taut enough but hoist less taut than a sail on a normal stay. Hoist it until the horizontal creases disappear (Adjust the tension of the luff after a few sea trips).
- Pull on the line from the cockpit to furl the genoa.
- Before getting under way take advantage of a windless period of time and hoist the genoa.
- Hand pre-roll the drum to set the furling line on it.

Pay attention to the drum winding direction: The sacrificial strip of the genoa shall be wrapped outside.

Never force it in case it seizes when you furl or unfurl the head sails. Make sure that no ropes are caught in the furler.

## MAINTENANCE

- Regularly rinse the drum and swivel.
- Lubricate the bearings if recommended by the manufacturer.
- Unrig the sails if your boat is not to be used for long.

## LAZY-BAG: FITTING

- Spread out the lazy-bag on the deck.
- Slide the battens in and close the batten pockets.
- Hank on the lazy-bag until you have the front part about level with the gooseneck.
- Fasten the lazy-bag to the tack with the strap provided.
- Stretch the lazy-bag from the back before you fasten the lazy-jacks.
- Put the mainsail into the lazy-bag.



### PIECE OF ADVICE - RECOMMENDATION

- When you are not sailing, slacken the genoa halyard.
- Install the lazy-bag before the mainsail.
- When the sail is unfurled, adjust the halyard tightness.
- Too much tightness may cause furling problems.
- After taking in a reef for the first time mark the halyard position at the clutch (marker pen or light stitched label) in order to be able to let out the sheet with precision in subsequent manoeuvres.



### PIECE OF ADVICE - RECOMMENDATION

- Carry out the complete maintenance of the winches regularly (before and during the sailing season).
- Rinse the winches off regularly during the season.

### SYSTEM - GENOA

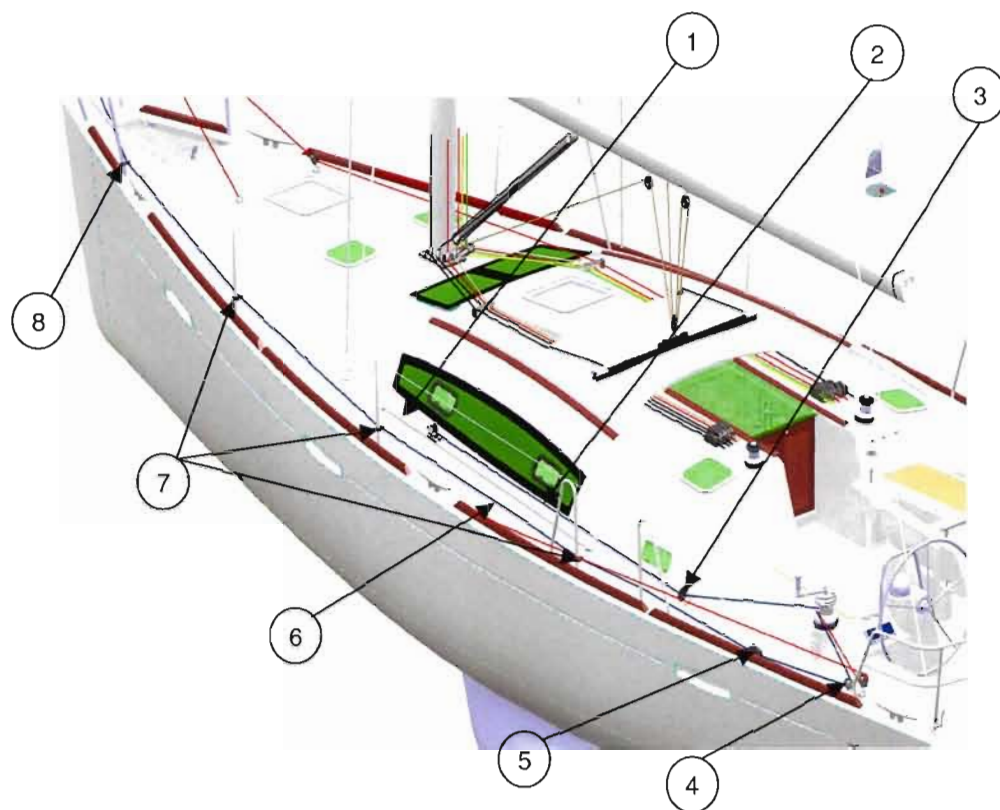

REF	Designation	REF	Designation
1	Genoa track	5	Single clutch
2	Genoa sheet	6	Furling line
3	Single cheek block	7	Stanchion fairleads
4	Single pulley - 60 mm diameter	8	Stanchion block

# Rigging and Sails 6

## SYSTEM - ASYMMETRIC SPINNAKER

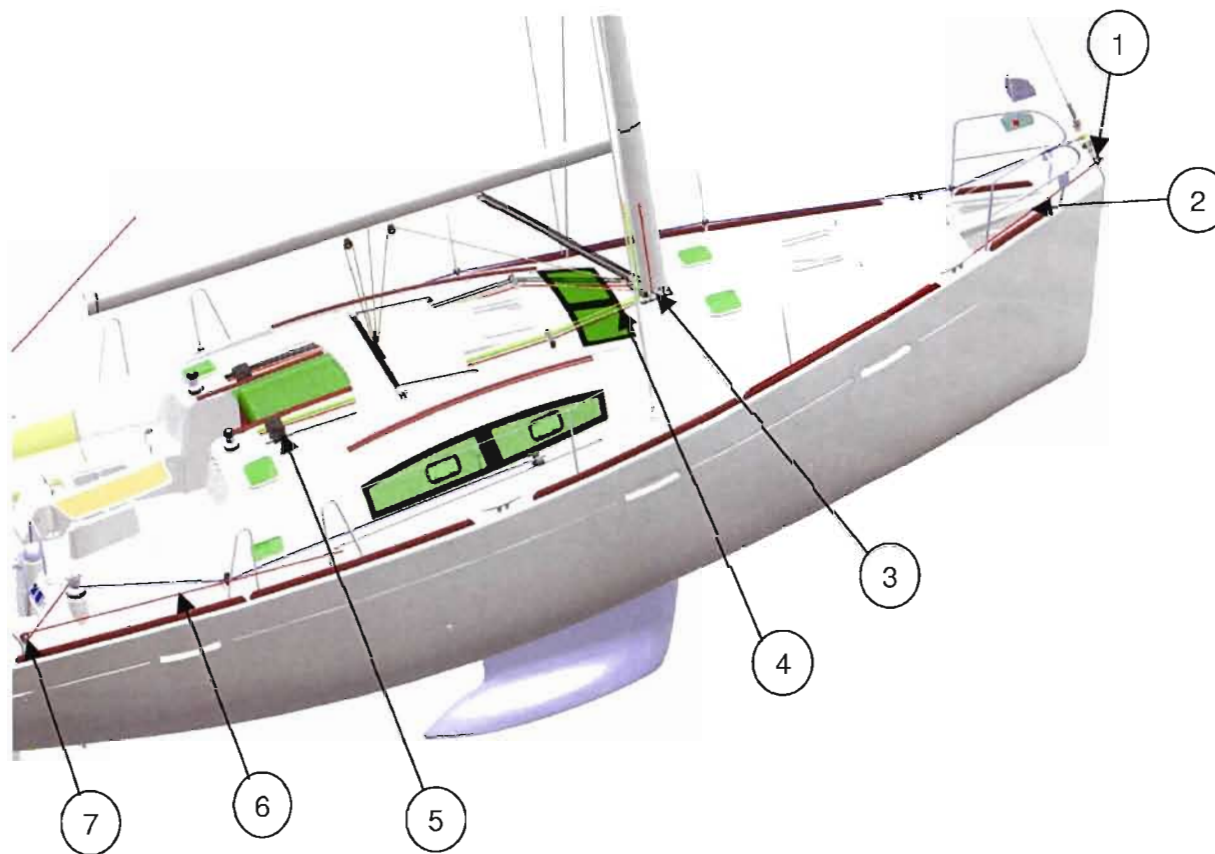

REF	Designation	REF	Designation
1	Single pulley - 72 mm diameter	5	Single clutch
2	Pig tail	6	Spinnaker sheet
3	Single pulley	7	Single pulley - 90 mm diameter
4	Spinnaker halyard		



### System - Symmetric spi

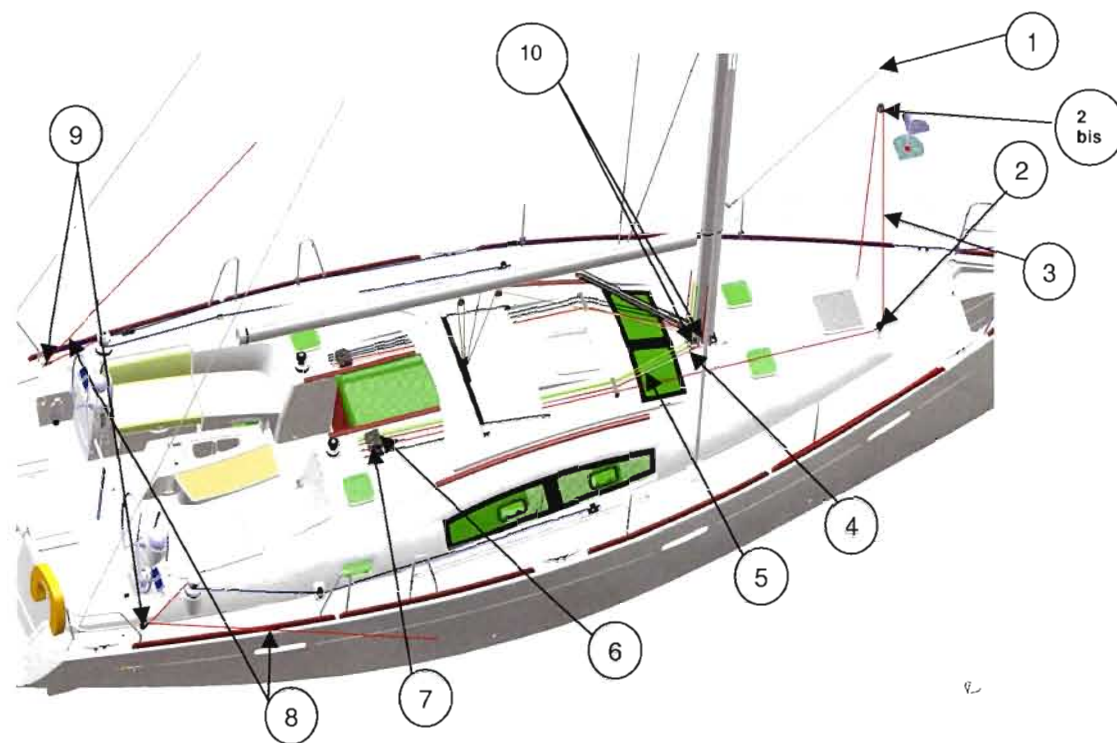

REF	Designation	REF	Designation
1	Boom	6	DOUBLE CLUTCH
2	Single pulley - 72 mm diameter	7	Single clutch
2 bis	Single pulley - 72 mm diameter + SHACKLE Lyre	8	Spinnaker sheet
3	Spinnaker boom downhaul	9	Single pulley
4	Spinnaker halyard	10	Single pulley - 90 mm diameter
5	Boom lift		

## ■ SAILS

How long a sail lasts mainly depends on its regular maintenance.

When sailing, trim the sails properly in accordance with the stresses in order to reduce the harmful strains on the fabric.

Avoid tears and wear: Use protective items against chafing on the the accessories with rough surfaces (protective items for spreaders, stanchions etc.).

Have a sail maker's kit and a user's manual so that you may carry out the emergency repairs waiting for the sailmaker's assistance.

### SHORTENING THE STANDARD MAINSAIL

To shorten sail:

- Head into the wind.
- Slacken off the kick strap.
- Slightly slacken the mainsail sheet.
- Slightly slacken the mainsail halyard.
- Take in the reef line.
- Take up the slack in the mainsail halyard.
- Reset the mainsail sheet.
- Take up the kick strap slack if necessary.



### PIECE OF ADVICE - RECOMMENDATION

- At the end of the sailing season, and if possible before winter, leave your sails to a specialist to have efficient maintenance and repairs.



## **CLEANING AND MAINTENANCE**

Rinse the sails with fresh water from time to time and dry quickly in order to avoid mildew.

Avoid drying the sails to windward when on the mast (when the sails lift, the seams are worn, the sails may be torn by the rigging).

## **HAULING DOWN THE STANDARD MAINSAIL**

To haul down the mainsail:

- Head into the eye of the wind.
- Slacken off the kick strap.
- Take up the slack in the Lazy bag and uphaul ropes.
- Slacken off the mainsail halyard while taking up the reef lines to control the mainsail descent.
- Fold the mainsail into its lazy-bag.
- Take up the mainsail sheet to immobilise the boom.
- Immobilise the mainsail halyard.

## **SAIL STORAGE/FOLDING**

Avoid storing a wet sail to prevent mildew from appearing.

Accordion fold the sail parallel to the foot, then roll it up to the bag dimensions.

## **PROTECTION**

UV rays are harmful to polyester and nylon. If the sails remain on the mast, even for 24 h, protect them with a cover or a protection fabric placed on the leech and foot of the furled sails.

Our distributor network offers you accessories that have been selected by the yard and are consistent with your needs.



## Interior

- Introduction
- Interior maintenance
- Maintenance of fabrics

Version 2 cabin



Version 3 cabin



Version 4 cabin

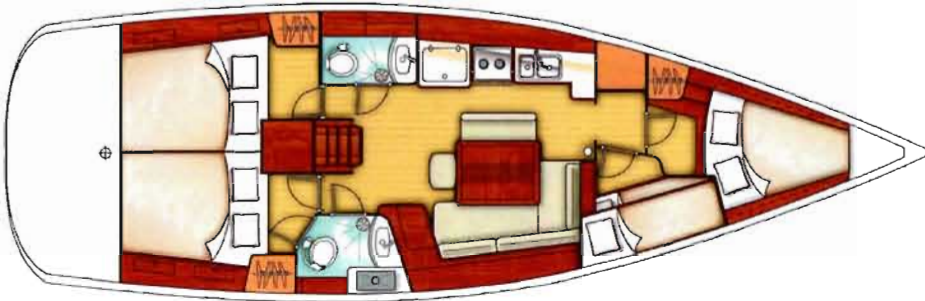

Charter version





## ■ INTERIOR MAINTENANCE

### INSIDE

- Take advantage of the fine weather to take the settee and berth cushions out.
- Put the cushions vertically if you leave the boat for long.
- Use blinds to protect the inside of the boat against UV rays.
- Carefully remove all crumbs.
- Make sure the bilges are clean and dry.
- Installed in the square of a dehumidifier air leaving the cabin doors and open storage (cupboards, coolers).
- Defrost the fridge regularly/Cool boxes.
- During long absence leave the fridge and icebox doors open to avoid mould developing.

### INSIDE VARNISH

- Rinse the inside varnish with fresh water mixed with spot remover and shampoo.
- Polish the inside varnish with shammy leather.

## ■ MAINTENANCE OF FABRICS

### STAIN REMOVAL

- Dab with a clean rag.
- Remove the stain with a solvent poured onto a clean rag. Never pour the solvent directly over the stain.
- Rub with a clean and dry rag.
- Brush the fabric against the grain.
- Use the vacuum cleaner when the fabric is dry.

### PVC OR COATED FABRICS

- Use a sponge and water and soap (household soap type).
- Dab away resistant stains with a rag soaked with white spirit, do not rub them.



### PRECAUTION

- For the PVC fabrics, don't use any solvent or solvent based product (pure alcohol, acetone, trichloroethylene).



### PIECE OF ADVICE - RECOMMENDATION

- Preferably wash your boat on shore.
- Use as few cleaning agents as possible.
- Don't discharge your cleaning product into the water.
- Take the removable upholstery inside when the vessel is not being used.
- Place protective covers/awnings.
- Mark up each cover and foam when dismantling.

**Blackout curtain / mosquito nets**



**Ventilator**



**Suction-cup system to lift floors**



## **100% POLYESTER/DRALON JACQUARD**

If you cannot remove the fabric:

- Clean with the vacuum cleaner.
- Clean with synthetic foam (please refer to the product instructions).

If you can remove the fabric:

- Hand wash with an ordinary washing powder at 30° C.

In both cases, dry cleaning is possible. Remove the stains as soon as possible with a damp rag.

## **COTTON JACQUARD**

- Dry clean.
- Do not iron.
- Do not use hypochlorite.
- Remove the stains with fractionated petrol.

## **ALCANTARA**

- Wash in warm water with a neutral pH soap.
- Dry it naturally.
- Dry clean with perchloroethylene.

## **LEATHER**

- Use a leather cream for ordinary care.
- Do not use detergent.
- Do not use silicone based products.
- Clean with a sponge and soapy water.
- Remove ball point pen marks with methylated spirit.
- Remove the grease stains with an absorbent powder (e.g. talcum powder).



## Water and sewage water

- Water tanks
- Water system - Distribution
- Water system - Drainage
- Sewage

**Forward water tank**  
Lay out of: Forward cabin  
Capacity: 160 liter



**Aft water tank**  
Lay out of: Starboard aft cabin  
Capacity: 200 liter



**Deck fillers**



**Gauge**

Lay out of: Electrical panel  
Tank 1 = Forward tank  
Tank 2 = Aft tank  
Refer to the instructions for use



## ■ WATER TANKS

### OPERATION

In order to prevent any handling mistakes, never fill the water and fuel tanks at the same time.

During filling, avoid handling contaminants near the fillers.

Open and close the filler caps with the suitable key.

Check the filler cap seals for condition during filling.

The tanks are fitted with overflow outlets and vents.

Never insert the water filling hose deep down into the system in order to prevent any over-pressure in the systems.



### WARNING

-Tanks nominal load capacity cannot be fully used based due to trim and boat loading. A 20% reserve should be kept.



### PIECE OF ADVICE - RECOMMENDATION

-Pay attention to the quality of the water for the filling up. Check if it is drinking water.

-It is possible to sterilize the tanks with a Clonazione tablet (sold at the Chemist's).

-If the boat is not used for long, purify the tanks and pipes with acetic acid (or white vinegar).

-For winter storage instructions and precautions, refer to Chapter 12.



**PLUMBING BOARD  
LAY OUT OF: STARBOARD SALOON**

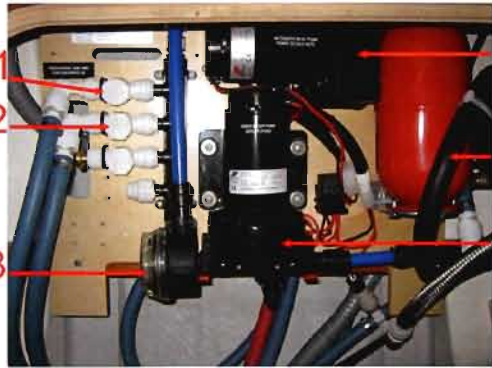

1. Supply - Forward tank
2. Supply - Aft tank
3. Filter
4. Electric bilge pump 12V
5. Accumulator tank
6. Water pump 12V

**Water heater**



1. Thermostatic mixer valve
2. 220 V socket
3. 25l water heater

**Control on the electrical panel**



## ■ WATER SYSTEM - DISTRIBUTION

### USE OF THE WASHBASINS AND SHOWERS

- Close the valves and turn off the taps after use.

### SEA WATER FOOT PUMP

The footpump makes either seawater available at the sink.

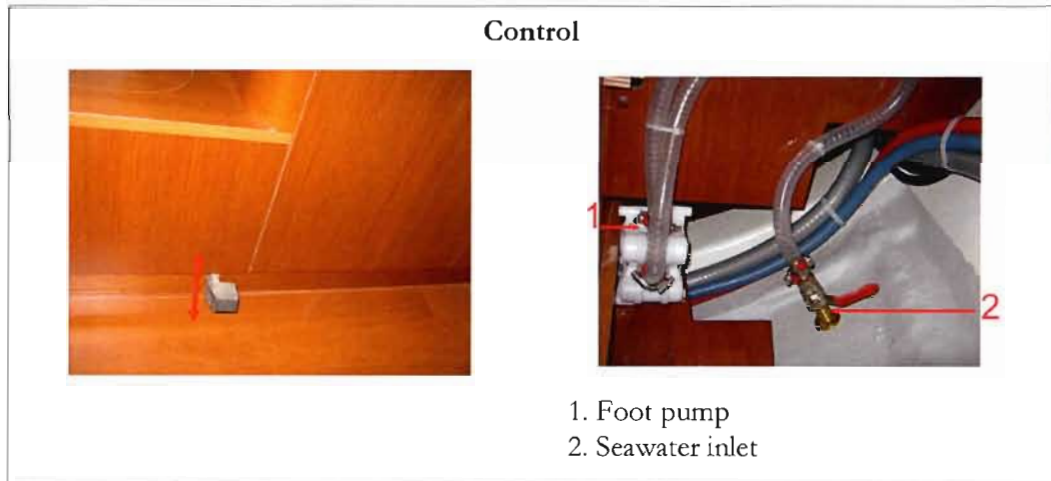

### WARNING

- Turn off the shore freshwater supply valve before leaving the vessel.



### WARNING

- Bleed the cockpit shower circuits and the deck washing pump to prevent freezing.



### PRECAUTION

- Never operate the water system equipment when the valve is closed or the tank is empty (the electrical equipment may be damaged).
- Check the water filter for condition (refer to manufacturer's instructions).
- Close the taps of empty tanks.

COCKPIT SHOWER SPRAY

Lay out of



- 1. Mixer tap
- 2. Shower

## ■ WATER SYSTEM - DRAINAGE

### OPERATION

Waste water from the sink, washbasins and heads is drained off by thru-hull fittings with ball valves (the valve is closed when the valve handle is perpendicular to the hose, the valve is open when the valve handle is in line with the hose).

All the floors have holes (limber holes) for the water flow.

A watertight bilge tray under the engine receives the possible oil leaks.

A main sump located above the ballast receives water from the bilges.

The main sump is partially drained by an electric or a manual pump. Regularly dry the sump with a sponge.



### PIECE OF ADVICE - RECOMMENDATION

- Regularly check the valves and thru-hull fittings for proper operation and watertightness.
- Turn off the valves when the water system is not in use.
- Visually check the water pump flow.
- Check the clamps and flexible hose connections for tightness.
- Pay attention to the seals for condition.
- Regularly make sure that the strum box and bilge are perfectly clean.
- Immediately switch off the electric system in case a pump is running while all the water supplies are turned off.
- In case of a leak check the system.

\*



Thru-hull fitting closed

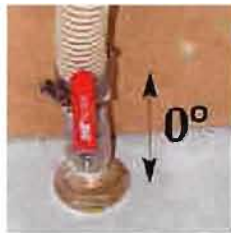

Thru-hull fitting open

### DRAIN PLUG



### COOL BOXES - SINK

- 1. Pump - Icebox drainage
- 2. Sink draining + Cool box

Control - Icebox drainage



### Shower draining

- 1. Draining pump for shower
- 2. Shower draining + Washbasin

Control

Draining pump for shower



### ■ SEWAGE

#### USE OF THE MARINE HEADS

Before you use the heads, check that the water intake valve and draining valve are open.

To empty the bowl:

- Set the control lever of the pump slantwise (FLUSH).
- Operate the pump.

To dry the bowl:

- Set the lever back vertical (DRY).
- Operate the pump.

To avoid blocking the toilets only use absorbent paper in reasonable quantities.

Schedule a regular rinsing through of the heads with fresh water.

Close the valves after each use (in particular when the boat is unattended).



#### PIECE OF ADVICE - RECOMMENDATION

- When you are in a marina, use the club-house sanitary facilities (if there are).
- Since it is prohibited to discharge sewage water in certain marinas or countries it may be necessary to use the foul water holding tank ("WHT").



## ELECTRIC TOILET

The electric toilets operate with seawater only. A switch enables the water intake and drain cycle of the bowl to be activated. A switch enables the bowl to be rinsed.

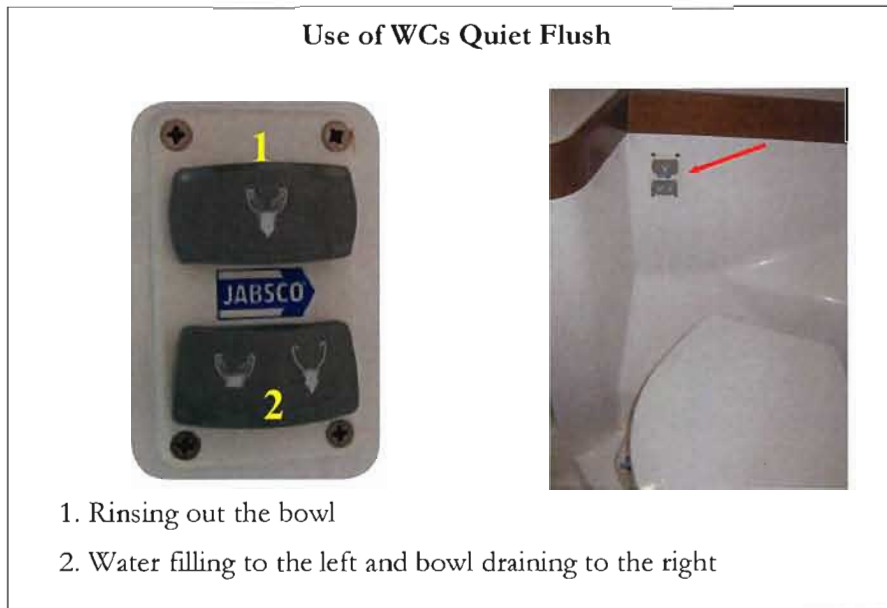

### PIECE OF ADVICE - RECOMMENDATION

- Completely empty the black water system before stationing the vessel in negative temperatures.

## RESPECT OF THE ENVIRONMENT

- Remain informed of local regulations concerning the environment and follow the codes of best practice.
- Do not drain the contents of the sewage tank near the coast or in zones where it is forbidden.
- Make use of the port or marina pump facilities to drain the sewage tank before leaving port.
- Find out the international regulations against marine pollution (Marpol) and follow them as far as possible.



# Water and sewage water 8

## Black water circuit - Schematic diagram

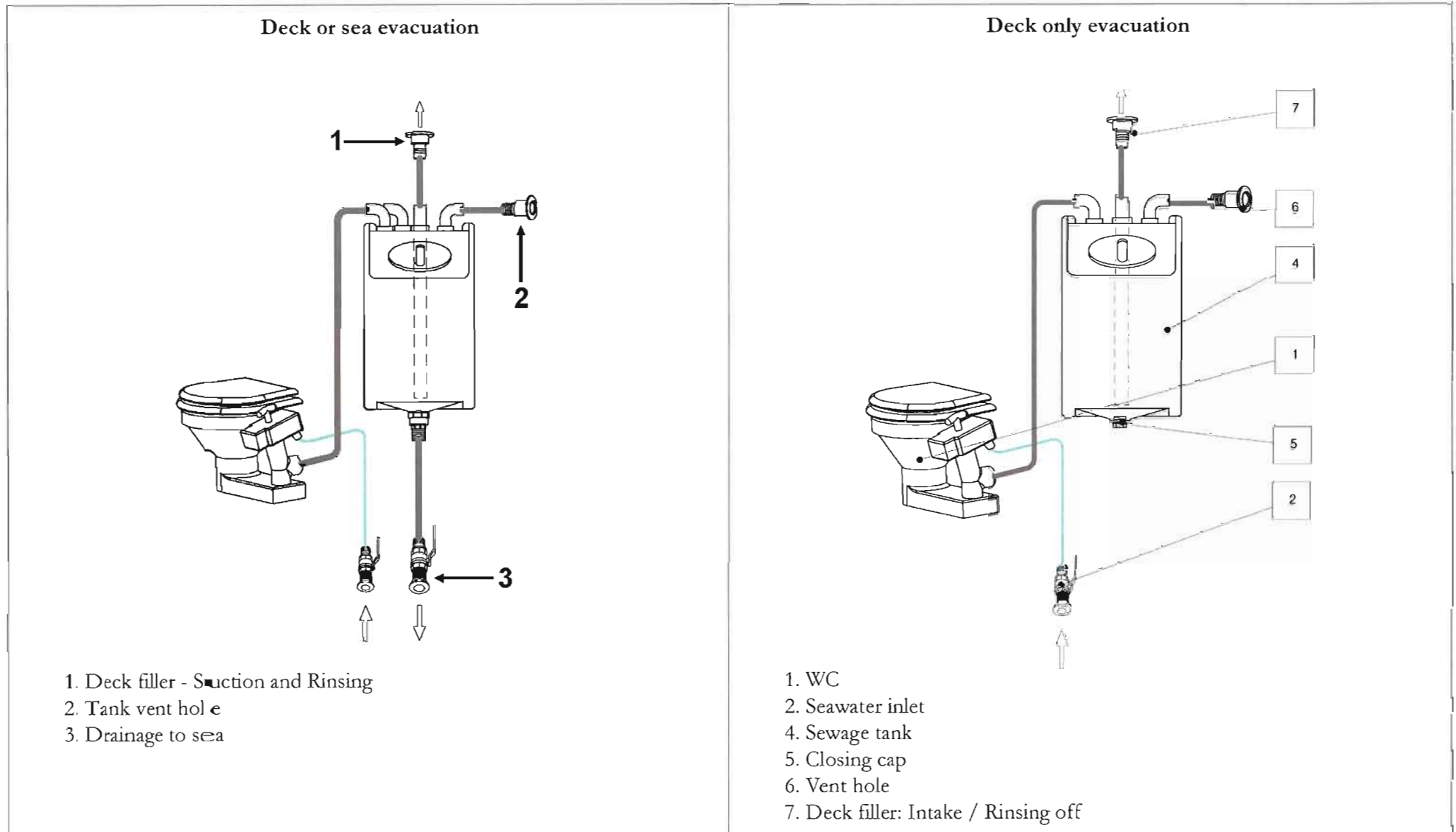

**Sewage tank**

Capacity: 73 liter



**WC - To port**

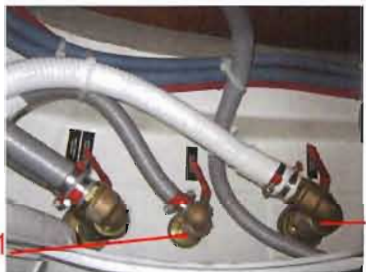

- 1. Seawater inlet WC
- 2. Drainage to sea

**WC - To starboard**



- 1. Drainage to sea
- 2. Seawater inlet WC

**WC evacuation - Deck**



## Water and sewage water 8

### USE OF MARINE WCs FITTED WITH BLACK WATER TANK

Open the water intake valve (valve handle parallel to the pipe).

In the case of a direct discharge into the sea: Open the draining valve.

In case you store the waste waters in the tank: Make sure the draining valve is closed (valve handle perpendicular to the pipe).

To drain the bowl, set the control lever of the pump slantwise (FLUSH) then operate the pump.

To dry the bowl, set the lever vertical (DRY) then operate the pump.

In order to avoid clogging the heads:

- Only use absorbent paper in reasonable quantities.
- Schedule a regular rinsing through of the system with fresh water.
- Always retain a little water in the bottom of the bowl to avoid smells

To empty the tank:

- In an authorized area, open the draining valve.
- In a marina equipped with a system to suck the waste waters, put the sucking hose into the tank through the deck filler. Start the pump of the sucking system. The filler caps are opened and closed with an appropriate key. When the tank is empty, check the cap seal for condition then close the filler.



#### WARNING

- Tanks nominal load capacity cannot be fully used based due to trim and boat loading. A 20% reserve should be kept.



#### WARNING

- Ask for information about the laws in force in your country or your marina about discharging your waste waters into the sea.



#### PRECAUTION

- Close the valves after each use and above all when the boat is unattended.



#### PRECAUTION

- Regular check the tank level. High pressure due to too high a level may cause leaks or more unpleasant troubles.



## Electrical equipment

- General information
- 12 V DC system
- 110-220 V AC system
- Equipment

## 12 V ELECTRICAL PANEL

Lay out of: Chart table

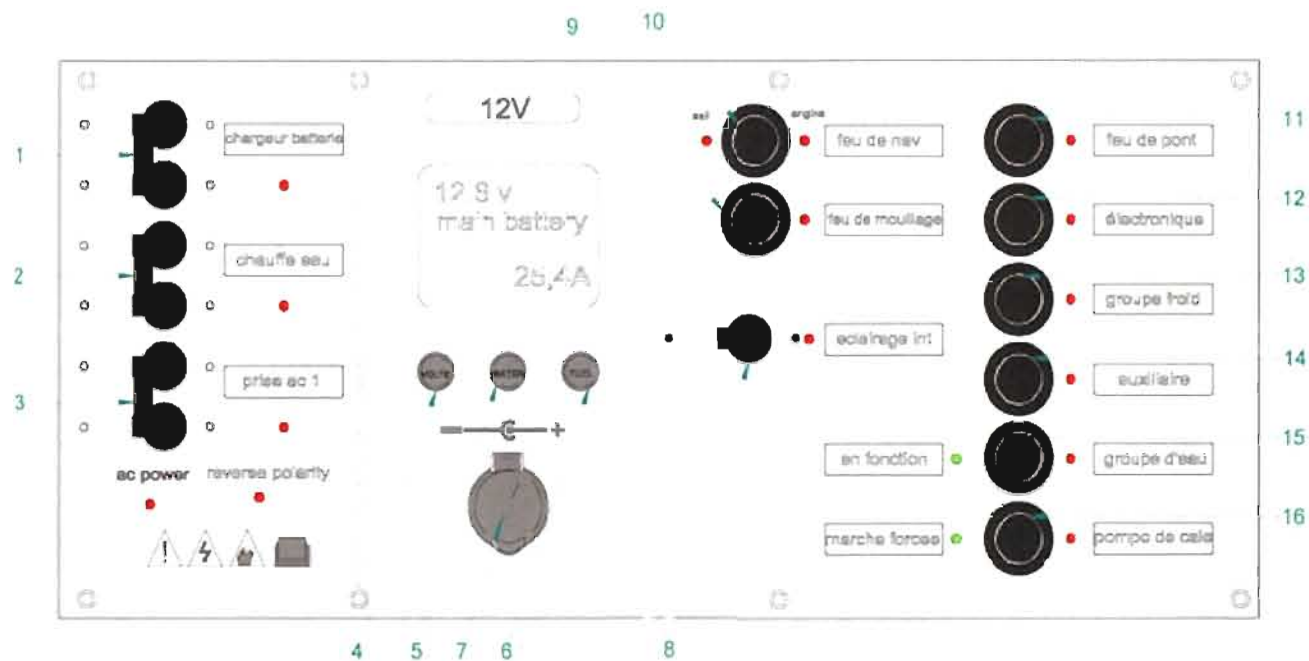

REF	Designation	Fuse
1	Battery charger	10A
2	Water heater	10A (220V) or 15A (110V)
3	Sockets 110V or 220V	10A
4	Voltmeter	
5	Water gauge	
6	Fuel gauge	
7	Socket 12V	15A
8	Interior lighting	10A
9	Mooring light	10A
10	Navigation light	10A
11	Deck light	10A
12	Navigation	10A
13	Refrigeration unit	10A
14	Auxiliary	10A
15	Water unit	10A
16	Bilge pump	15A

## ■ GENERAL INFORMATION

### ELECTRICAL PANEL

The electrical switchboard does not require any routine maintenance. In case an electric appliance is not energized, check:

- The main power supply (batteries, battery switches).
- The switches and circuit breakers on the line.
- the relevant electrical unit.

## ■ ELECTRICAL CIRCUIT, 12 V

### GENERAL RECOMMENDATIONS

- Never work on a live electric fitting.
- The batteries must be strongly fastened.
- Do not block the battery ventilation ducts, some of them may give off hydrogen which represents a danger of explosion.
- The batteries must be handled with care. In the case of contact with electrolyte thoroughly rinse off the affected part of the body and consult a doctor.
- To avoid short-circuiting between the battery poles do not store conducting objects near to the batteries (metal tools, etc...).
- Turn off the electrical circuit with the battery switches when installing batteries or during their connection/disconnection.
- Never modify the specifications of power overload protection devices.
- Never modify an installation. Use the services of a qualified marine electricity technician.
- Never install or replace the electric appliances (or any electric equipment) by components exceeding the capacity (amperage) of the circuit (Watt for bulbs).
- Do not leave the vessel unattended when the electrical system is switched on .
- Certain lights represent a significant heat source, be careful of surrounding objects.

Note that the 12 V circuit wires are red for positive and black for negative.



### DANGER

- There may be danger of fire or explosion if direct current systems are incorrectly used.



### WARNING

- Handle the batteries with care (Please refer to the manufacturer's instructions).
- In case of electrolyte splashing, thoroughly rinse the part of the body that has been in contact with it. Obtain medical advice.



### PIECE OF ADVICE - RECOMMENDATION

- Keep the batteries clean and dry in order to avoid premature wear.
- Periodically check the electrolyte level. Add distilled water when needed.
- Tighten and maintain the terminal connectors by greasing them regularly.
- Disconnect the batteries during winter storage or long periods of inactivity.



## Synoptic - 12 V

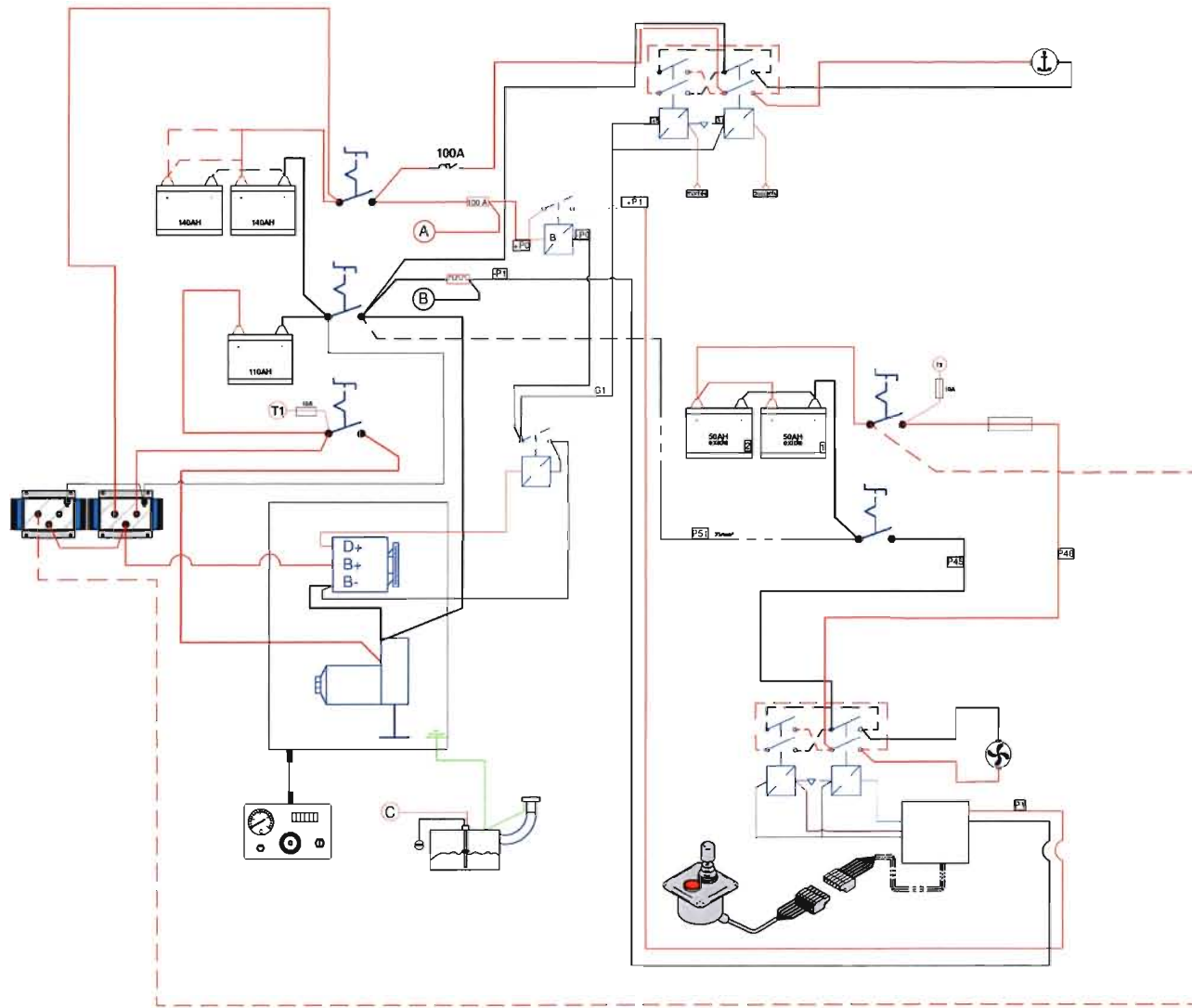

# Electrical equipment 9

## BOW THRUSTER 12V LAY OUT OF

### Elements - Forward cabin



1. Battery set (2 x 50A)
2. 315A fuse
3. Engine 12V
4. Battery switch - Positive
5. Battery switch of negative terminal

### Nozzle



### OPERATION Control - Starboard wheelhouse



### Electric winch

Lay out of: Cockpit



### Breaker

Lay out of: Starboard aft cabin



Winches great sailing: 100A

Winches - Genoa: 125A



### WARNING

-Refer to the manufacturer's instructions for use and maintenance.

## CIRCUIT BREAKERS

Lay out of - Chart table unit



Circuit breakers are resettable.  
Press the tab manually on black back on the road circuit.

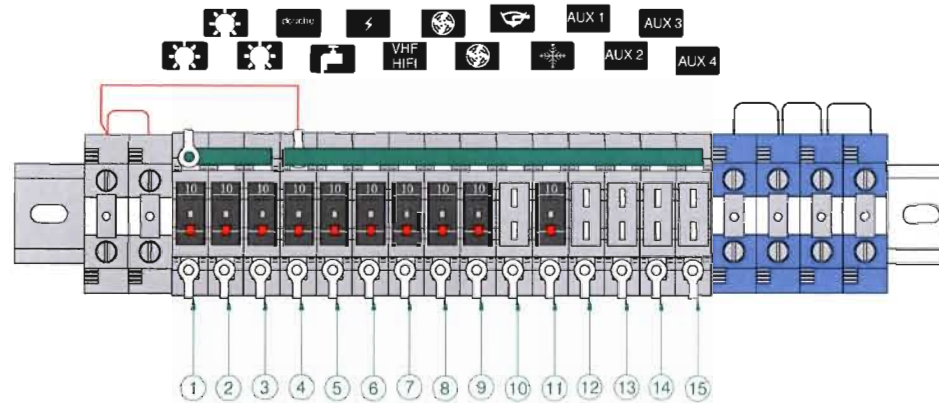

1. Interior lighting
2. Interior lighting
3. Interior lighting
4. Draining pump for shower
5. Water unit
6. 12 V socket
7. VHF - Hifi
8. Ventilator
9. Ventilator
10. Electric bilge pump
11. Refrigeration unit
12. Fridge
13. Available
14. Available
15. Available

Lay out of: Starboard aft cabin

1. SHUNT (used to measure current)
2. 100A fuse (Positive mains circuit 12V)



FUSE - WATER GAUGE

Lay out of: Tank



# Electrical equipment 9

## BATTERY SWITCH

Lay out of: Starboard aft cabin

1. Battery switch - Common negative
2. Battery switch - Positive engine
3. Battery switch - Service positive



## BATTERIES

Lay out of: Starboard aft cabin

- Service battery 140A  
Additional service batteries 140A



Engine battery 110A

Lay out of: Under the companionway

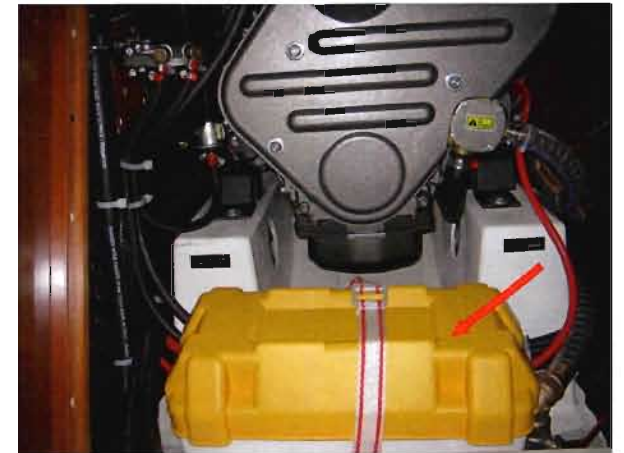



## BATTERIES

Battery charging is achieved through the alternator coupled to the engine or through use of the 220 V shore charger. Keep the batteries charged enough (essential to ensure them a correct service life).

Make the most of time alongside to use the 220 V shore charger so as to start out sailing with fully charged batteries. Always check the battery and charge system condition before you put out to sea.

## BATTERY SWITCH

The electricity onboard is 12 V DC.

The electrical system consists of service batteries.

The batteries supply power to all the functions on board.

The engine has its own battery.

Provide electricity to the system by turning on the positive and negative battery switches.

### BATTERY CHARGER 40A

Lay out of: Starboard aft cabin



### Control

Lay out of: Electrical panel



## WARNING

- Never work on a live electric fitting.
- Do not touch the battery terminals, danger of electric shock.



## PRECAUTION

- Switch off the electrical system with the battery switches when the boat is unattended.
- Never leave the vessel unattended with the mains electricity switched on.
- Turn off the electrical system with the battery switches and circuit breakers before gaining access to the rear of the electrical panels.
- Check the level of maintainable lead batteries.



## PIECE OF ADVICE - RECOMMENDATION

- It is recommended that you switch off all electrical devices before turning off the battery switches.

# Electrical equipment 9

## SHORE POWER SOCKET



Decomposed switch 40A -  
Chart table unit



Shore power socket 220V - 30A  
(Landmark 1)



Bipolar circuit breaker 32A  
(Landmark 2)

## ■ ELECTRICAL CIRCUIT, 110-220 V

### GENERAL RECOMMENDATIONS

Certain vessels are equipped (as either standard or optional features depending on the model) with a 110 V or 230 V circuit.

The following measures are recommended in order to avoid the danger of electrical shock and fire:

- Never work on a live electric fitting.
- Plug in the boat/shore supply cable on board before plugging into the shore supply socket.
- Never let the end of the boat/shore supply cable hang in the water.
- Turn off the shore supply with the onboard cut-off device before connecting or disconnecting the vessel/shore supply line.
- Disconnect the vessel/shore supply line at the shore socket first.
- Check the polarity indicator for the shore connections (110V AC version).
- If the reverse polarity indicator is activated immediately disconnect the line. Rectify the polarity fault before using the vessel's electrical installation.
- Close the shore supply input cover firmly after use.
- Do not modify the vessel/shore supply line connections; only use compatible connections.
- Do not alter the vessel's electrical system. The installation, modifications and maintenance must be carried out by a qualified marine electricity technician. Check the system at least twice a year.
- Disconnect the vessel supply when the system is not being used. This is to prevent the danger of fire.
- Use electrical appliances with a double insulation or earthing.

Note that the live wires are brown, the neutral ones are blue and the earth wires are green and yellow.



### DANGER

- Never let the end of the boat/shore supply cable hang in the water. The result may be an electric field liable to hurt or kill the swimmers nearby.
- There may be danger of electrocution if alternating current systems are incorrectly used.



### PRECAUTION

- Never modify an electric fitting and relevant diagrams yourself.
- Call in a technician skilled in marine electricity to carry out any electric modification.
- Never change the breaking capacity (amperage) of the overcurrent safety devices.
- Never install or replace the electric appliances (or any electric equipment) by components exceeding the capacity (amperage) of the circuit (Watt for bulbs).



### PIECE OF ADVICE - RECOMMENDATION

- In order to reduce the risks of electric shock and fire:
- Before you plug in or unplug the boat/shore supply cable, switch off the shut off device connected to the shore supply.
- Plug in the boat/shore supply cable in the boat before you plug it into the shore supply socket.
- Unplug the boat/shore supply cable on shore first. Close the shore socket cover.
- Do not modify the connections of the boat/shore supply cable



## Electrical equipment 9

### ELEMENTS 220V

#### Water heater

##### Lay out of: Starboard saloon

1. Thermostatic mixer valve
2. 220 V socket
3. 25l water heater



#### Television

##### Lay out of: Starboard aft cabin

1. 30A breaker
2. Inverter 12/220V



POSITION OF ELEMENTS



# Electrical equipment 9

## ELEMENTS

220V shore power  
(Landmark 1)



Breaker  
(Landmark 2)



Relay box + Differential  
(Landmark 3)



Drainage - Sea water  
Compressor - Aft cabin  
(Landmark 4)



Drainage - Sea water  
Compressor - Saloon  
(Landmark 5)



Seawater inlet + Filter +  
Seawater pump  
(Landmark 6)



Maintenance of filters (to engage in regular):

- Close valves taken seawater.
- Unscrew the top of the filter.
- Clean the strainer.
- Back all.

Compressor - Saloon  
(Landmark 7)



Outlet



Operation:

- Turn on the circuit 220V (dock or generator).
- Open the inlet valves seawater.
- Choose the temperature using the control boxes.



**WARNING**

-Refer to the manufacturer's manual given with your boat.



## ■ EQUIPMENT

### GENERAL INTRODUCTION

(As far as possible) use electric appliances with double insulation or with three conductors (Neutral-Live wire-Ground).

### ELECTRONIC

Wire runs are available to complete the boat equipment.

Do not install electronic instruments or repeaters less than 1,50 m away from the radio loudspeakers.

**ADVICE:** *For further information refer to the appliance instructions.*

### MAINTENANCE

Clean the repeater dials with freshwater. Refer to the instructions before using any other produce. The use of alcohol must be avoided.



### PIECE OF ADVICE - RECOMMENDATION

- Place the protective covers on the repeaters when unused for long periods.
- When sailing store the protective covers inside the boat to avoid losing them.
- The different repeater displays are back-lighted.
- The onboard radio is fitted with two outside speakers.
- When mooring be careful to adjust the sound so as not to disturb your neighbours !

# ELECTRONIC - TRANSDUCER LOCATION



View interior



View Outside





# Electrical equipment 9

## ELECTRONIC

### LEAD LINES

The log and depth sounder sensors are located under the forward cabin floor. Keep the log sensor cowl close to the instrument so as to be able to intervene in complete safety.

Do not store material on top of the sensors.

### AUTO PILOT

The pilot consists of several elements listed as follows:

- Repeater in the cockpit starboard side above the engine panel.
- Calculator, piston, hydraulic pump and rudder either side of the steering stock in the aft locker (access through one of the two cockpit lockers under the tiller seating).
- To supply power to all elements switch on the "Navigation" circuit breaker on the electrical panel.
- For use and maintenance of the material consult the manufacturer instructions.

### PILOT ELEMENTS

#### Piston

Acces:  
Port aft cabin



#### Calculator

Acces:  
Starboard aft cabin



#### Gyrocompass

Hanging locker - Starboard aft cabin



### MAINTENANCE

Clean the transducer probe during each dry dock and the log sensor regularly. Read the instructions for maintenance recommendations.

Refer to chapter 11 "Launching" for the precautions to be taken concerning the sensors during hoisting.



### PIECE OF ADVICE - RECOMMENDATION

- For best results, remove any metal compass.
- Do not store material close to the calculator and electrical connections.



### HEATING - POSITION OF ELEMENTS

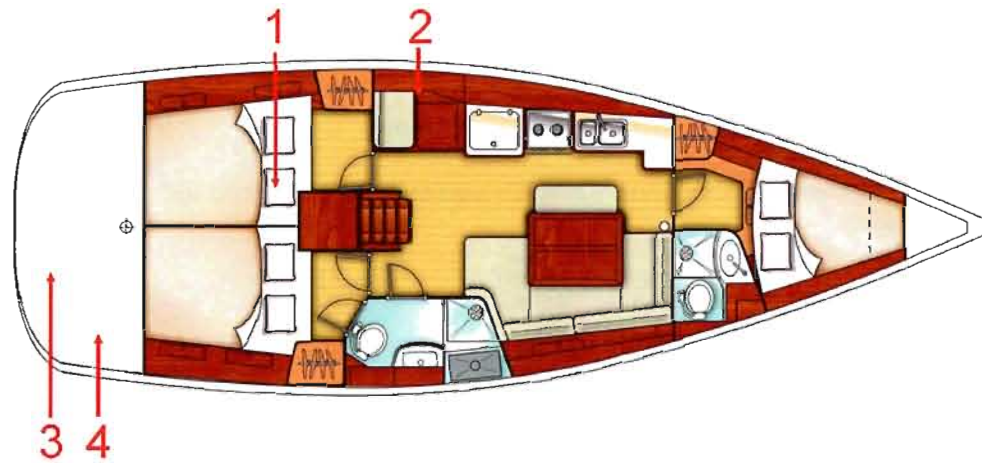

Supply - Diesel  
(Landmark 1)



Control  
(Landmark 2)



Diesel pump  
(Landmark 3)



Boiler  
(Landmark 4)



Outlet



#### WARNING

-Refer to the manufacturer's manual given with your boat.

# Engine

- General information
- Engine fitting

Lay out of -  
Port aft cabin



Deck filler



Gauge -  
Electrical panel



## ■ GENERAL INFORMATION

### TYPE OF MOTORISATION

Your vessel is fitted with an in-board diesel engine.

The transmission is of a shaftline type.

### PRECAUTIONS OF USE, OPERATING ADVICE

#### General point

- In this vessel, do not install an engine with a greater power and weight than that recommended, this will create a danger for its stability.
- Fuel which is stored elsewhere than in the fuel-tanks (portable tanks, jerrycans, etc...) must be kept in a ventilated space.
- Make sure that the engine compartment is clean and dry.
- Avoid contact between inflammable substances and the hot parts of the engine.
- Locate the extinguisher hole which allows access to the engine compartment if a fire should break out. (Refer to chapter 2).

#### Filling

Fill the fuel tank using the filler. In order to protect the deck from possible fuel splash, wet the area around the filler with sea water before you remove the filler cap. In case of splashing rinse the deck thoroughly (deck filler closed).

The fuel level is transmitted from the dipstick to the guage located on the house electrical panel.

Tank capacity - Diesel: 200 liter.



#### DANGER

- Stop the engine and refrain from smoking during fuel tank filling.
- Make sure that the ventilation openings in the engine (and generator, if installed) compartment are well cleared.



#### PRECAUTION

- Never run the engine when the boat is hauled out.



#### PRECAUTION

- Stop the engine before you open the companionway hatch and side hatches.
- In case of an intervention when the engine is running:
- Stay away from belts and hot or mobile parts.
- Be careful with full clothes, long hair, rings etc. (you may be caught).
- Wear appropriate clothes (gloves, caps etc.).



#### PIECE OF ADVICE - RECOMMENDATION

- Carefully read the engine instructions given with your boat.

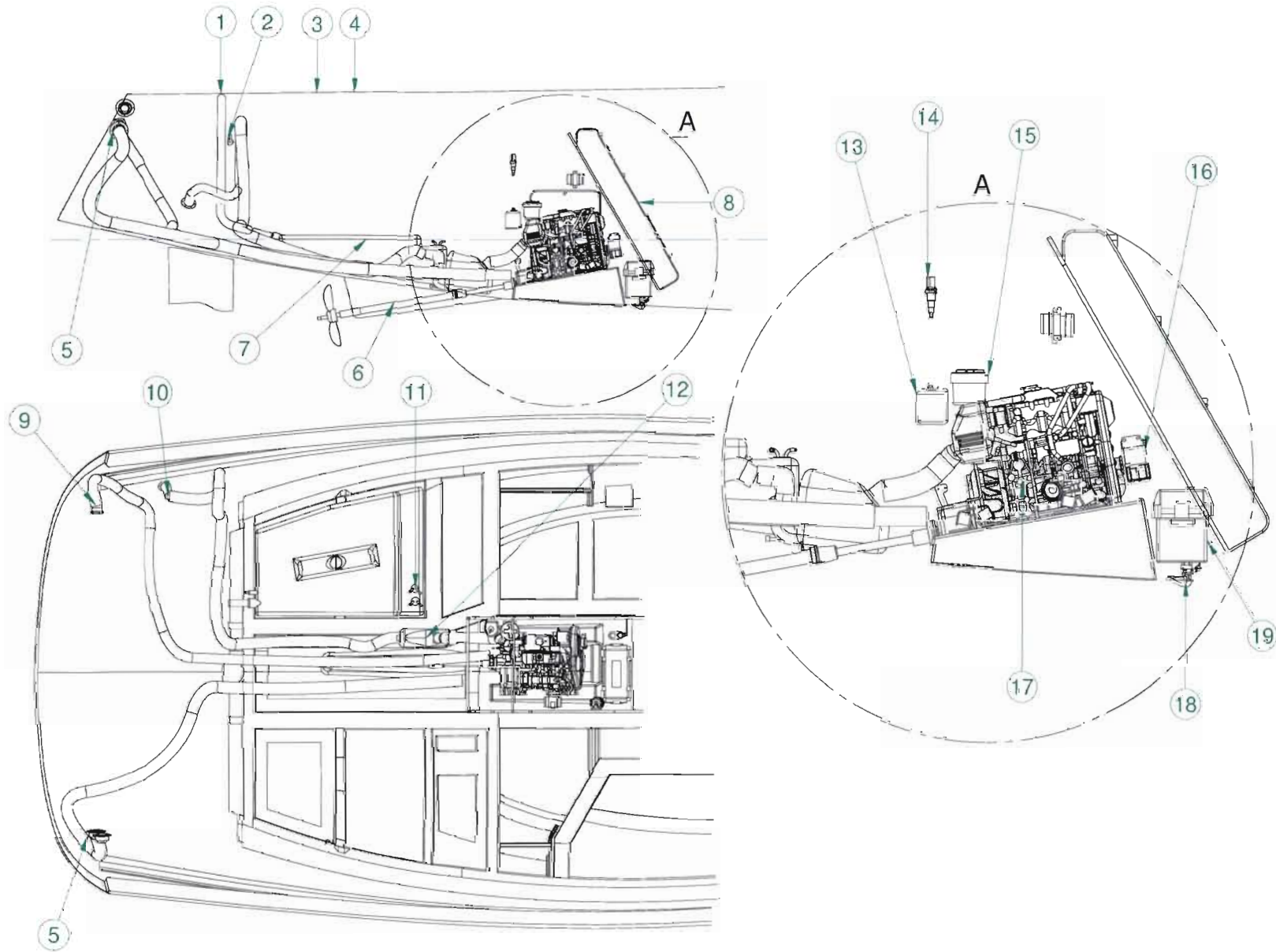

# Engine 10

REF	Designation
1	Filler cap
2	Vent hole
3	Engine control lever
4	Instrument panel
5	Fresh air inlet
6	Propeller shaft
7	Diesel tank - 200 l
8	Extinguisher access hole
9	Hot air extraction
10	Outlet
11	Supply valve - Diesel
12	Water trap
13	Accumulator tank
14	Anti-siphonage item
15	Sea water filter
16	Decanter valve
17	Engine
18	Sea water inlet valve for engine
19	Battery - 110A



## MAIN ELEMENTS OF THE ENGINE

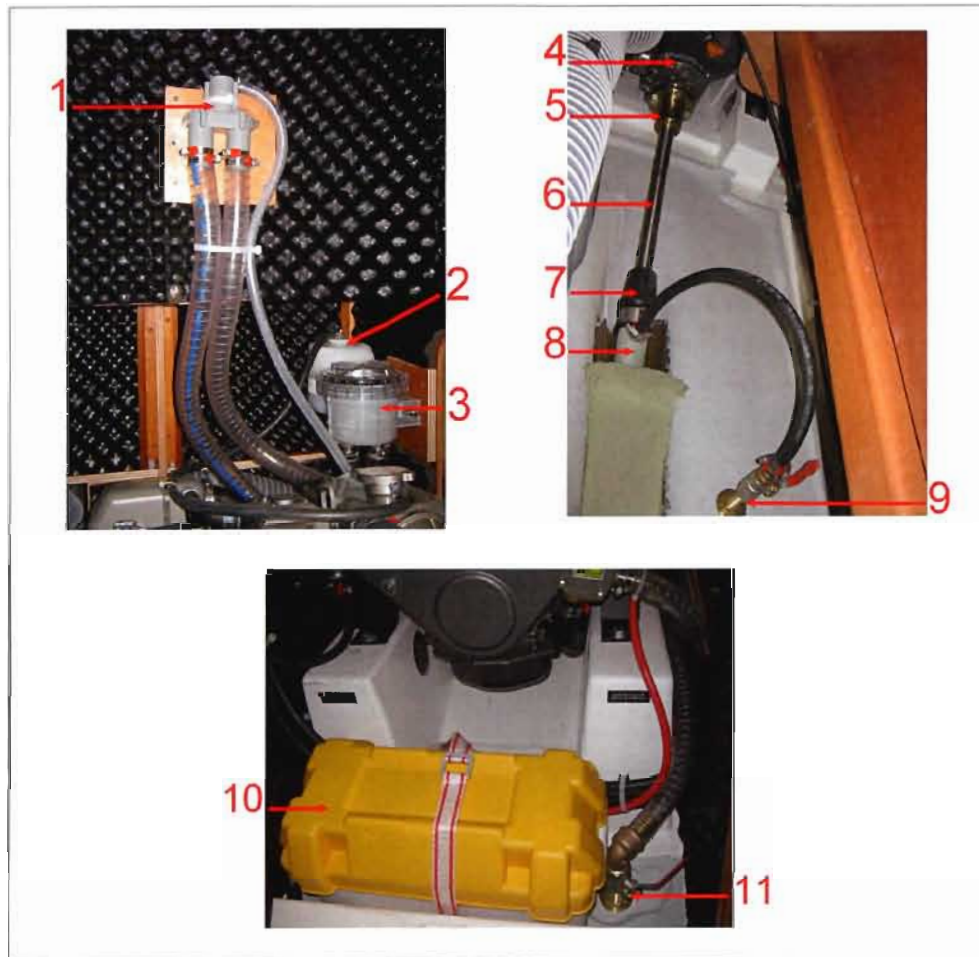

REF	Designation
1	Anti-siphonage item
2	Accumulator tank
3	Sea water filter
4	Reverser
5	Flange
6	Propeller shaft
7	Stuffing box
8	Rudder port tube
9	Seawater inlet - Sternpost
10	Battery - 110A
11	Sea water inlet valve for engine



# Engine 10

## Engine

These instructions give detailed explanations on proper operation of the engine.

- Refill before the fuel tanks have almost run dry (the fuel system may be stopped for lack of fuel).
- Make sure you have enough fuel before sailing.

## Access to the engine

You have access to the engine via the companionway hatch.

You can check the main parts thanks to side hatches.

## Engine water valve

The water inlet valve of the engine is essential in the engine operation.

- Keep the strainer under the hull as clean as possible.
- Brush the strainer when the boat is careened.
- Do not cover the strainer with antifouling paint.

It is essential that this valve is open before the engine is started (danger of rapid wear and substantial damage to engine installation).

If water does not flow out:

- Stop the engine immediately.
- Check that the valve is open.

Close the water inlet valve if the boat is unattended for long.

Inspect and clean the water filter regularly.

## Engine operation

Before starting the engine:

- Turn on the fuel valve.
- Open the valve of the engine cooling system and the valve of the stuffing box (see stuffing box paragraph).
- Operate the battery switches and energize the electric system.
- Disengage the reverse gear (it will make the acceleration possible when in neutral).



### DANGER

- Always start the engine with the control lever in neutral.



### WARNING

- Never switch off or de-energize the electric system when the engine is running.
- Imperatively operate the stop pull handle (or button) before using the ignition key to switch off a diesel engine.



### WARNING

- Tanks nominal load capacity cannot be fully used based due to trim and boat loading. A 20% reserve should be kept.



### PIECE OF ADVICE - RECOMMENDATION

- Get used to checking immediately after starting the engine if water is expelled with the exhaust gases

SUPPLY VALVE FUEL + SEA WATER INLET VALVE FOR ENGINE

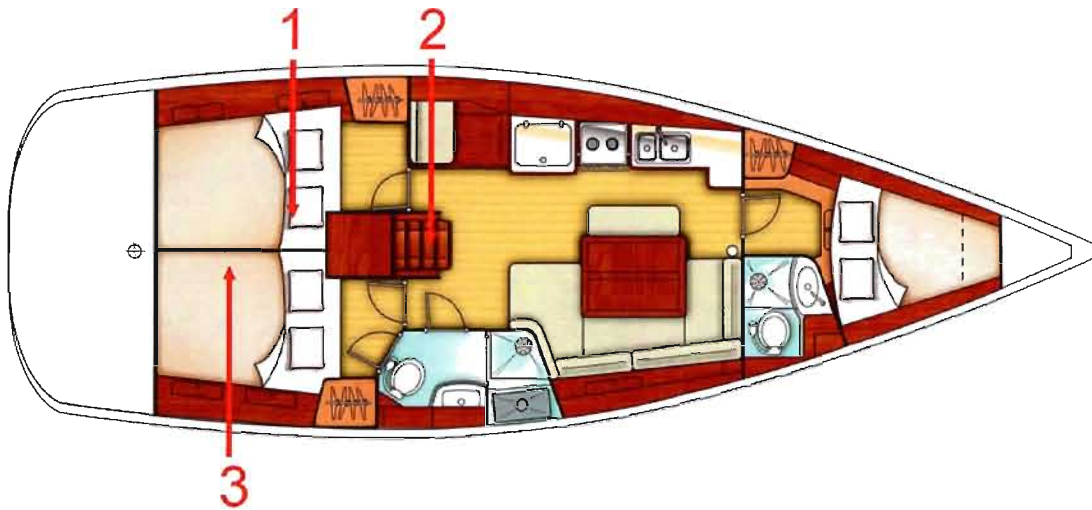

Supply valve  
(Landmark 1)



Engine water valve  
(Landmark 2)

View interior



Stuffing box



Seawater inlet - Stern frame  
(Landmark 3)

View interior



View Outside (Stuffing box)



## Fuel filter

The engine running problems may have different origins, among which dirty fuel. The injection pump may wear out if there is water in the system.

The water results either from the condensation resulting from an insufficiently filled tank, or from a filler cap either not closed properly or with a damaged seal.

In order to prevent any water infiltration, the fuel runs through two filters:

- One filter is an integral part of the engine, its role is to filter fuel very finely. To know when you have to intervene and how frequently you have to change it, please refer to the engine's manual.
- The second filter is on the pipe that links the tank to the engine, it plays the role of a water decanter and pre-filter.

Drain by undoing the knurled screw at the base of the decantation bowl (but not removing it).

Allow to flow into a box till the fuel looks clean.

Do it several times a year.

Change the pre-filter at least once a year (access to it when you remove the bowl).

As for the procedures in case of fire, refer to Chapter 2.

## Anode

- Check the whole propeller shaft several times a year.
- Regularly check the anode (on the driving shaft) for corrosion.
- Change the anode if necessary.
- Check and change the cutlass bearing if necessary.

## STUFFING BOX

The stuffing box can be reached through the service compartment in the starboard aft cabin.

Lubricate the seal every 200 running hours (or at least once a year).

Apply the grease the manufacturer recommends in his instructions.

After launching the boat, drive the air out from the sleeve pinching it with your fingers.



**DANGER**

- Never obstruct access to the fuel valve.

**Engine control**



REF	Designation
1	Engine panel
2	Engine control lever

**Engine panel detail**



REF	Designation
1	Tachometer Revolution counter
2	Control indicator lights
3	Pre-heating
4	Stop/start switch
5	12V socket

**Propeller detail**

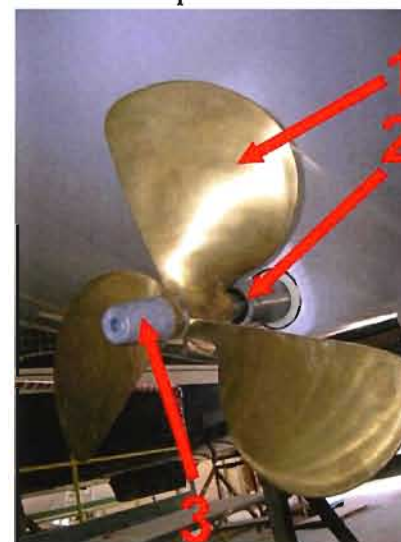

REF	Designation
1	Propeller
2	Hydrolube bush
3	Anode

## Engine 10

The instrument panel has all the testing functions of the engine and it does not require any special precaution (refer to engine leaflet).

Check the clutch and accelerator cables (lubricate the end fittings and forks).

### VISIBILITY FROM THE STEERING STATION

The international regulations to prevent collision at sea (COLREG) and the course regulations make mandatory a permanent and proper surveillance and the respect of priority.

Make sure there is no other boat on your way.

The visibility from the steering station may be obstructed in the following conditions:

- Speed.
- Position of the upper and side awnings.
- Boat heeling over, the sails reduce visibility under wind.
- Load and load distribution.
- Sea conditions, rain, spray, fog or darkness.
- Lights on inside the boat.
- Persons and removable equipments in the helmsman's field of visibility.



### PRECAUTION

- Do not change the propeller without specialist's advice.
- Regularly check the anode (at the end of the drive shaft) for corrosion, at least 2 times a year.



### PIECE OF ADVICE - RECOMMENDATION

- When the engine is running, avoid making noise and chops near the other users.
- Respect speed limits.
- In case this boat is equipped with a fix blades propeller, when sailing with a sailing speed over 8 knots it is essential to have the gear throttle on the neutral position.
- To start the engine again, reduce the speed of the boat when sailing (in order to be able to disengage the clutch before starting it again).



### PIECE OF ADVICE - RECOMMENDATION

- Check the whole propeller shaft several times a year.
- Change the anode if necessary.
- Check and change the cutlass bearing if necessary.





# Engine 10

## NAVIGATION: REMINDER OF SOME ADVICE

### Stability

During sailing keep all the portholes, windows and doors closed.

- The stability is reduced when you add weight in the upper parts.
- Stability may be reduced when towing a boat or when heavy weights are lifted with the davits.
- Breaking waves represent a serious danger for stability and for taking in water. Close the companionway doors and hatches in heavy seas.

### Prevention of manoverboard

Regularly check the guard-rails:

- With metal guard-rails, watch for corrosion particularly at connecting points.
- With synthetic guard-rails, change them as soon as they show signs of wear due to chafing or UV.

### Propeller

The propeller supplied as a standard with your boat is the result of tests carried out jointly with the engine manufacturer.



## PIECE OF ADVICE - RECOMMENDATION

- Have the whole driving and steering systems checked and maintained by a professional.
- Refer to the manufacturers' instructions supplied with your boat.
- Regularly check the O ring of the filler for good condition (in order to prevent water entries).
- Do not turn off the fuel tap after each use (except in case the boat is unattended for long).
- Keep the fuel tank as full as possible (to avoid condensation).
- Every year check the fuel system for condition (hose, valves, etc.).
- Have a professional to carry out the works on the damaged parts of the fuel system.
- Refer to the manufacturer's manual given with your boat.
- Be careful with any possible risk of oil and fuel spillage.





## Launching

- Launching recommendations
- Stepping the mast

POSITION OF HOISTING CRADLE AND STRAPS

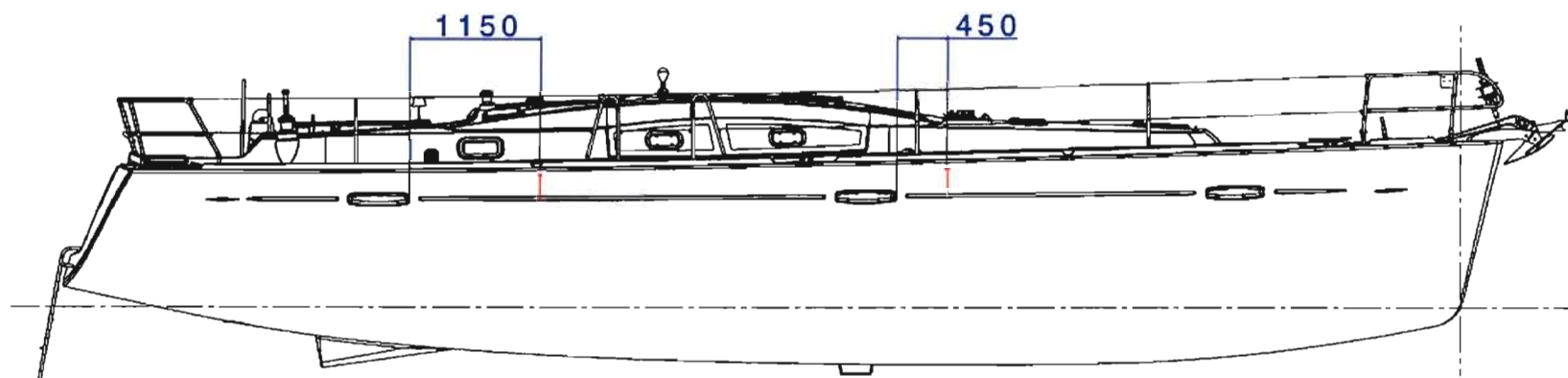

*NOTE: The measures are expressed in mm.*

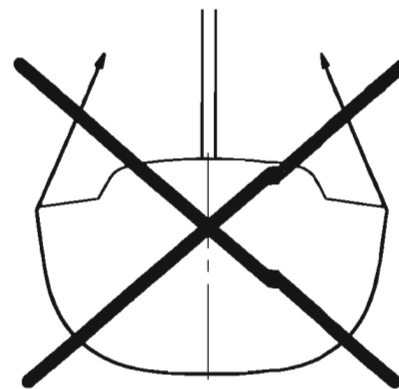
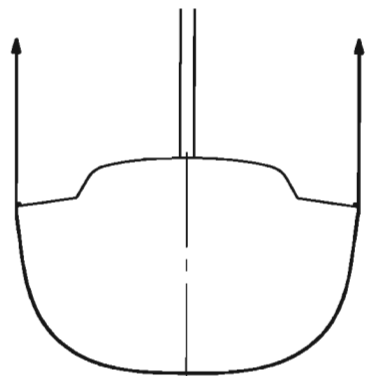

# Launching 11

## LAUNCHING RECOMMENDATIONS

A lot of skill and care is required to commission your BENETEAU boat. The proper working of all your boat equipments in the future results from the quality of the commissioning operations.

In order to remain completely under guarantee in the case of any failure of parts or materials the first launching and the first trials of different equipment must be carried out by your BENETEAU dealer.

If later you have to launch your boat yourself, you should take the following precautions:

### ■ BEFORE LAUNCHING

- If your boat is to be fitted with sounder and speedometer, allow for the relevant fittings and their installation.
- Check the water intake strain box for cleanliness.
- Check the engine and reduction gear oil levels (refer to engine manual).
- Turn off the engine cooling water drain valves .
- Retract the speedometer into its housing (it may be damaged by the handling belts).
- For the on-line engines, check the anode at the end of the shaft is in place. Check the nut tightening (the lock washer shall be turned over onto the nut). The anode shall not be painted.
- Turn off all the water inlet and drain valves (sink, washbasin, heads, engine).

### HANDLING

- Install a fore rope, a rear rope and fenders.
- When craning, check that no device is crushed by the belts (sounder, speedometer, shaft, etc.).
- Locate the strap positions using the stick-on markers. The belt position will be useful during the craning for a future launching.



### WARNING

- Do not stay on board or under the boat during hoisting.



### PIECE OF ADVICE - RECOMMENDATION

- The proper working of all your boat equipments in the future results from the quality of the commissioning operations.

#### **AFTER LAUNCHING**

- Check the sounder and speedometer fittings for tightness if need be.
- Open the valves and make sure that they are tight with the hull and relevant hose.

Before starting the engine, refer to chapter 10 "Engine".

#### **■ STEPPING THE MAST**

Please contact your dealer.

## Winter Storage

- Laying up
- Protection and maintenance





## ■ LAYING UP

- Take ashore all the ship's log, the ropes that are not used for mooring, the galley equipment, supplies, clothes, the safety equipment, batteries, the gas cylinder.
- Mark again the safety equipment, check the expiration dates, have the liferaft overhauled.
- Take advantage of this laying up to draw up a complete inventory of the equipment.

## ■ PROTECTION AND MAINTENANCE

### INSIDE

- Drain all the fresh water pipes and rinse them with water and vinegar (do not use a chlorine based product).
- Lubricate and close all the water inlet valves and thru-hull fittings. Rinse and completely drain the heads bowls and pumps.
- Retract the sounder and speedometer sensors.
- Installed in the square of a dehumidifier air leaving the cabin doors and open storage (cupboards, coolers).
- Leave the cushions outside for long before putting them back into the boat in the upright and side position in order to have minimum contact surfaces.
- During long absence leave the fridge and icebox doors open to avoid mould developing.

### OUTSIDE

- Thoroughly rinse the hull and deck.
- Grease all moving and mechanical parts (latches, hinges, locks, etc).
- Protect all ropes and mooring lines against chafing.
- Protect the boat to the highest degree with fenders.
- Make sure the boat is properly moored.
- Bring the removable cushions inside (washed with soapy water then dried) when the vessel is inoccupied.

All these recommendations do not make up an exhaustive list. Your dealer will give you the advice you need and will carry out the technical maintenance of your boat.



### PIECE OF ADVICE - RECOMMENDATION

- You alone know all the particularities of your boat and its equipment:
- To lay up your vessel carefully and methodically is the best guarantee to avoid problems when re-fitting out.
- All these recommendations do not make up an exhaustive list. Your dealer will give you the advice you need and will carry out the technical maintenance of your boat.
- Take advantage of this laying up to draw up a complete inventory of the equipment.



### **Engine**

The engine winterization shall be carried out by a professional. Depending on the boat location, afloat or ashore, winterization is different. Here are a few major tasks to carry out:

### **Afloat**

- Drain the cooling system and fill it with antifreeze.
- Shut off the battery switches, grease the terminals and check the battery voltage.
- Fill the fuel tanks to a maximum in order to avoid condensation.
- Please refer to the engine manual for anything relating to the engine.

### **Ashore**

- Take the batteries ashore and keep them on maintenance charge.
- Change the anode.
- Carry out the winterization operations specified by the manufacturer, keeping in mind that the freeze hazard is more significant when the boat is ashore.
- Slacken the a.c. generator and pump belts.

# Personal notes

Dealer stamp

The present document is not contractual and since we constantly desire to improve our models, we reserve the right to modify them without notice.

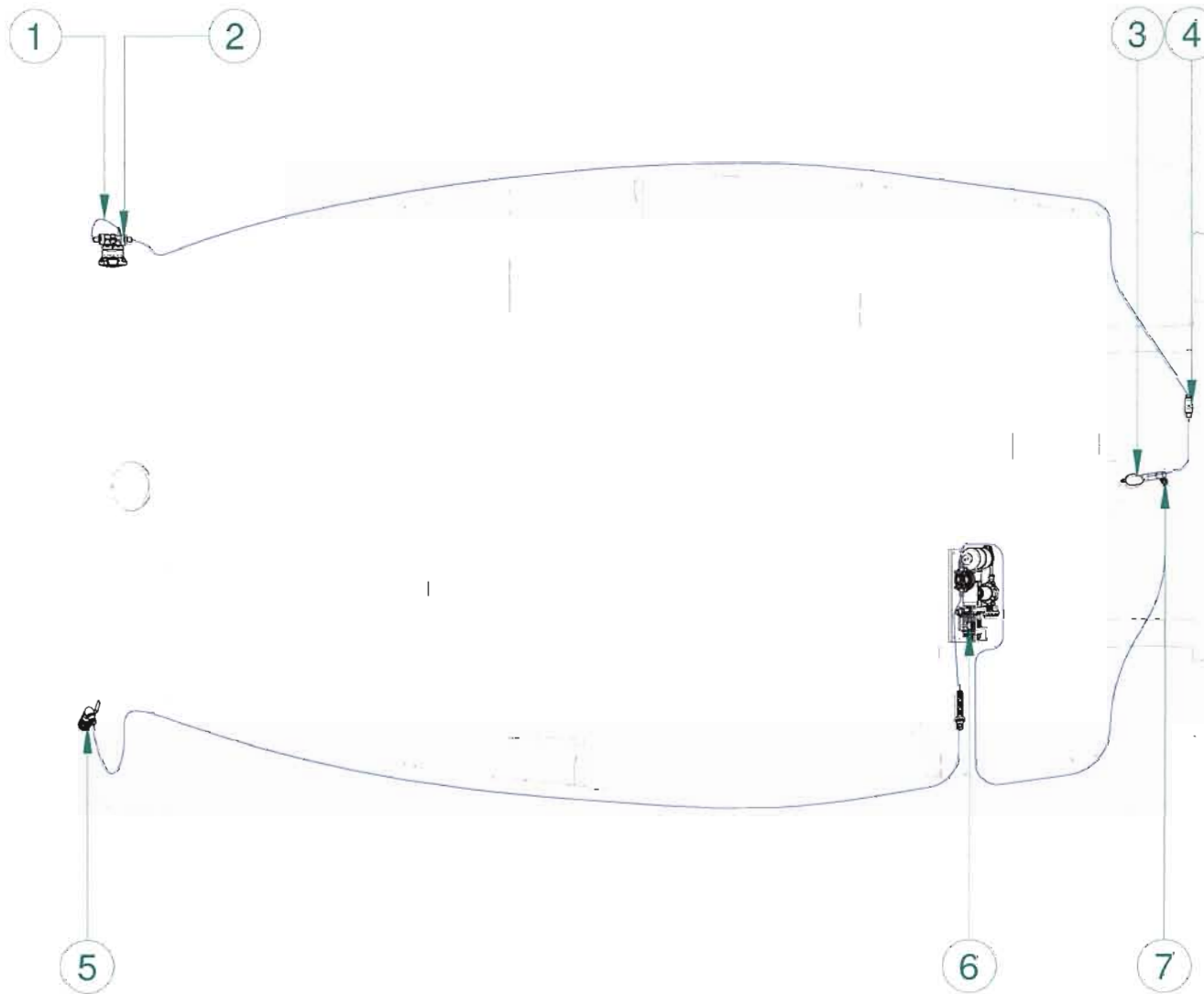

**BILGE DRAINING**

REFERENCE ON DIAGRAM	FUNCTIONS
1	Draining of manual bilge pump
2	Manual bilge pump
3	Stuffing box - Manual bilge pump
4	Non-return valve
5	Electric bilge pump draining
6	Electric bilge pump
7	Stuffing box - Electric bilge pump

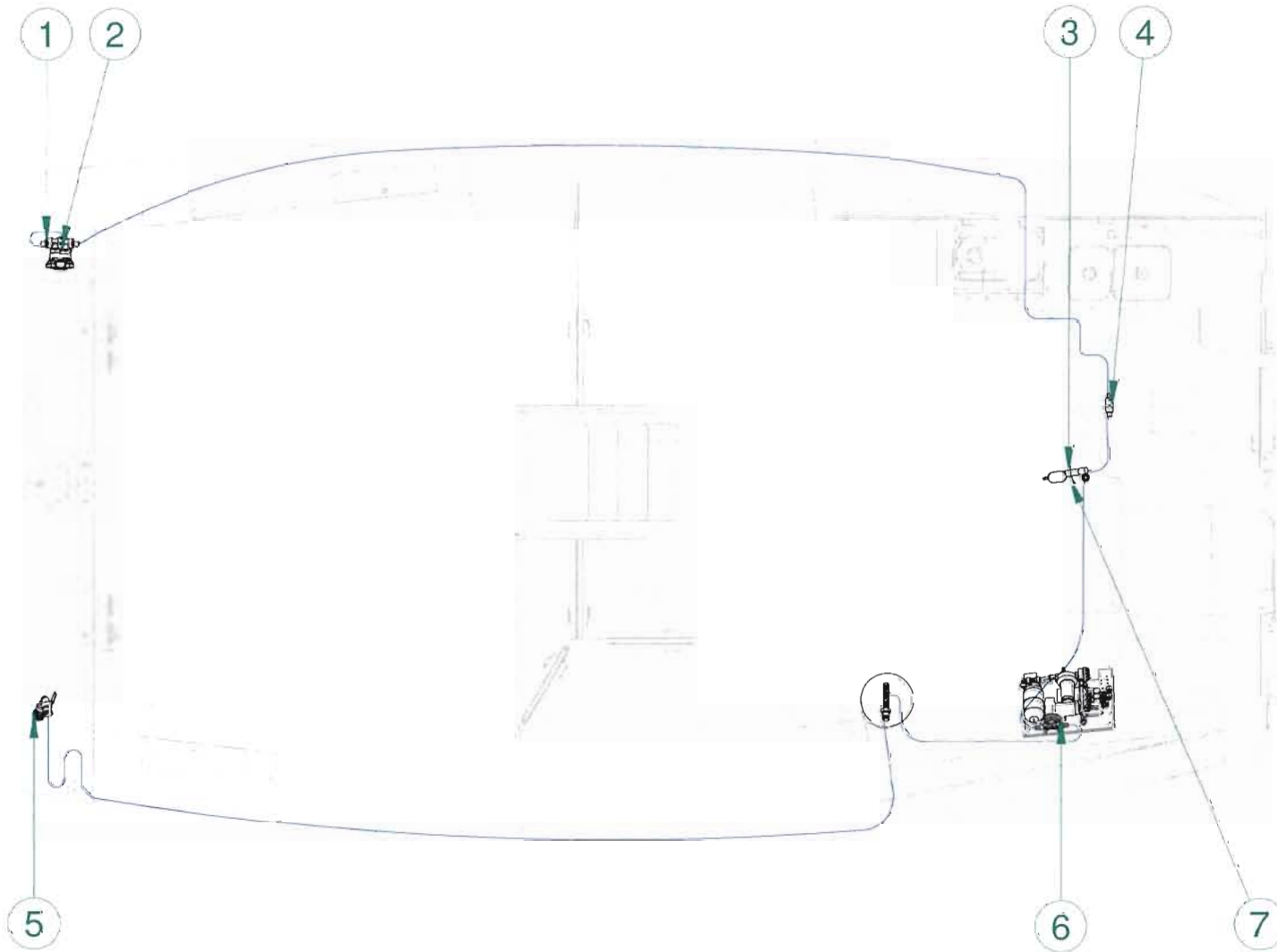



**BILGE DRAINING****CHARTER VERSION**

<b>REFERENCE ON DIAGRAM</b>	<b>FUNCTIONS</b>
1	Draining of manual bilge pump
2	Manual bilge pump
3	Stuffing box - Manual bilge pump
4	Non-return valve
5	Electric bilge pump draining
6	Electric bilge pump
7	Stuffing box - Electric bilge pump

3

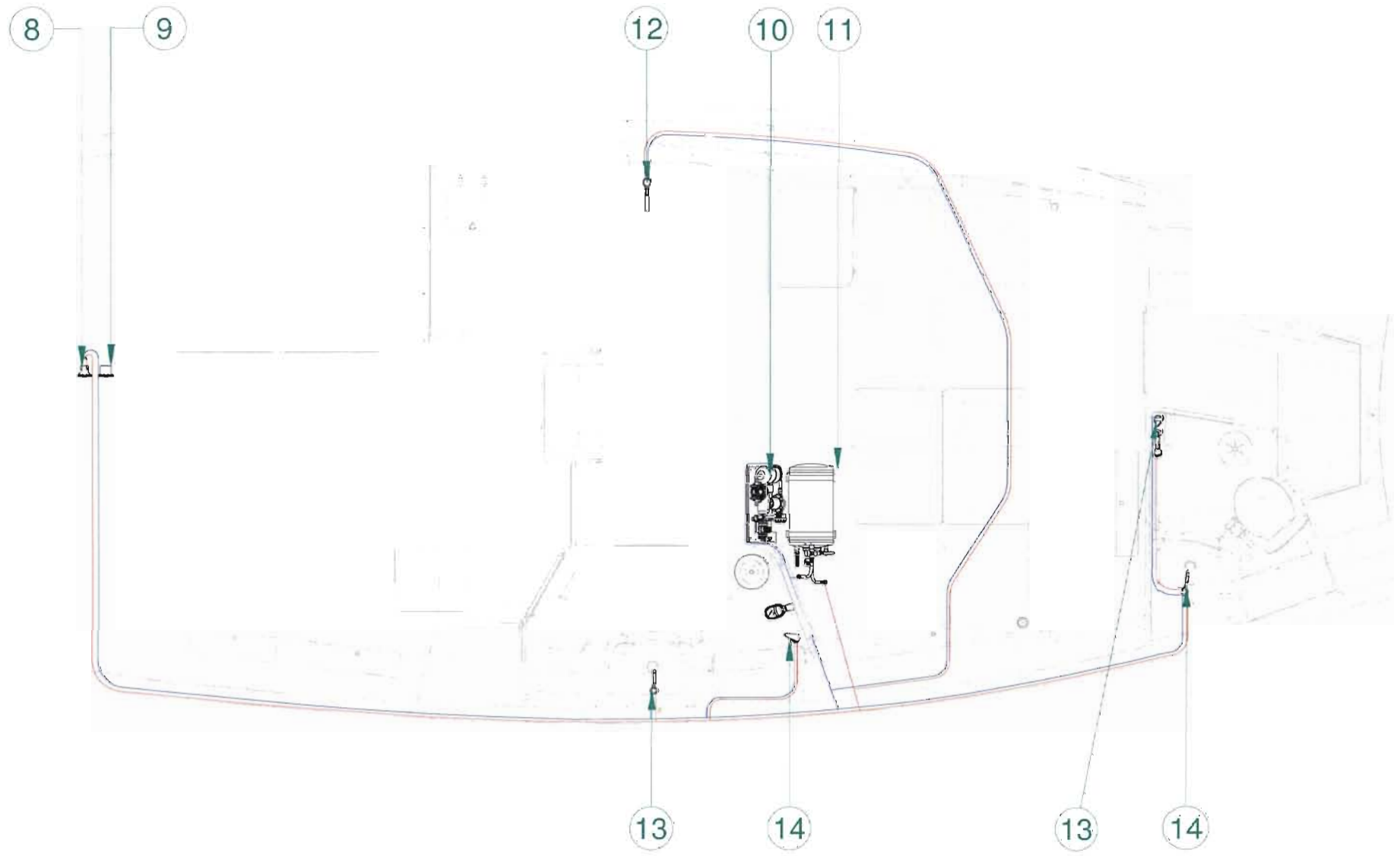

**DISTRIBUTION CIRCUIT****VERSION 2 CABIN**

<b>REFERENCE ON DIAGRAM</b>	<b>FUNCTIONS</b>
8	Cockpit shower spray
9	Mixer tap
10	Water unit + Accumulator tank
11	Water heater
12	Galley sink
13	Washbasin - Washroom
14	Shower

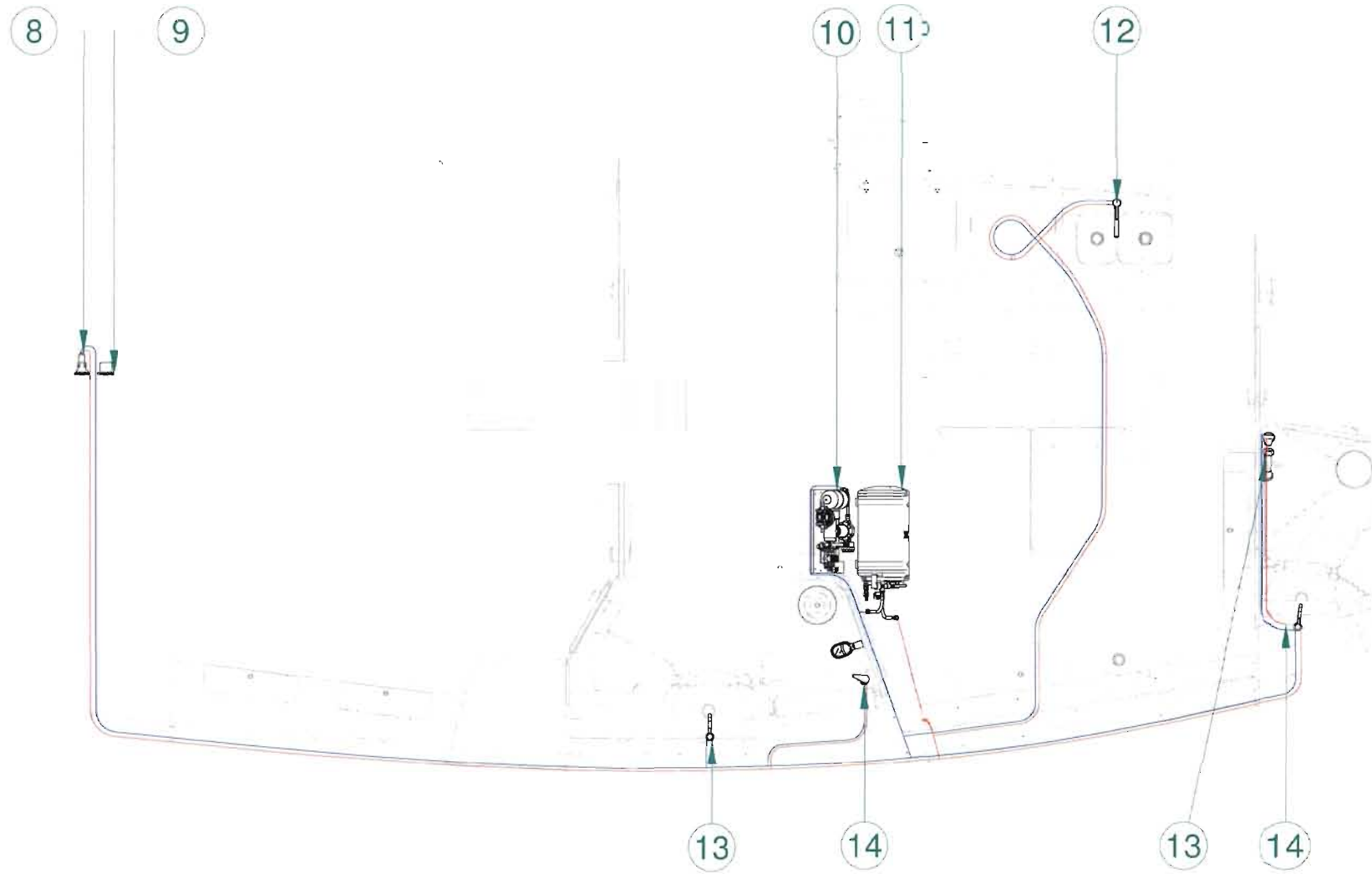

**DISTRIBUTION CIRCUIT****VERSION 3 CABIN**

REFERENCE ON DIAGRAM	FUNCTIONS
8	Cockpit shower spray
9	Mixer tap
10	Water unit + Accumulator tank
11	Water heater
12	Galley sink
13	Washbasin - Washroom
14	Shower

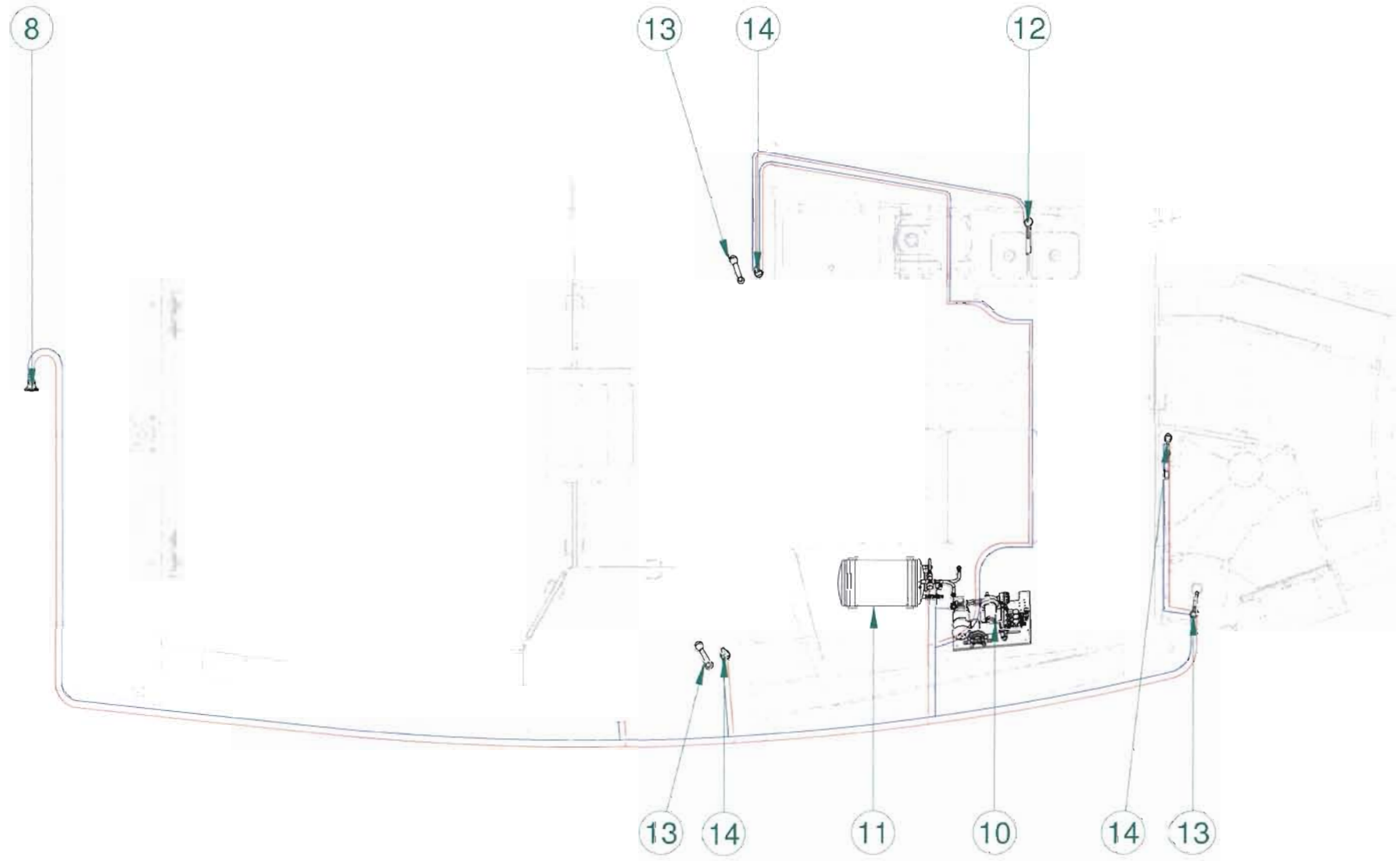

**DISTRIBUTION CIRCUIT****CHARTER VERSION**

<b>REFERENCE ON DIAGRAM</b>	<b>FUNCTIONS</b>
8	Cockpit shower spray
10	Water unit + Accumulator tank
11	Water heater
12	Galley sink
13	Washbasin - Washroom
14	Shower



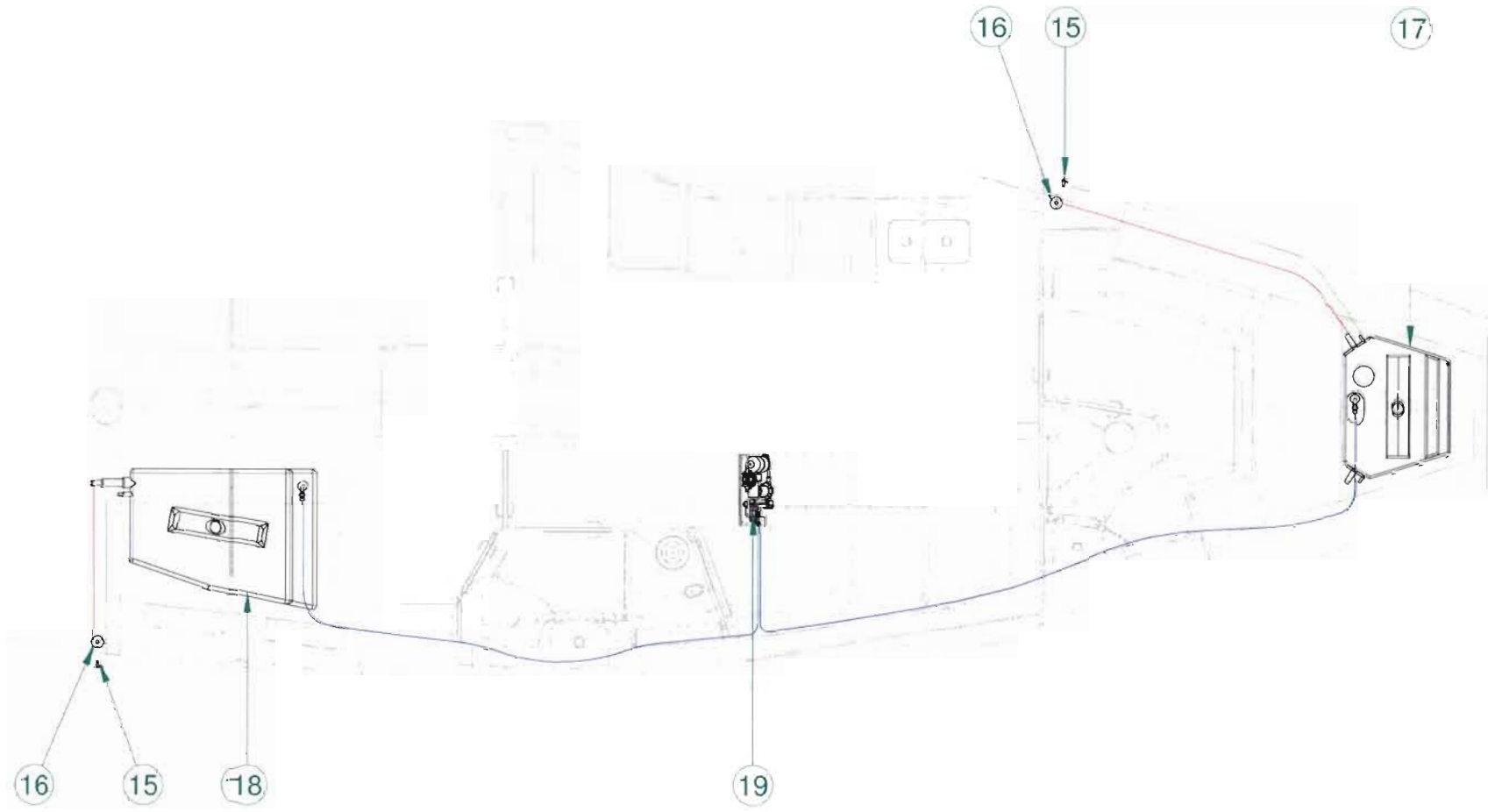

**FILLING CIRCUIT****2-3 CABINS**

REFERENCE ON DIAGRAM	FUNCTIONS
15	Vent hole
16	Deck filler
17	Forward tank
18	Aft tank
19	Tank supply valve

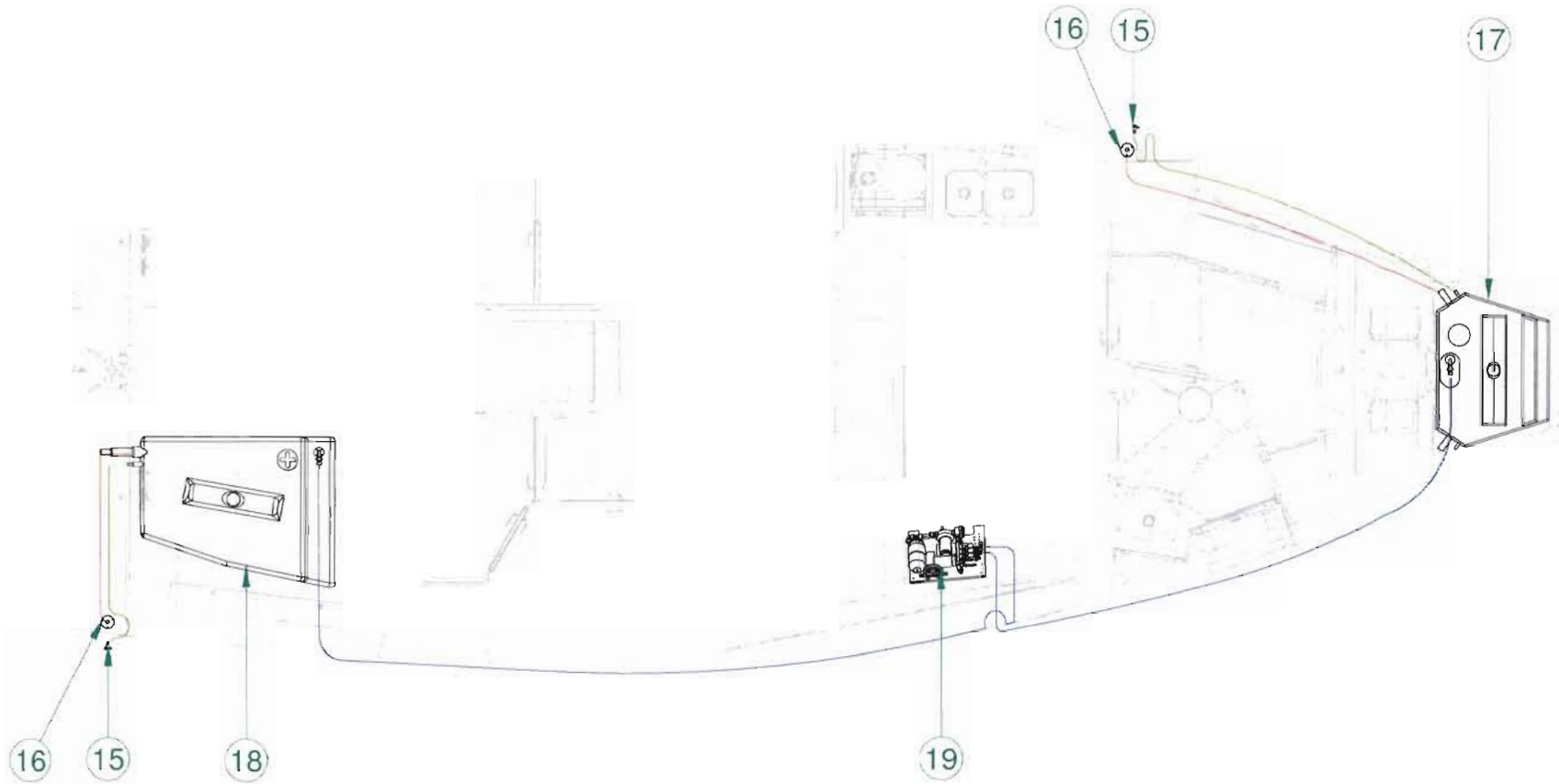

**FILLING CIRCUIT****CHARTER VERSION**

<b>REFERENCE ON DIAGRAM</b>	<b>FUNCTIONS</b>
15	Vent hole
16	Deck filler
17	Forward tank
18	Aft tank
19	Tank supply valve

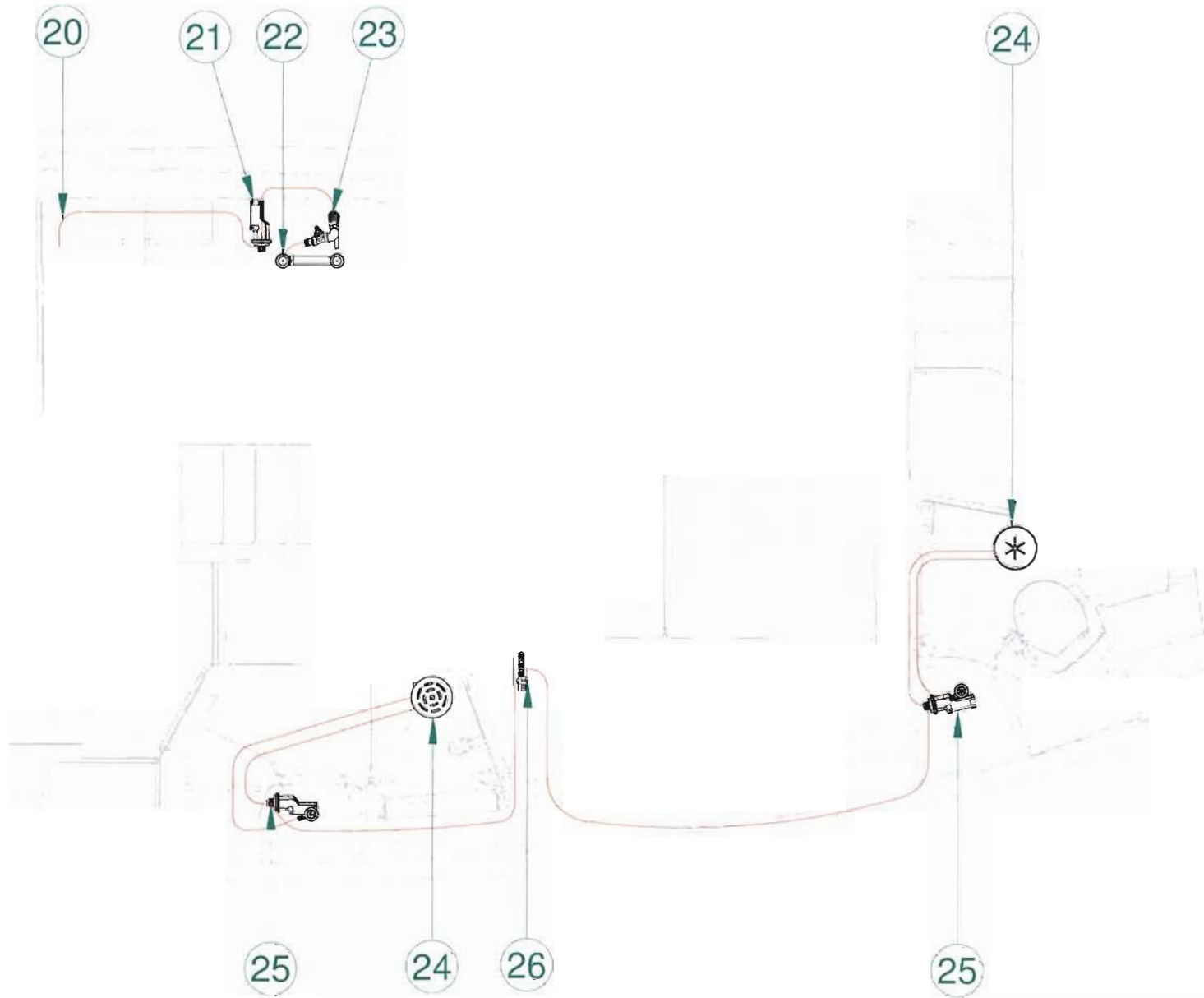

**SEWAGE CIRCUIT****VERSION 2 CABIN**

REFERENCE ON DIAGRAM	FUNCTIONS
20	Drain plug - Cool box
21	Pump - Icebox drainage
22	Sink plug hole
23	Sink draining + Cool box
24	Shower plug hole
25	Shower pump
26	Collector

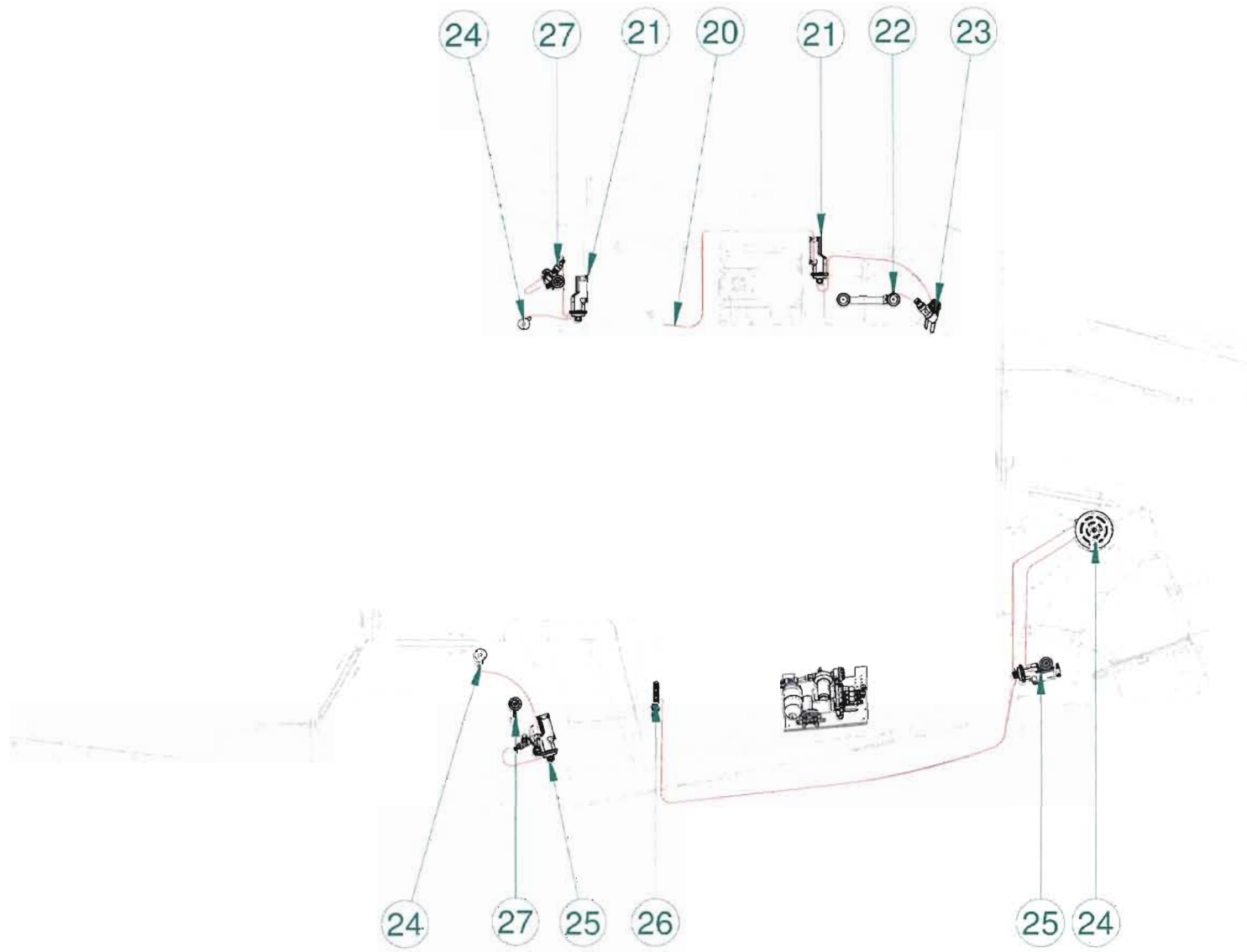



**SEWAGE CIRCUIT****VERSION 3 CABIN**

REFERENCE ON DIAGRAM	FUNCTIONS
20	Drain plug - Cool box
21	Pump - Icebox drainage
22	Sink plug hole
23	Sink draining + Cool box
24	Shower plug hole
25	Shower pump
26	Collector
27	Washbasin drain plug

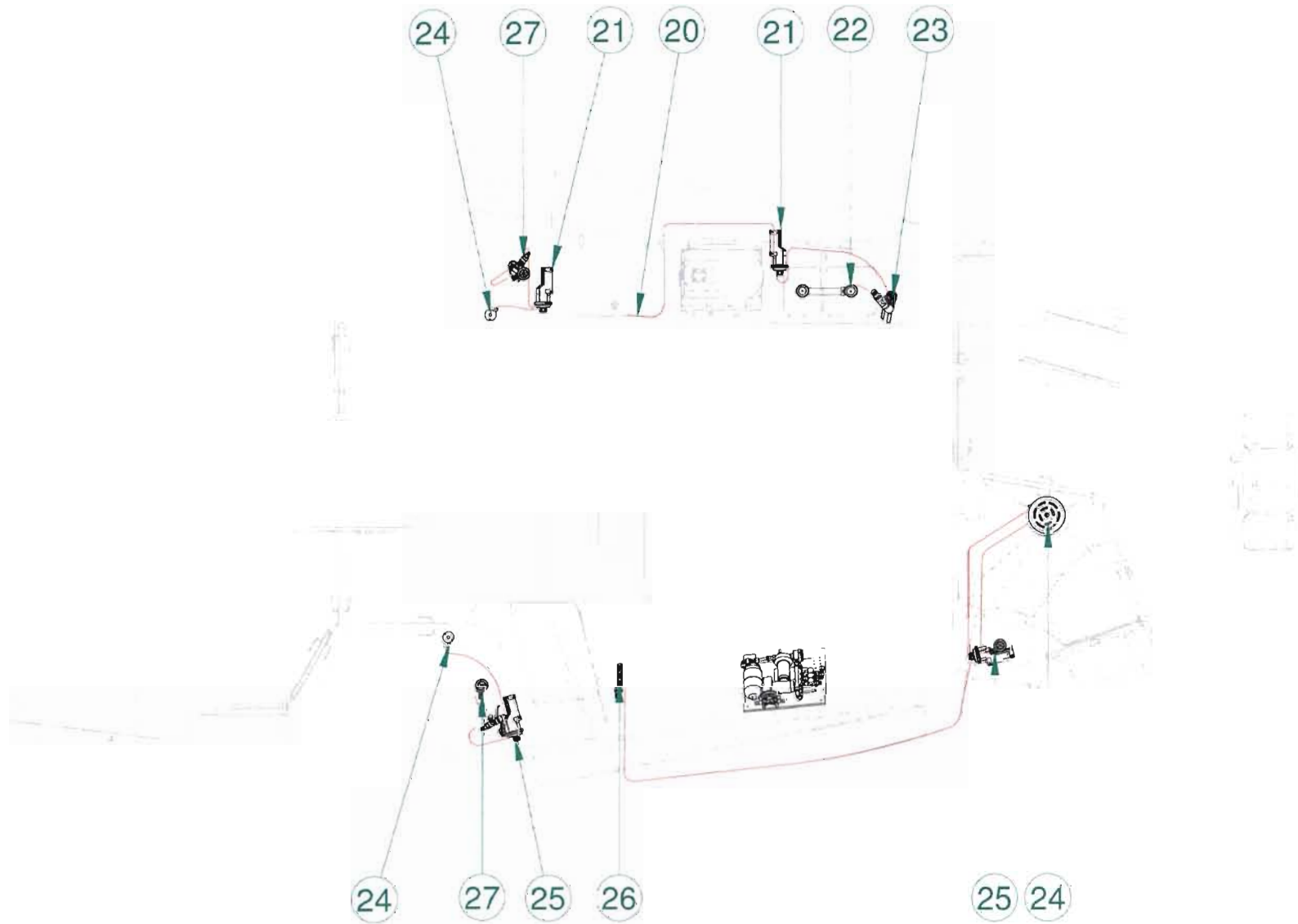

**SEWAGE CIRCUIT****CHARTER VERSION**

REFERENCE ON DIAGRAM	FUNCTIONS
20	Drain plug - Cool box
21	Pump - Icebox drainage
22	Sink plug hole
23	Sink draining + Cool box
24	Shower plug hole
25	Shower pump
26	Collector
27	Washbasin drain plug

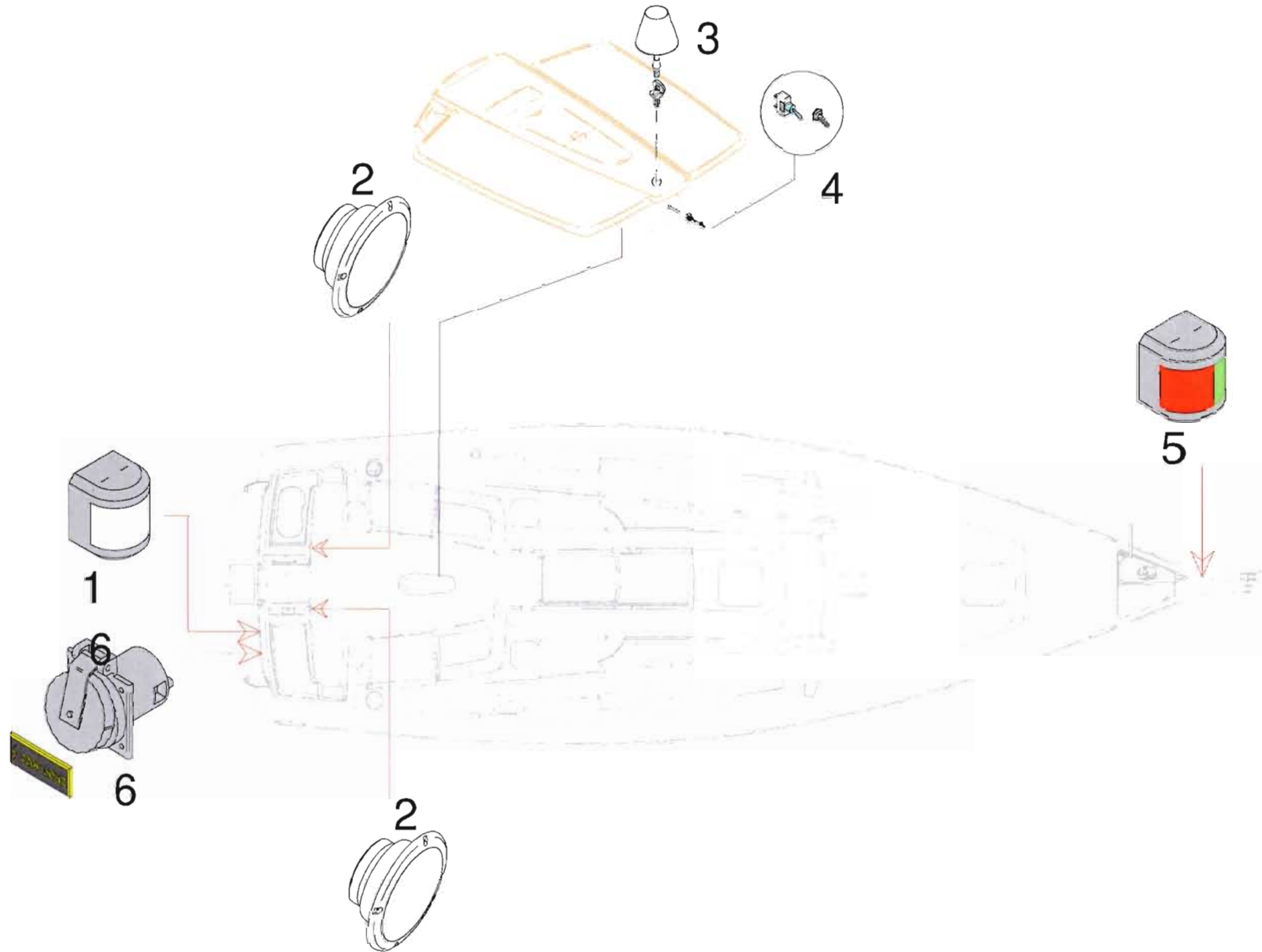

**NAVIGATION LIGHTS**

REFERENCE ON DIAGRAM	FUNCTIONS
1	Mooring light
2	Loudspeaker
3	Lampshade
4	Switch - Lampshade
5	Navigation light
6	220 V shore power

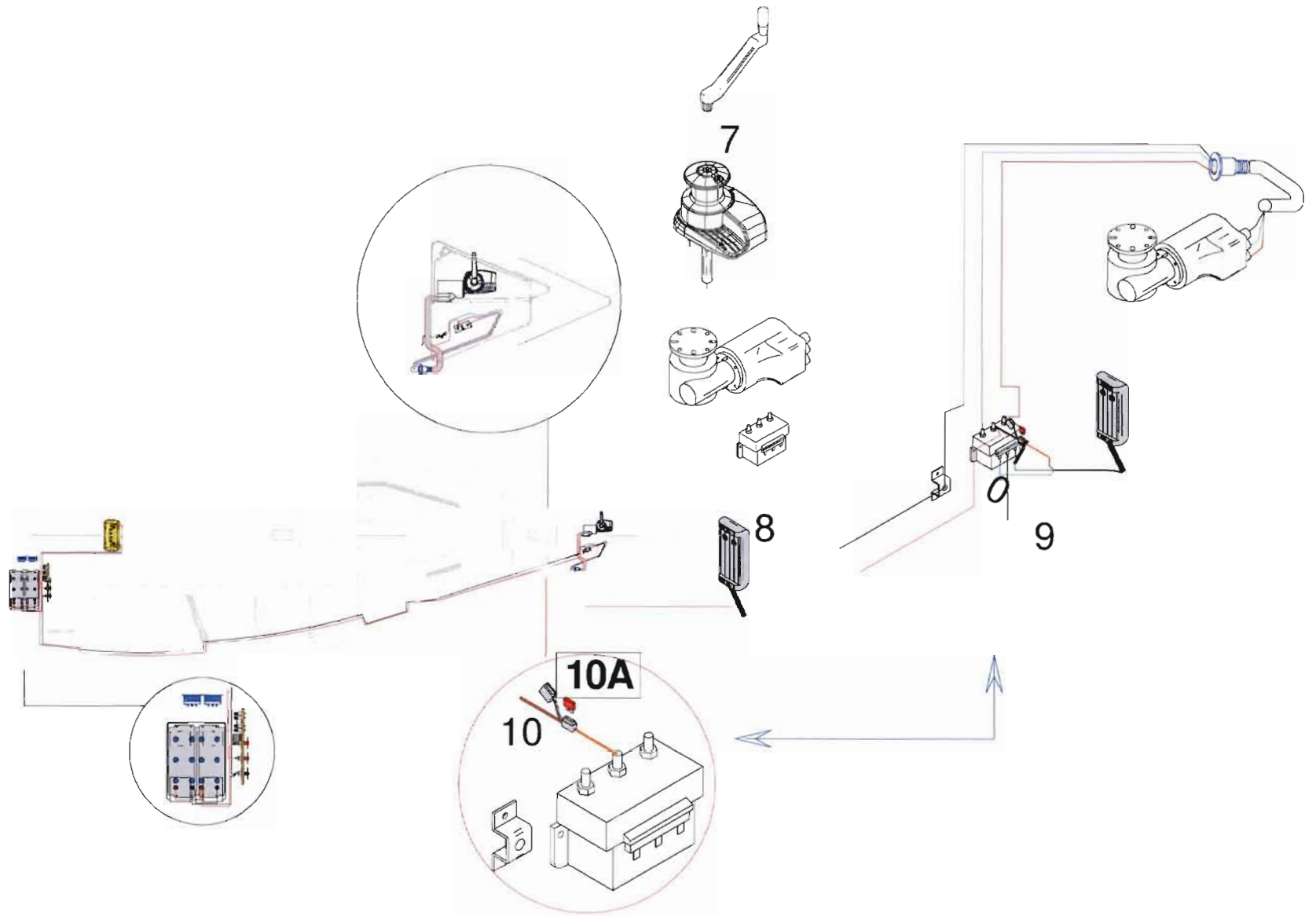

**LAY OUT OF - WINDLASS**

REFERENCE ON DIAGRAM	FUNCTIONS
7	Windlass 12V 1000W
8	Remote control
9	Relay box
10	10A fuse

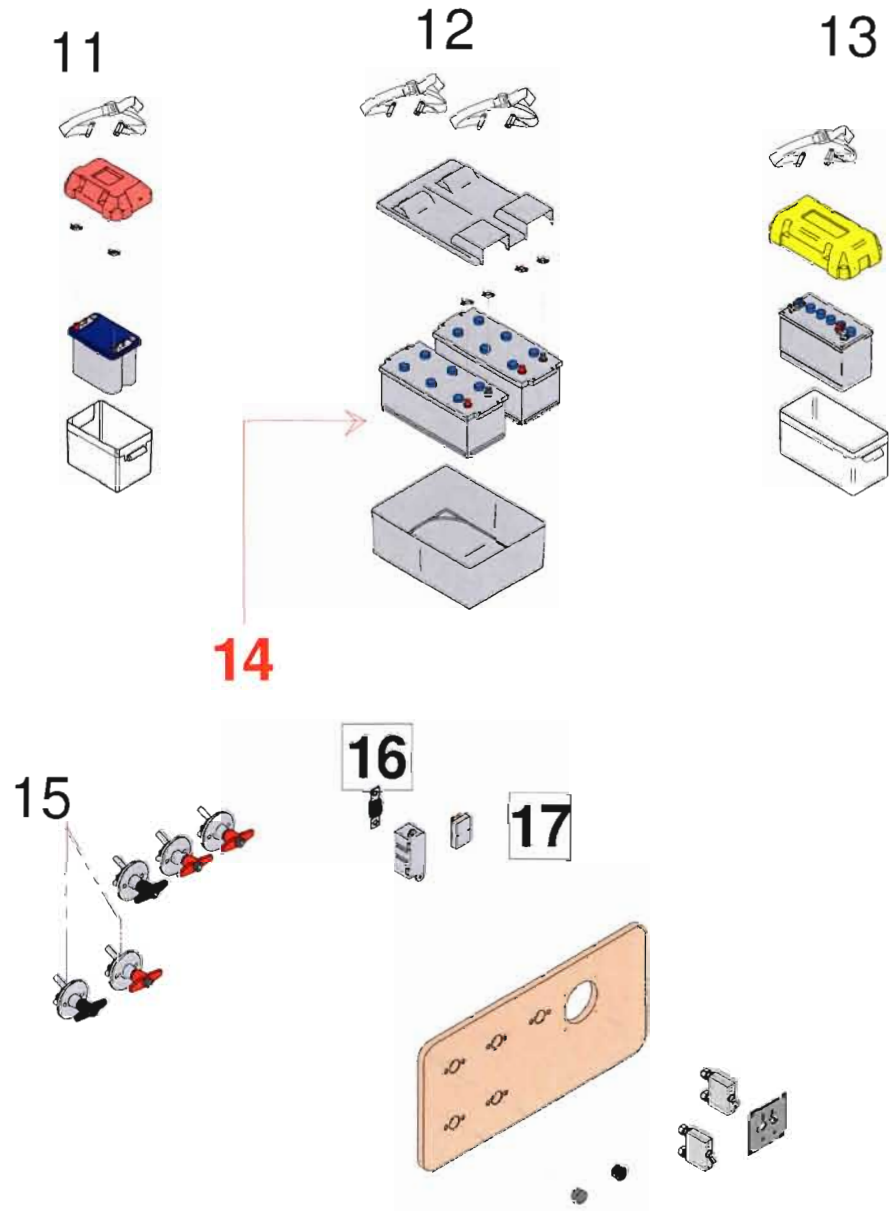



**BATTERY ISOLATION SWITCH SET**

REFERENCE ON DIAGRAM	FUNCTIONS
11	Bow thruster batteries 2 x 50A
12	Service battery 140A
13	Engine battery 110A
14	Additional service batteries 140A
15	Battery switch - Generator
16	General fuse - 12V - 100A system
17	SHUNT 100A

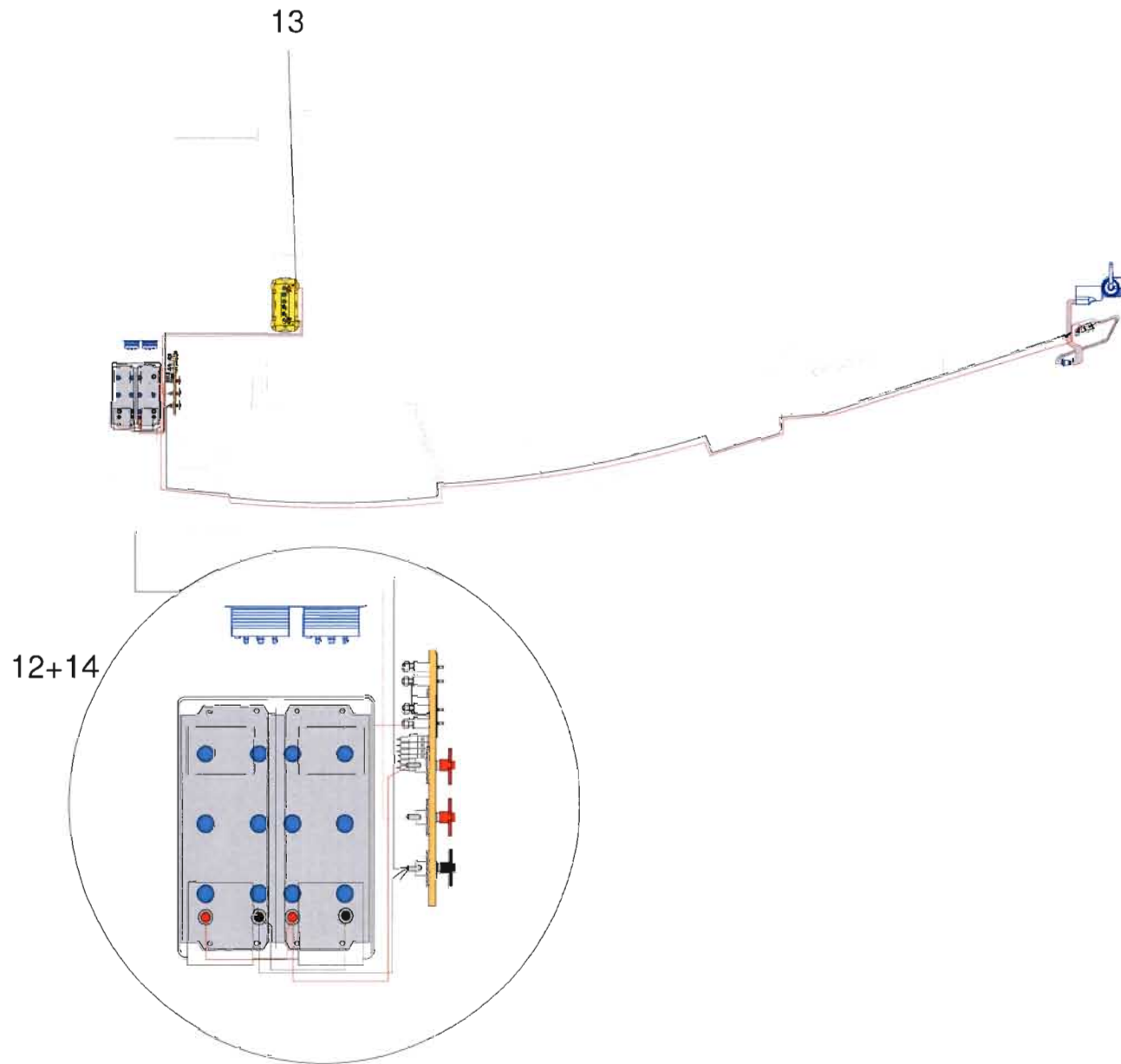

**BATTERIES INSTALLATION**

REFERENCE ON DIAGRAM	FUNCTIONS
12	Service battery 140A
13	Engine battery 110A
14	Additional service batteries 140A

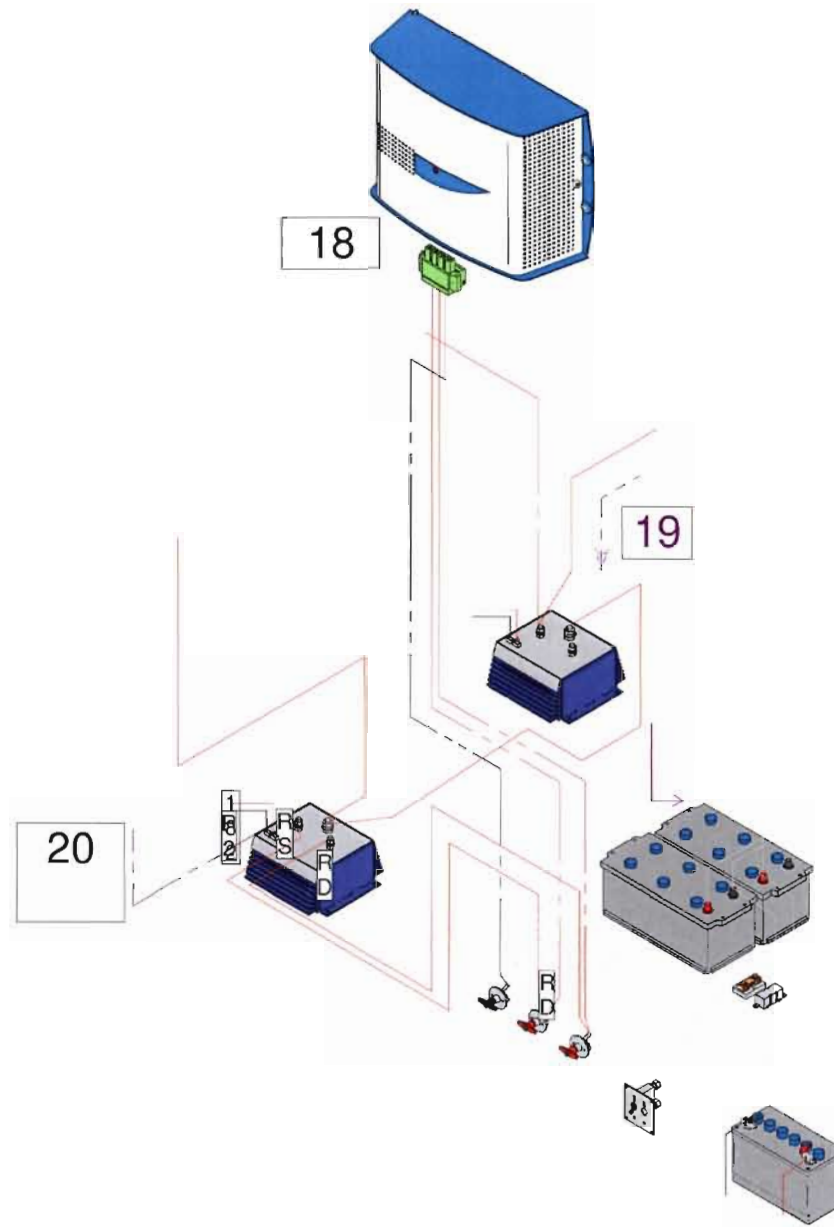

**CHARGE CIRCUIT 12V**

REFERENCE ON DIAGRAM	FUNCTIONS
18	Battery charger 25A / 40A
19	Charge divider (Optional equipment Bow thruster)
20	Charge divider

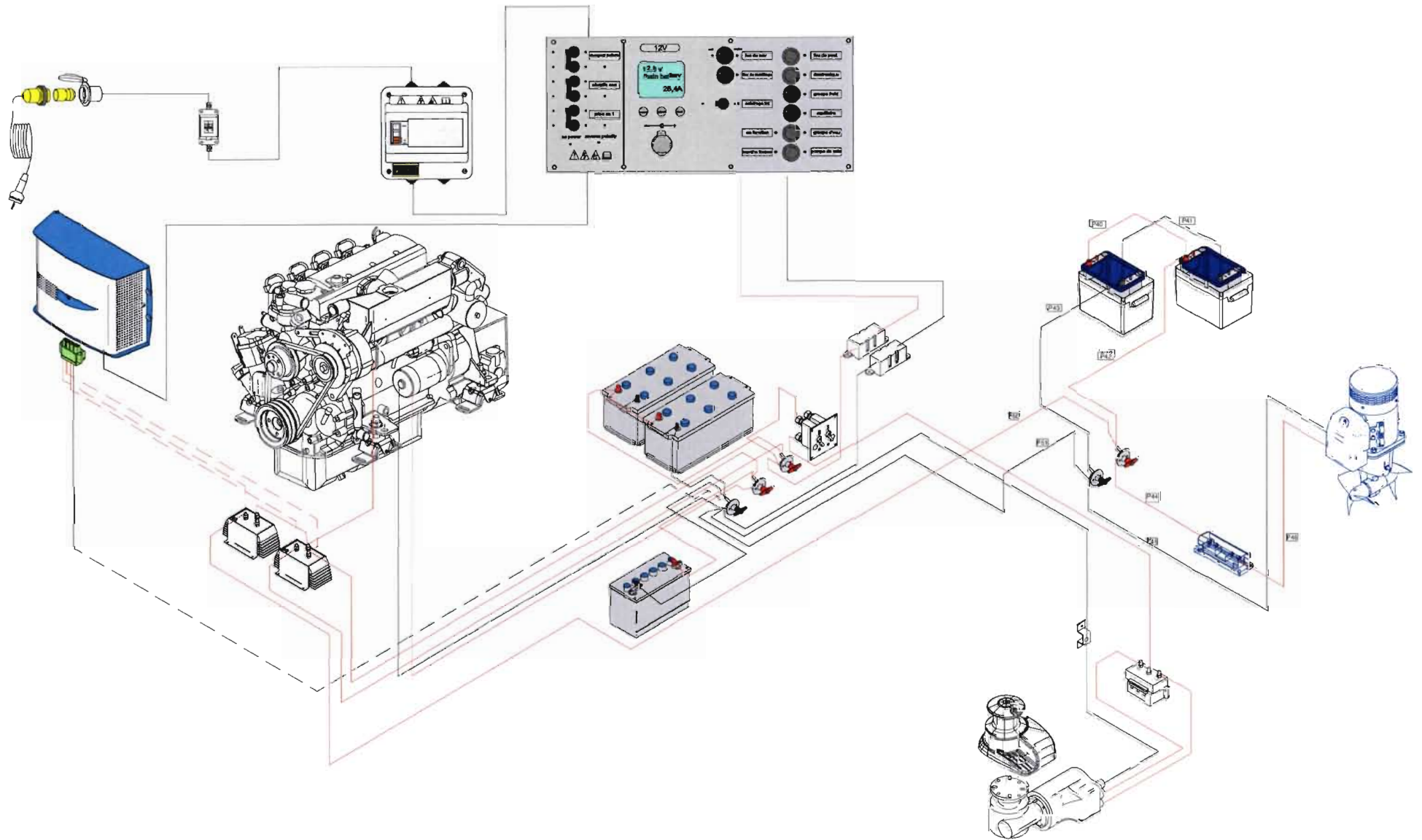



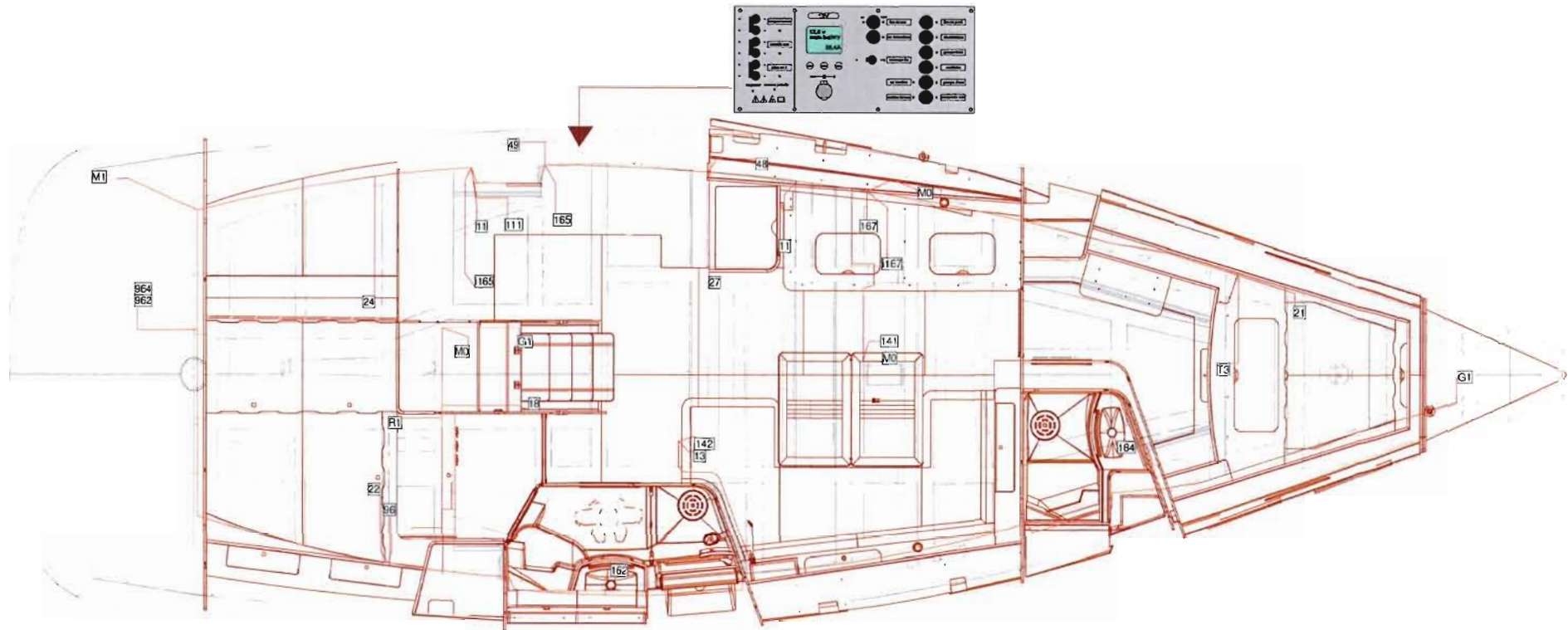



**BUNDLES INSTALLATION 12V - HULL**

**VERSION 3 CABIN**

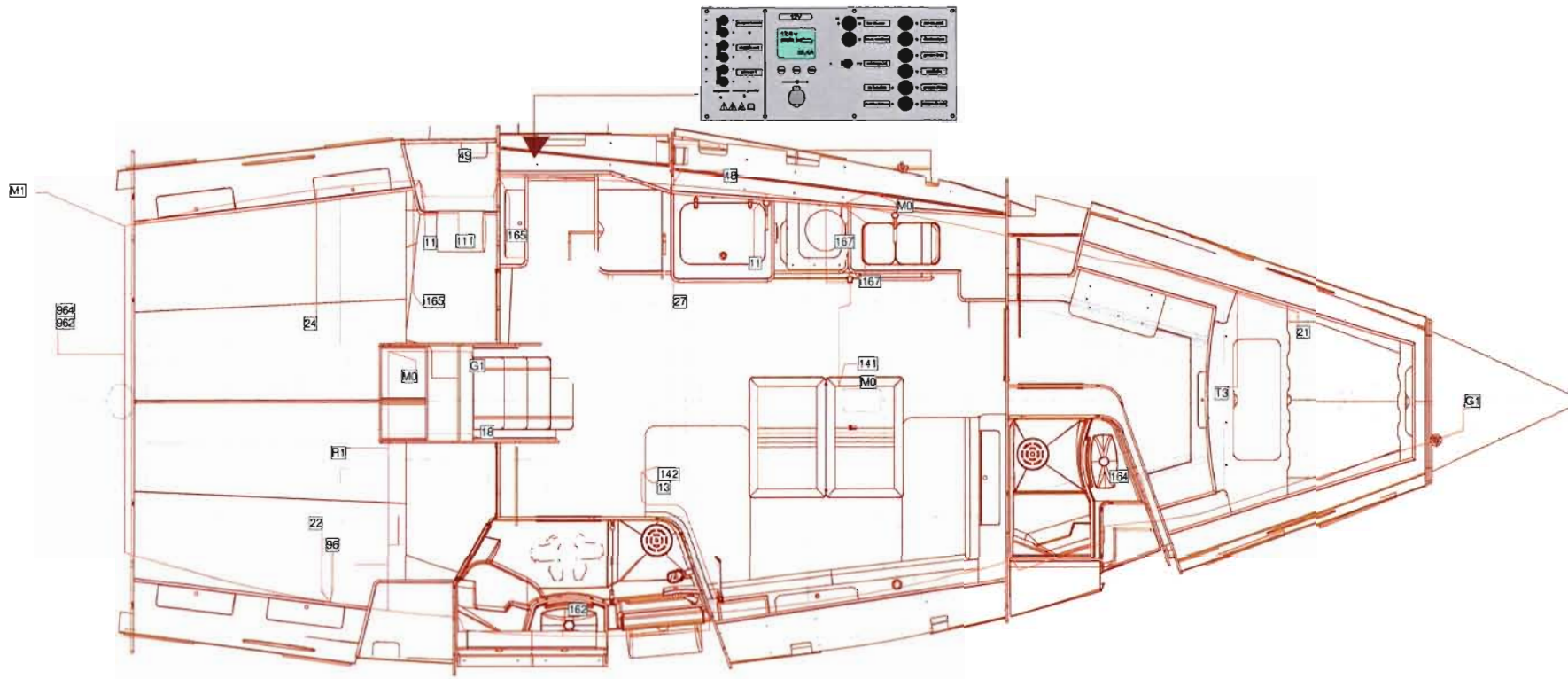

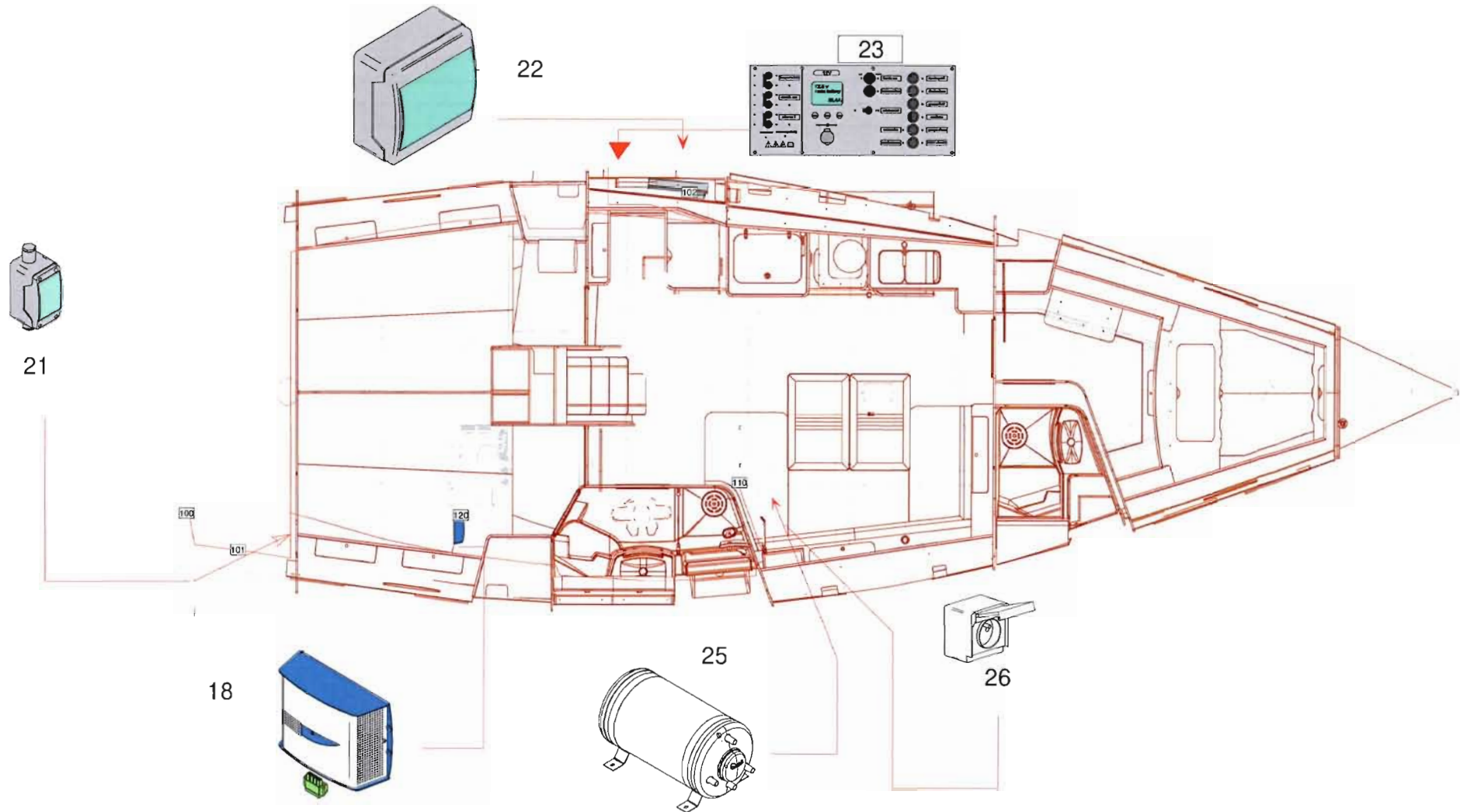

**BUNDLES INSTALLATION 220V - HULL****VERSION 3 CABIN**

<b>REFERENCE ON DIAGRAM</b>	<b>FUNCTIONS</b>
18	Battery charger 25A / 40A
21	Breaker 220V
22	Differential circuit breaker
23	Electrical panel
25	Water heater 220V
26	Socket for water heater 220V

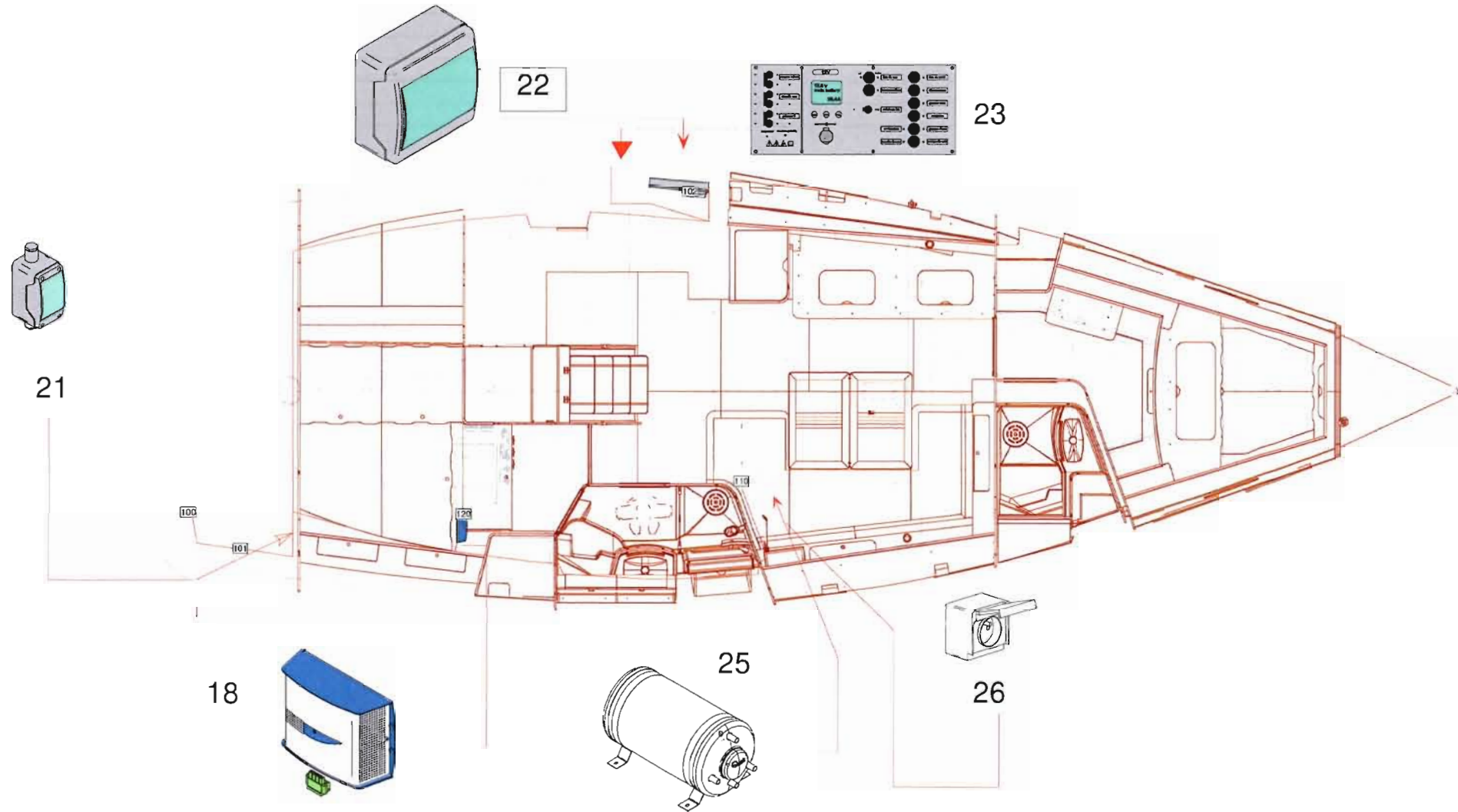

**BUNDLES INSTALLATION 220V - HULL****VERSION 2 CABIN**

REFERENCE ON DIAGRAM	FUNCTIONS
18	Battery charger 25A / 40A
21	Breaker 220V
22	Differential circuit breaker
23	Electrical panel
25	Water heater 220V
26	Socket for water heater 220V







